



This publication contains the installation, operation and maintenance instructions for the *Automatic Belt Tensioner*.



**Carefully read this publication and any supplemental documents prior to any installation or maintenance procedure.**

Loren Cook brochure, *Automatic Belt Tensioner*, provide additional information describing the equipment, fan performance, available accessories and specification data.

For additional safety information, refer to AMCA Publication 410-96, *Safety Practices for Users and Installers of Industrial and Commercial Fans*.

All of the publications listed above can be obtained from:

- [lorencook.com](http://lorencook.com)
- [info@lorencook.com](mailto:info@lorencook.com)
- 417-869-6474 ext. 166

For information and instructions on special equipment, contact Loren Cook Company at 417-869-6474. The Automatic Belt Tensioner uses sealed bearings which do not require maintenance and contain no user-serviceable parts. Do not disassemble the belt tensioner.

### BELT TENSIONER IDENTIFICATION DETAIL

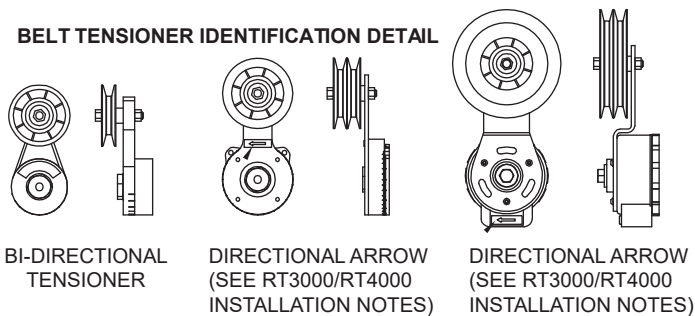

**RT1000 WITH 1 GROOVE "A" BELT IDLER**

**RT3000 WITH 2 GROOVE "A" BELT IDLER**

**RT4000 WITH 2 GROOVE "B" BELT IDLER**

## Belt Tensioner Installation instructions

1. Set belt tensioner assembly on outer surface of the outboard bearing support and line up with hole. Bring a 3/8-16 X 1-1/4 bolt through the hole and thread it into the bottom of the tensioner.
2. Tighten the bolt finger tight, allowing tensioner assembly to rotate freely.
3. Install belt around all sheaves and rotate tensioner counterclockwise (clockwise for clockwise units) until belt feels tight and you feel light spring tension.
4. While holding tensioner at this position, use a marking pencil to make an alignment mark on the tensioner and the outboard bearing support so that the tensioner can be rotated back to the mark after removing the belt.
5. Remove the belt and realign the marks on the tensioner. Now rotate the belt tensioner assembly counterclockwise (clockwise for clockwise units) until the alignment marks are spaced approximately 1/2 to 3/4 apart.

6. Tighten mounting bolt fully and install belt by wrapping it around tensioner idler pulley, use palm of hand and rotate tensioner arm clockwise (counterclockwise for clockwise units) until there is enough slack in the belt to allow it to slip over the driver pulley and then the driven pulley. If using RT4000 tensioner and spring force is too much to rotate tensioner arm enough to install belts by hand, use procedure given in note 9 and 10 below.

7. Check belt tension by pushing on the belt on the tension side. Note that the tensioner will move in as more force is applied by pushing on the belt. Hold the end of the belt tensioner arm stationary with firm hand pressure and push on the belt again. If the tension feels right and the tensioner arm doesn't move with an equal amount of force applied, then the tension should be correct. If there is any doubt that the tension is correct, check it by starting the fan and listening for belt squeal. If excessive belt squeal is heard- loosen tensioner mounting bolt, and rotate tensioner counterclockwise an additional 1/2", and repeat steps 6 and 7.



**Caution: Do not use the top assembly nut to add additional tension as this may potentially damage the tensioner. It must be re-positioned per tensioning assembly instructions.**

## RT3000/RT4000 Installation Notes:

8. The RT3000 and RT4000 have a directional arrow to ensure proper installation. The arrow must always point toward the belt being tensioned. In this application, units with counterclockwise rotation point to the right and clockwise rotation to the left. If arrow is pointing the wrong direction. Remove the back of tensioner housing and the spring. Then flip the spring over. The spring's center "tail" must engage the slot in the center shaft. Then push out the directional arrow piece located in the arm assembly, and reverse the arrow so it points the opposite way and snap in place. Note that if the arrow piece is not pointing in the correct location the tensioner cannot be reassembled.

9. The RT4000 tensioner requires considerable force to overcome it's spring tension. If force is so strong that procedure given in note 7 won't work, use the following procedure. With tensioner mounting bolt only finger tight, rotate tensioner back so that belts can be installed easily now rotate tensioner arm until belts begin to tighten and you feel light spring tension. Hook in provided spanner wrench and rotate Tensioner arm until alignment marks are 3/4 apart. While holding spanner wrench securely at at this position, tighten tensioner mounting bolt fully and remove spanner wrench.

10. Once installed, the RT4000 Tensioner has Considerable Force. The Tensioner comes with a limited-use spanner wrench. The spanner wrench must be used to hold the tensioner base when loosening the mounting bolt.

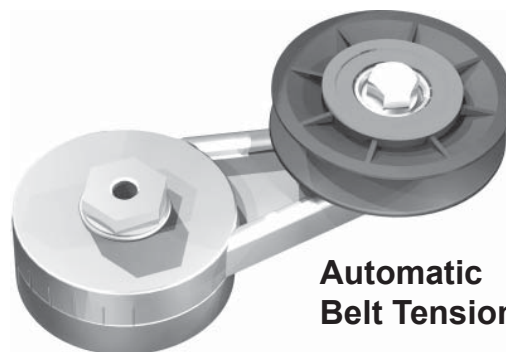

**Automatic Belt Tensioner**

### Belt Tensioner Maintenance Notes;

The belt tensioner idler pulley bearings are electric motor quality permanently lubricated ball bearings and require no maintenance. There are no parts on the tensioner that require maintenance.

### Belt tensioner Operation Notes;

The Belt tensioner will provide proper belt tension for the life of the belt. There is no need to overtension belt to compensate for belt stretch. When a new belt is needed, simply rotate tensioner clockwise and release tensioner. The belt will then be properly tensioned and aligned.

#### Clockwise Top Horizontal

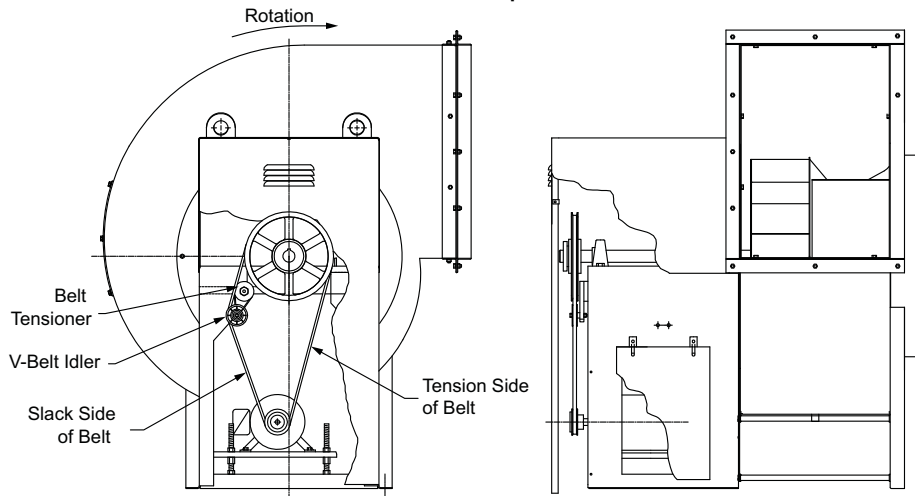

#### Counter Clockwise Top Horizontal

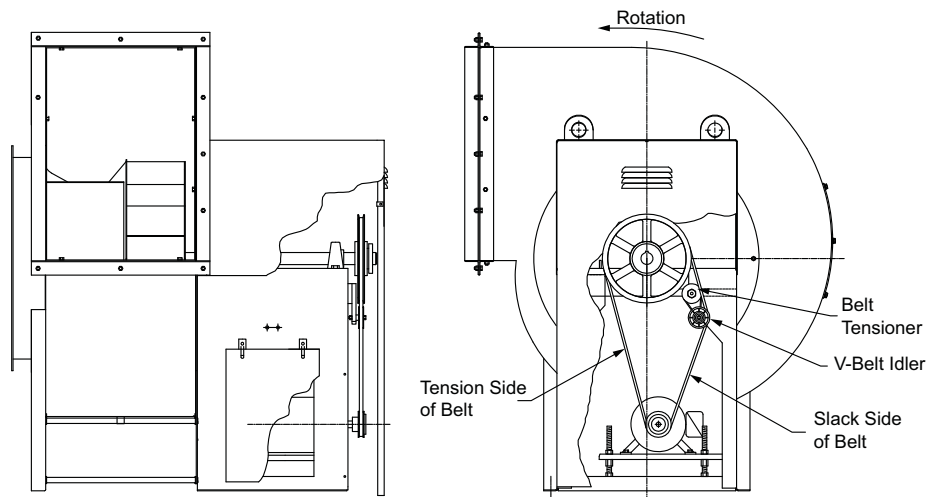

### Limited Warranty

Loren Cook Company warrants that your Loren Cook fan was manufactured free of defects in materials and workmanship, to the extent stated herein. For a period of one (1) year after date of shipment, we will replace any parts found to be defective without charge, except for shipping costs which will be paid by you. This warranty is granted only to the original purchaser placing the fan in service. This warranty is void if the fan or any part thereof has been altered or modified from its original design or has been abused, misused, damaged or is in worn condition or if the fan has been used other than for the uses described in the company manual. This warranty does not cover defects resulting from normal wear and tear. To make a warranty claim, notify Loren Cook Company, General Offices, 2015 East Dale Street, Springfield, Missouri 65803-4637, explaining in writing, in detail, your complaint and referring to the specific model and serial numbers of your fan. Upon receipt by Loren Cook Company of your written complaint, you will be notified, within thirty (30) days of our receipt of your complaint, in writing, as to the manner in which your claim will be handled. If you are entitled to warranty relief, a warranty adjustment will be completed within sixty (60) business days of the receipt of your written complaint by Loren Cook Company. This warranty gives only the original purchaser placing the fan in service specifically the right. You may have other legal rights which vary from state to state. For fans provided with motors, the motor manufacturer warrants motors for a designated period stated in the manufacturer's warranty. Warranty periods vary from manufacturer to manufacturer. Should motors furnished by Loren Cook Company prove defective during the designated period, they should be returned to the nearest authorized motor service station. Loren Cook Company will not be responsible for any removal or installation costs.



## LOREN COOK COMPANY

Corporate Offices: 2015 E. Dale St. Springfield, MO 65803  
Phone 417-869-6474 | Fax 417-862-3820 | [lorencook.com](http://lorencook.com)