



This publication contains the installation, operation and maintenance instructions for standard units of the *Gemini*: CBF- Cinder Block.



**Carefully read this publication and any supplemental documents prior to any installation or maintenance procedure.**

Loren Cook catalog, CBF, provides additional information describing the equipment, fan performance, available accessories and specification data.

For additional safety information, refer to AMCA Publication 410-96, *Safety Practices for Users and Installers of Industrial and Commercial Fans*.

All of the publications listed above can be obtained from Loren Cook Company by phoning (417) 869-6474, extension 166; by fax at (417) 832-9431; or by e-mail at [info@lorencook.com](mailto:info@lorencook.com).

For information and instructions on special equipment, contact Loren Cook Company at (417) 869-6474.

## **Receiving and Inspection**

Carefully inspect the fan and accessories for any damage and shortage immediately upon receipt of fan.

- Turn the wheel by hand to ensure it turns freely and does not bind.
- Remove shipping tape.
- Record on the *Delivery Receipt* any visible sign of damage.

## **Handling**

Lift fan by the outside housing (cabinet). Never lift by the shaft or motor.

## **Storage**

If the fan is stored for any length of time prior to installation, store it in its original shipping crate and protect it from dust, debris and the weather.

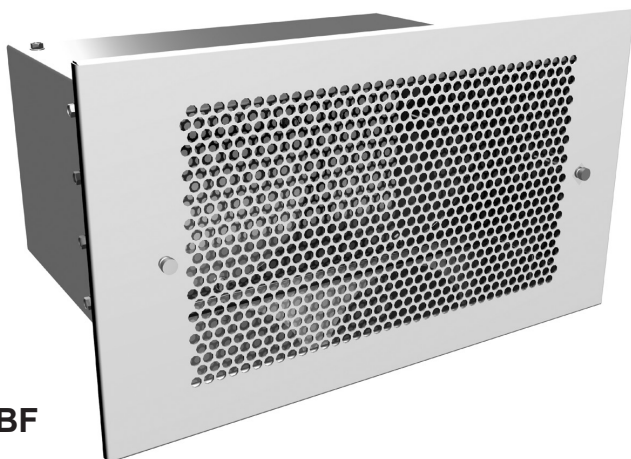

**CBF**

## **! WARNING**

### **Rotating Parts & Electrical Shock Hazard:**

Fans should be installed and serviced by qualified personnel only.

Disconnect electric power before working on unit (prior to removal of guards or entry into access doors).

Follow proper lockout/tagout procedures to ensure the unit cannot be energized while being installed or serviced.

A disconnect switch should be placed near the fan in order that the power can be swiftly cut off, in case of an emergency and in order that maintenance personnel are provided complete control of the power source.

Grounding is required. All field-installed wiring must be completed by qualified personnel. All field installed wiring must comply with National Electric Code (NFPA 70) and all applicable local codes.

Fans and blowers create pressure at the discharge and vacuum at the inlet. This may cause objects to get pulled into the unit and objects to be propelled rapidly from the discharge. The discharge should always be directed in a safe direction and inlets should not be left unguarded. Any object pulled into the inlet will become a projectile capable of causing serious injury or death.

When air is allowed to move through a non-powered fan, the impeller can rotate, which is referred to as windmilling. Windmilling will cause hazardous conditions due to unexpected rotation of components. Impellers should be blocked in position or air passages blocked to prevent draft when working on fans.

Friction and power loss inside rotating components will cause them to be a potential burn hazard. All components should be approached with caution and/or allowed to cool before contacting them for maintenance.

Under certain lighting conditions, rotating components may appear stationary. Components should be verified to be stationary in a safe manner, before they come into contact with personnel, tools or clothing.

Failure to follow these instructions could result in death or serious injury.

***Follow the wiring diagram in the disconnect switch and the wiring diagram provided with the motor. Correctly label the circuit on the main power box and always identify a closed switch to promote safety (i.e., red tape over a closed switch).***

## Installation

CBF units are intended to replace an 8"x16" standard cinder block in a block wall. Slide unit into open block location, as desired, and screw into place using pre-punched holes in the front flange. After unit is installed and wired, attach grille using the two screws provided.

## Wiring Installation

All wiring should be in accordance with local ordinances and the National Electrical Code, NFPA 70. Ensure the power supply (voltage, frequency, and current carrying capacity of wires) is in accordance with the motor nameplate.

**Lock off all power sources before unit is wired to power source.**

## Final Installation Steps

1. Inspect fasteners and setscrews, particularly fan mounting fasteners, and tighten.
2. Inspect for correct amperage and voltage with an ammeter and voltmeter.
3. Ensure all accessories are installed.
4. Make sure wheel does not rub against the inlet.

## Operation

### Pre-Start Checks:

1. Lock out all the primary and secondary power sources.
2. Inspect fasteners and setscrews, particularly those used for mounting the fan, and tighten if necessary.
3. Inspect motor wiring.
4. Ensure fan and duct work are clean and free of debris.
5. Restore power to unit.

## Inspection

Inspection of the fan should be conducted at the first 30 minute interval of satisfactory operation. During the inspection, stop the fan and inspect as per directions below.

### 30 Minute Interval

Inspect bolts, setscrews, and motor mounting bolts. Adjust and tighten as necessary.

## Grille Installation

Attach the grille by hand-tightening the knurled screws. When the unit is furnished with a filter, place the knurled screws through the hole in the grille. Install the filter through the holes provided in the filter frame.

## Maintenance

Establish a schedule for inspecting all parts of the fan. The frequency of inspection depends on the operating conditions and location of the fan.

1. Turn off all power going to Cinder Block Fan.
2. Remove (2) grille screws with Phillips Head screwdriver.
3. Unfasten (4) blower panel screws from support angles.
4. Pull blower assembly out approximately 12 inches.
5. Reach inside housing and unplug receptacle from junction box.

## CBF Parts List

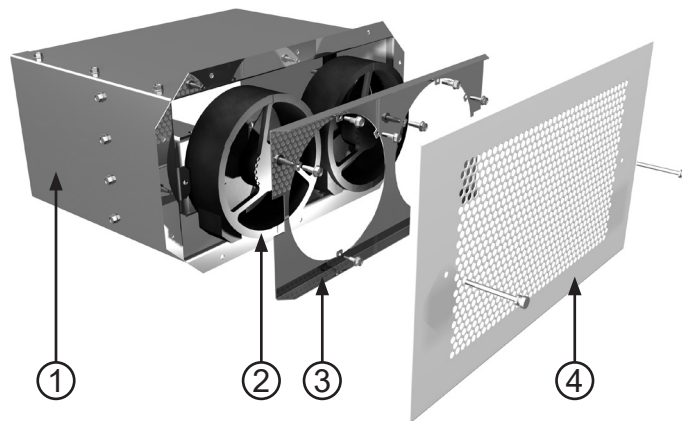

Part No.	CBF
1	Housing
2	Blower Assembly
3	Blower Mounting Plate
4	Grille

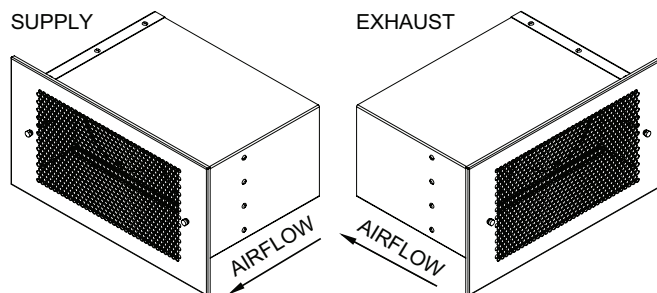

## Limited Warranty

Loren Cook Company warrants that your Loren Cook fan was manufactured free of defects in materials and workmanship, to the extent stated herein. For a period of one (1) year after date of shipment, we will replace any parts found to be defective without charge, except for shipping costs which will be paid by you. This warranty is granted only to the original purchaser placing the fan in service. This warranty is void if the fan or any part thereof has been altered or modified from its original design or has been abused, misused, damaged or is in worn condition or if the fan has been used other than for the uses described in the company manual. This warranty does not cover defects resulting from normal wear and tear. To make a warranty claim, notify Loren Cook Company, General Offices, 2015 East Dale Street, Springfield, Missouri 65803-4637, explaining in writing, in detail, your complaint and referring to the specific model and serial numbers of your fan. Upon receipt by Loren Cook Company of your written complaint, you will be notified, within thirty (30) days of our receipt of your complaint, in writing, as to the manner in which your claim will be handled. If you are entitled to warranty relief, a warranty adjustment will be completed within sixty (60) business days of the receipt of your written complaint by Loren Cook Company. This warranty gives only the original purchaser placing the fan in service specifically the right. You may have other legal rights which vary from state to state.



## LOREN COOK COMPANY

Corporate Offices: 2015 E. Dale St. Springfield, MO 65803  
Phone 417-869-6474 | Fax 417-862-3820 | [lorencook.com](http://lorencook.com)