

This publication contains the installation, operation and maintenance instructions for standard units of the *FCP: Fiberglass Blowers*.



Carefully read this publication and any supplemental documents prior to any installation or maintenance procedure.

Loren Cook catalog, *Fiberglass*, provides additional information describing the equipment, fan performance, available accessories and specification data.

For additional safety information, refer to AMCA Publication 410-96, *Safety Practices for Users and Installers of Industrial and Commercial Fans*.

All of the publications listed above can be obtained from:

- lorencook.com
- info@lorencook.com
- 417-869-6474 ext. 166

For information and instructions on special equipment, contact Loren Cook Company at 417-869-6474.

Receiving and Inspection

Carefully inspect the fan and accessories for any damage and shortage immediately upon receipt of the fan.

- Turn the wheel by hand to ensure it turns freely and does not bind.
- Check dampers (if supplied) for free operation of all moving parts.
- Record on the Delivery Receipt any visible sign of damage.

Handling

Lift the fan by the base or lifting eyes.

NOTICE! Never lift by the shaft, motor or housing.

Storage

If the fan is stored for any length of time prior to installation, completely fill the bearings with grease or moisture-inhibiting oil (refer to *Lubrication*, page 6). Rotate the wheel several revolutions every three to five days to keep a coating of grease on all internal bearing parts.

Store the fan in its original crate and protect it from dust, debris and weather.

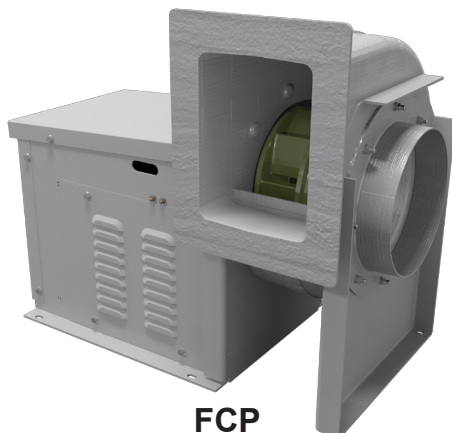

FCP

!WARNING

Rotating Parts & Electrical Shock Hazard:

Fans should be installed and serviced by qualified personnel only.

Disconnect electric power before working on unit (prior to removal of guards or entry into access doors).

Follow proper lockout/tagout procedures to ensure the unit cannot be energized while being installed or serviced.

A disconnect switch should be placed near the fan in order that the power can be swiftly cut off, in case of an emergency and in order that maintenance personnel are provided complete control of the power source.

Grounding is required. All field-installed wiring must be completed by qualified personnel. All field installed wiring must comply with National Electric Code (NFPA 70) and all applicable local codes. Ensure the power supply (voltage, frequency and current carrying capacity of wires) is in accordance with the motor nameplate.

Fans and blowers create pressure at the discharge and vacuum at the inlet. This may cause objects to get pulled into the unit and objects to be propelled rapidly from the discharge. The discharge should always be directed in a safe direction and inlets should not be left unguarded. Any object pulled into the inlet will become a projectile capable of causing serious injury or death.

When air is allowed to move through a non-powered fan, the impeller can rotate, which is referred to as windmilling. Windmilling will cause hazardous conditions due to unexpected rotation of components. Impellers should be blocked in position or air passages blocked to prevent draft when working on fans.

Friction and power loss inside rotating components will cause them to be a potential burn hazard. All components should be approached with caution and/or allowed to cool before contacting them for maintenance.

Under certain lighting conditions, rotating components may appear stationary. Components should be verified to be stationary in a safe manner, before they come into contact with personnel, tools or clothing.

Failure to follow these instructions could result in death or serious injury.

The attachment of roof mounted fans to the roof curb as well as the attachment of roof curbs to the building structure must exceed the structural requirements based on the environmental loading derived from the applicable building code for the site. The local code official may require variations from the recognized code based on local data. The licensed engineer of record will be responsible for prescribing the correct attachment based on construction materials, code requirements and environmental effects specific to the installation.

To maintain good working condition of the fan when it is stored outdoors, follow the additional instructions below.

- Coat the shaft with grease or a rust preventative compound.
- Wrap bearings for weather protection.
- Cover the inlet and outlet to prevent the accumulation of dirt and moisture in the housing.
- Periodically rotate the wheel and operate dampers (if supplied).
- Periodically inspect the unit to prevent damaging conditions.

Installation

Motor Installation

Most motors are shipped mounted on the fans with belts and drives installed. However, extremely heavy motors and drives are shipped separately. These motors and drives will require field installation.

Foundation

This fan requires a strong, level foundation of reinforced poured concrete. A correctly designed concrete foundation provides the best means for mounting floor units. The foundation's size is determined by fan size and arrangement, motor size and position, and the specific location of the installation.

Use the following guidelines to calculate foundation size:

- The overall dimensions of the foundation should extend at least six inches beyond the outline of the fan and its motor.
- The weight of the foundation should be two to three times the weight of the unit and its motor.

Isolation



NOTICE! Although a certain amount of vibration is inherent in operating centrifugal fans, extreme vibration is a serious problem that may cause structural and mechanical failure.

Isolation Base

To prevent vibration and noise from being transferred to the building, isolators are recommended. Isolators should be located between the fan system and the support structure.

Ceiling Mounted Isolators

Some applications require fan systems designed for floor mounting to be suspended from ceiling supports. In such cases, all fans should be installed on either rails or bases in the classical orientation. Typically, these systems are hung from the corners by rods, which include isolation hangers of either spring or rubber-in-shear design.

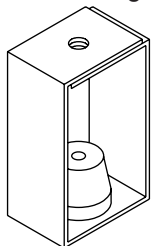
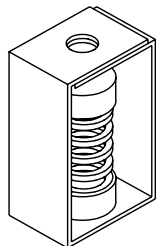

Ceiling Mounted Spring Isolator

Rubber-in-Shear Ceiling Isolator

Figure 1 - Ceiling Mount Isolators



NOTICE! Under no circumstances is the fan to be inverted and hung by its base angles!

Floor Mounted Spring Isolators

1. Mount fan and motor on isolation base (if supplied).
2. Elevate fan (or isolation base) to operating height and insert blocks to hold in position.
3. Position isolators under the fan and vertically align by inserting leveling bolt through mounting holes in the fan or the base. The isolator must be installed on a level surface.
4. Adjust the isolators by turning the leveling nut counter-clockwise several turns at a time alternately on each isolator until the fan weight is transferred onto the isolators and the fan raises uniformly off the blocks. Then remove the blocks.
5. Turn lock nut onto leveling bolt and secure firmly in place against the top of the mounting flange or frame.
6. Secure isolators to mounting surface.

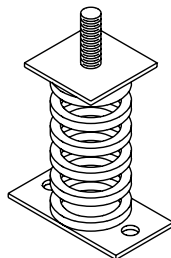

Spring Isolator

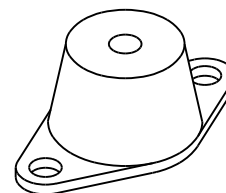

Rubber-in-Shear Isolator

Figure 2 - Floor Mount Isolators

Floor Mounted Rubber-In-Shear (RIS) Isolators

1. Mount fan and motor on an isolation base (if supplied).
2. Elevate fan to provide room to insert isolators between the base and foundation and block in position.
3. Position isolators under fan and secure bolts.
4. Remove blocks and allow fan to rest on floor. Isolators must be installed on a level surface (leveling should not be required).
5. Secure isolators to mounting surface.

Duct Installation

Efficient fan performance relies on the proper installation of inlet and discharge ducts. Be sure your fan conforms to the following guidelines.

Non-Ducted Inlet Clearance

If your fan has an open inlet (no duct work), the fan must be placed one fan wheel diameter away from walls and bulkheads.

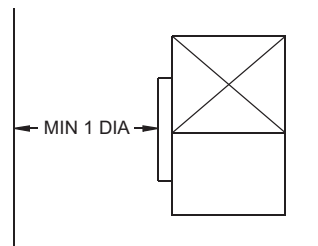

Non-Ducted Inlet Clearance

Free Discharge

Avoid a free discharge into the plenum. This will result in lost efficiency because it doesn't allow for a static regain.

Correct

Incorrect

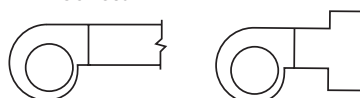

Free Discharge

Inlet Duct Turns

For ducted inlets, allow at least three fan wheel diameters between duct turns or elbows and the fan inlet.

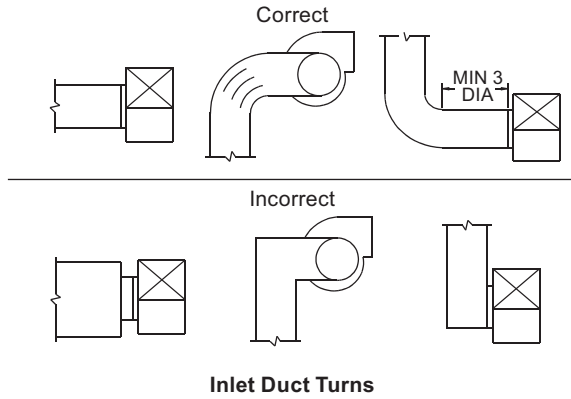

Discharge Duct Turns

Where possible, allow three duct diameters between duct turns or elbows and the fan outlet. Refer to figure above.

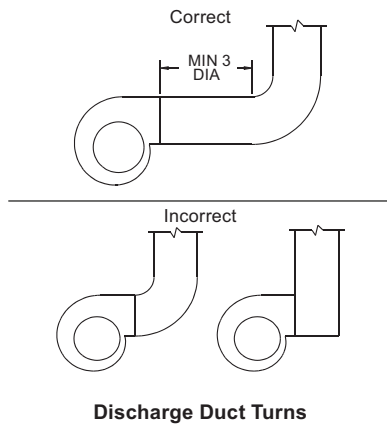

Wheel-to-Inlet Clearance

The correct wheel-to-inlet clearance is critical to proper fan performance. This clearance should be verified before initial start-up since rough handling during shipment could cause a shift in fan components. Refer to wheel/inlet drawing below for correct clearance.

Adjust the overlap by loosening the wheel hub and moving the wheel along the shaft to obtain the correct value.

A uniform radial gap (space between the edge of the cone and the edge of the inlet) is obtained by loosening the inlet cone bolts and repositioning the inlet cone.

Wheel/Inlet Clearance/Overlap

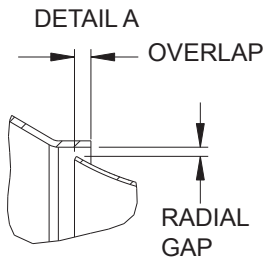

Size	Maximum Overlap
120-180	5/8"
225-270	3/4"
300-365	1"

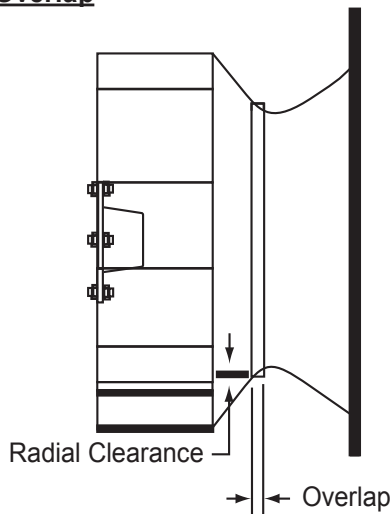

Wiring Installation

Leave enough slack in the wiring to allow for motor movement when adjusting belt tension. Some fractional motors have to be removed in order to make the connection with the terminal box at the end of the motor. To remove motor, remove bolts securing motor base to power assembly. Do not remove motor mounting bolts.

Follow the wiring diagram in the disconnect switch and the wiring diagram provided with the motor. Correctly label the circuit on the main power box and always identify a closed switch to promote safety (i.e., red tape over a closed switch).

Wheel Rotation

Test the fan to ensure the rotation of the wheel is the same as indicated by the arrow marked *Rotation*.

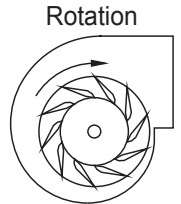

115 and 230 Single Phase Motors

Fan wheel rotation is set correctly at the factory. Changing the rotation of this type of motor should only be attempted by a qualified electrician.

208, 230 and 460 3-Phase Motors

These motors are electrically reversible by switching two of the supply leads. For this reason, the rotation of the fan cannot be restricted to one direction at the factory. See *Wiring Diagrams*, pages 5-6 for specific information on reversing wheel direction.

NOTICE! Do not allow the fan to run in the wrong direction. This will overheat the motor and cause serious damage. For 3-phase motors, if the fan is running in the wrong direction, check the control switch. It is possible to interchange two leads at this location so that the fan is operating in the correct direction.

Belt and Pulley Installation

Belt tension is determined by the sound the belts make when the fan is first started. The belts will produce a loud squeal, which dissipates after the fan is operating at full capacity. If belt tension is too tight or too loose, lost efficiency and damage can occur.

Do not change the pulley pitch diameter to change tension. The change will result in a different fan speed than desired.

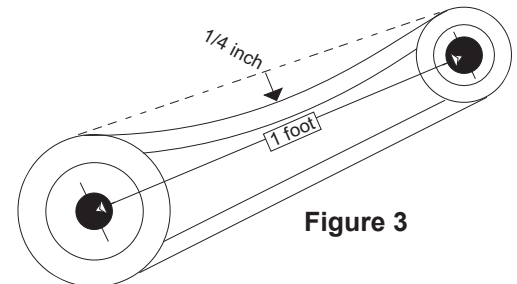

Figure 3

1. Loosen motor plate adjustment nuts on L-bolts and move motor plate in order that the belts can easily slip into the grooves on the pulleys. Never pry, roll or force the belts over the rim of the pulley.
2. Slide motor plate back until proper tension is reached. For proper tension, a deflection of approximately 1/4" per foot of center distance should be obtained by firmly pressing the belt. Refer to *Figure 3*.

- Lock the motor plate adjustment nuts in place.
- Ensure pulleys are properly aligned. Refer to *Figure 4*.

Tolerance

Center Distance	Max. Gap
Up through 12"	1/16"
12" up through 48"	1/8"
Over 48"	1/4"

Figure 4

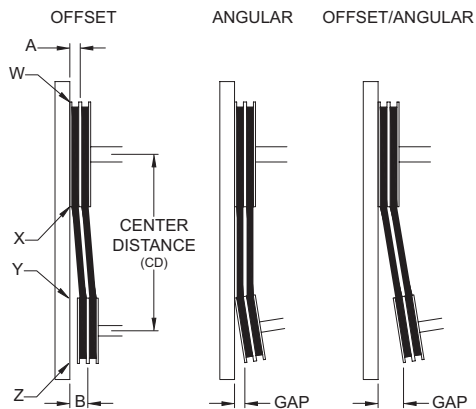

Pulley Alignment

Pulley alignment is adjusted by loosening the motor pulley setscrew and by moving the motor pulley on the motor shaft.

Figure 4 indicates where to measure the allowable gap for the drive alignment tolerance. All contact points (indicated by WXYZ) are to have a gap less than the tolerance shown in the table. When the pulleys are not the same width, the allowable gap must be adjusted by half of the difference in width (as shown in A & B of *Figure 4*). *Figure 5* illustrates using a carpenter's square to adjust the position of the motor pulley until the belt is parallel to the longer leg of the square.

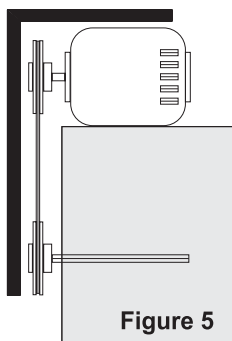

Final Installation Steps

- Inspect fasteners and setscrews, particularly fan mounting and bearing fasteners and tighten according to the recommended torque shown in the table below.
- Inspect for correct voltage with a voltmeter.
- Ensure all accessories are installed

Recommended Torque for Setscrews/Bolts (IN-LB)

Size	Key Hex Across Flats	Recommended Torque		Size	Recommended Torque
		Min.	Max.		
#8	5/64"	15	21	3/8"-16	324
#10	3/32"	27	33	1/2"-13	780
1/4	1/8"	70	80	5/8"-11	1440
5/16	5/32"	140	160	3/4"-10	2400
3/8	3/16"	250	290	7/8"-9	1920
7/16	7/32"	355	405	1"-8	2700
1/2	1/4"	560	640	1-1/8"-7	4200
5/8	5/16"	1120	1280	1-1/4"-7	6000
3/4	3/8"	1680	1920	-	-
7/8	1/2"	4200	4800	-	-
1	9/16"	5600	6400	-	-

Recommended Torque for Setscrews/Bolts on FRP (FT-LB)

Size (inches)	18-8 SST Hardware Torque
No. 10	7
1/4"	12
5/16"	20
3/8"	30
7/16"	41
1/2"	54
5/8"	86
3/4"	128

Operation

Pre-Start Checks

- Lock out all the primary and secondary power sources.
- Inspect and tighten fasteners and setscrews, particularly fan mounting fasteners.
- Inspect belt tension and pulley alignment.
- Inspect motor wiring.
- Ensure belt touches only the pulleys.
- Ensure fan and ductwork are clean and free of debris.
- Inspect wheel-to-inlet clearance. The correct wheel-to-inlet clearance is critical to proper fan performance.
- Close and secure all access doors.
- Restore power to fan.

Start-Up

Turn on the fan. In variable speed units, set the fan to its lowest speed. Inspect for the following:

- Direction of rotation
- Excessive vibration
- Unusual noise
- Bearing noise
- Improper belt alignment or tension (listen for squealing)
- Improper motor amperage or voltage



NOTICE! If a problem is discovered, immediately shut the fan off. Lock out all electrical power and check for the cause of the trouble. Refer to *Troubleshooting* on page 7.

Use of Variable Frequency Drives

Motors

Motors that are to be operated using a Variable Frequency Drive (VFD) must be VFD Compatible. At a minimum, this must be a Premium Efficiency motor with Class F insulation. Motors that are not supplied by Loren Cook Company should have the recommendation of the motor manufacturer for use with a VFD.

Grounding

The fan frame, motor and VFD must be connected to a common earth ground to prevent transient voltages from damaging rotating elements.

Wiring

Line reactors may be required to reduce over-voltage spikes in the motors. The motor manufacturer should be consulted for recommended line impedance and usage of line reactors or filters, if the lead length between the VFD and the motor exceeds 10 feet (3m).

Fan

It is the responsibility of the installing body to perform coast-down tests and identify any resonant frequencies after the equipment is fully installed. These resonant frequencies are to be removed from the operating range of the fan by using the "skip frequency" function in the VFD programming. Failure to remove resonant frequencies from the operating range will decrease the operating life of the fan and void the warranty.

Inspection

Inspection of the fan should be conducted at the first **30 minute, 8 hour and 24 hour** intervals of satisfactory operation. During the inspections, stop the fan and inspect as per the *Conditions Chart*.

30 Minute Interval

Inspect bolts, setscrews and motor mounting bolts. Adjust and tighten as necessary.

8 Hour Interval

Inspect belt alignment and tension. Adjust and tighten as necessary.

24 Hour Interval

Inspect belt tension, bolts, setscrews and motor mounting bolts. Adjust and tighten as necessary.

Maintenance

Establish a schedule for inspecting all parts of the fan. The frequency of inspection depends on the operating conditions and location of the fan.

Inspect fans exhausting corrosive or contaminated air within the first month of operation. Fans exhausting contaminated air (airborne abrasives) should be inspected every three months.

Regular inspections are recommended for fans exhausting non-contaminated air.

It is recommended the following inspections be conducted twice per year:

- Inspect bolts and setscrews for tightness. Tighten as necessary. Worn setscrews should be replaced immediately.
- Inspect belt wear and alignment. Replace worn belts with new belts and adjust alignment as needed. Refer to *Belt and Pulley Installation*, pages 3-4.
- Bearings should be inspected as recommended in the *Lubrication Conditions Chart*.
- Inspect variable inlet vanes for freedom of operation and excessive wear. The vane position should agree with the position of the control arm. As the variable inlet vanes close, the entering air should spin in the same direction as the wheel.
- Inspect springs and rubber isolators for deterioration and replace as needed.
- Inspect for cleanliness. Clean exterior surfaces only. Removing dust and grease on motor housing assures proper motor cooling. Removing dirt from the wheel and housing prevents imbalance and damage.

Wiring Diagrams

Single Speed, Single Phase Motor

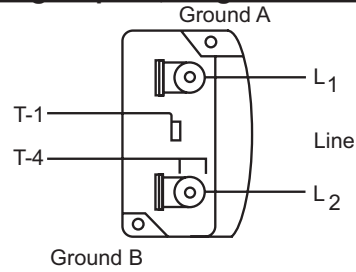

When ground is required, attach to ground A or B with No. 6 thread forming screw. To reverse, interchange T-1 and T-4.

2 Speed, 2 Winding, Single Phase Motor

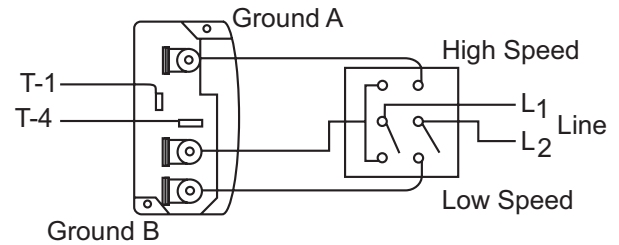

When ground is required, attach to ground A or B with No. 6 thread forming screw. To reverse, interchange T-1 and T-4 leads.

Single Speed, Single Phase, Dual Voltage

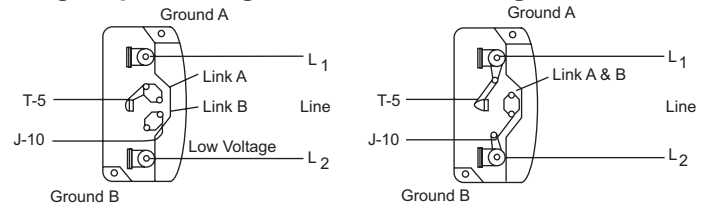

When ground is required, attach to ground A or B with No. 6 thread forming screw. To reverse, interchange T-5 and J-10 leads.

Typical Damper Motor Schematic

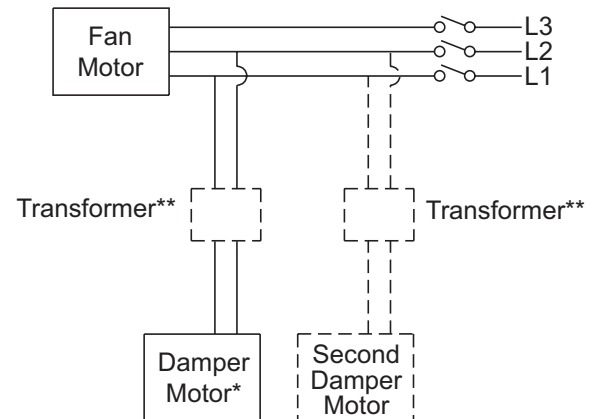

For 3-Phase, damper motor voltage should be the same between L_1 and L_2 . For single phase application, disregard L_3 .

*Damper motors may be available in 115, 230 and 460 volt models. The damper motor nameplate voltage should be verified prior to connection.

**A transformer may be provided in some installations to correct the damper motor voltage to the specified voltage.

3-Phase, 9 Lead Motor

Y-Connection

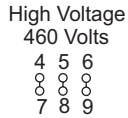
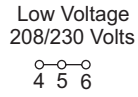

Delta-Connection

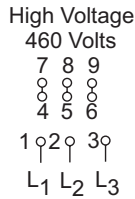
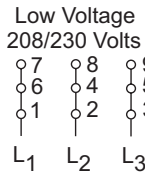

To reverse, interchange any 2 line leads.

2 Speed, 1 Winding, 3-Phase Motor

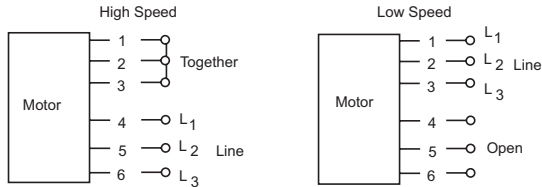

To reverse, interchange any 2 line leads. Motors require magnetic control.

2 Speed, 2 Winding, 3-Phase

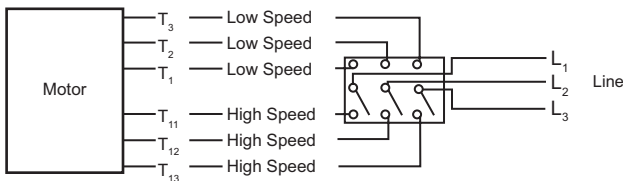

To reverse: High Speed: interchange leads T_{11} and T_{12} ; Low Speed: interchange leads T_1 and T_2 ; Both Speeds: interchange any 2 line leads.

Lubrication - Fan Bearings

Greasable fan bearings are lubricated through a grease fitting on the bearing.

Lubrication Conditions Chart

Fan Class	Fan Status	Shaft Size	Maximum Interval (operation hrs)
Centrifugal Blower Class I	Normal conditions (clean, dry & smooth)	>1-1/2"	10,000
	Extreme conditions (dirty/wet/rough)	<1-1/2"	2,000
Centrifugal Blower Class II	Normal conditions (clean, dry & smooth)	>2"	7,500
	Extreme conditions (dirty/wet/rough)	<2"	1,000
Centrifugal Blower Class III	Normal conditions (clean, dry & smooth)	>2"	3,000
	Extreme conditions (dirty/wet/rough)	<2"	500

Exceptions to the greasing interval chart:

- **Periodic Applications (any break of one week or more):** it is recommended that full lubrication be performed prior to each break in operation.
- **Higher Temperature:** it is recommended to halve the intervals for every 30°F increase in operating temperature above 120°F not to exceed 230°F for standard bearings; high temperature bearings (optional) can operate up to 400°F.
- **Vertical Shaft:** it is recommended that the intervals should be halved.

For best results, lubricate the bearing while the fan is in operation. Pump grease in slowly until a slight bead forms around the bearing seals. Excessive grease can burst seals thus reducing bearing life.

Before lubricating, the grease nipple and immediate vicinity should be thoroughly cleaned without the use of high pressure equipment. The grease should be supplied slowly as the bearing rotates, until fresh grease slips past the seal. Excessive pressure should be avoided to prevent seal damage.

In the event that the bearing cannot be seen, use no more than **three** injections with a hand-operated grease gun.

NOTICE! Loren Cook Company uses petroleum lubricant in a lithium base. Other types of grease should not be used unless the bearings and lines have been flushed clean. If another type of grease is used, it should be a lithium-based grease conforming to NLGI grade 2 consistency. A NLGI grade 2 grease is a light viscosity, low-torque, rust-inhibiting lubricant that is water resistant. Its temperature range is from -30°F to +200°F and capable of intermittent highs of +250°F. For temperatures above 250°F, Mobiltemp SHC 32 is recommended.



Lubrication - Motor Bearings

Motors are provided with prelubricated bearings. Any lubrication instructions shown on the motor nameplate supersede instructions below.

Motor bearings without provisions for relubrication will operate up to 10 years under normal conditions with no maintenance. In severe applications, high temperatures or excessive contaminants, it is advisable to have the maintenance department disassemble and lubricate the bearings after three years of operation to prevent interruption of service.

For motors with provisions for relubrication, follow intervals of the following table.

Relubrication Intervals

Service Conditions	Nema Frame Size					
	Up to and including 184T		213T-365T		404T and Larger	
	1800 RPM and Less	Over 1800 RPM	1800 RPM and Less	Over 1800 RPM	1800 RPM and Less	Over 1800 RPM
Standard	3 yrs.	6 months	2 yrs.	6 months	1 yr.	3 months
Severe	1 yr.	3 months	1 yr.	3 months	6 months	1 month

Motors are provided with a polyurea mineral oil NGLI #2 grease. All additions to the motor bearings are to be with a compatible grease such as Exxon Mobil Polyrex EM and Chevron SRI.

The above intervals should be reduced to half for vertical shaft installations.

Motor Services

Should the motor prove defective within a one-year period, contact your local Loren Cook representative or your nearest authorized electric motor service representative.

Pulley and Belt Replacement

1. Remove pulleys from their respective shafts.
2. Clean the motor and fan shafts.
3. Clean bores of pulleys & coat the bores with heavy oil.
4. Remove grease, rust or burrs from the pulleys & shafts.
5. Remove burrs from shaft by sanding.
6. Place fan pulley on the fan shaft and the motor pulley on the motor shaft. Damage to the pulleys can occur when excessive force is used in placing the pulleys on their respective shafts.
7. Tighten in place.
8. Install belts on pulleys and align as described in *Belt and Pulley Installation*, pages 3-4.

Bearing Replacement

1. Follow all local lock-out/tag-out procedures and un-wire the unit's motor.
2. Loosen the bolts supporting the motor plate and remove the belt. Inspect the belt for signs of wear and set aside.
3. Measure and record the distance of the wheel from the housing side.
4. Using a putty knife at the wheel hub, scrape the resin from the safety plate and retaining bolt.
5. Remove the retaining bolt and safety plate & set aside.
6. Using either a jewelry screw driver or small drill bit, remove the beeswax from the set screw openings and set screw heads.
7. Remove the wheel and remove the old bearings and shaft.
8. Install the new shaft to the wheel, safety plate and retaining bolt. Tighten all per the torque values as stated on page 4.
9. Using a fiberglass resin repair kit, apply resin per the manufacture instruction over the safety plate and retaining bolt. Recommend using a Grainger part number 3RAR9 or equal.
10. Reapply beeswax to protect the set screw heads.
11. Install the new shaft by sliding the bearings to the desired location using the measurement recorded earlier and loosely mounting the bearing support. Bearing bolts and bearing set screws should be loose enough to allow shaft position later. Please note the wheel to inlet clearance matches as close as possible the diagram on page 3.
12. Tighten all hardware per the torque values as stated on page 4 and follow the *Operation Pre-Start Check* and *Start-Up* listed in this document.
13. After 24 hours of operation, retighten the setscrews to the appropriate torque. This assures full locking of the inner race to the shaft. Make sure the socket key or driver is in good condition with no rounded corners. The key should be fully engaged in the setscrew and held squarely to prevent rounding out of the setscrew socket when applying maximum torque.

Maximum Fan RPM

Size	Maximum RPM	
	FCP	FCP 66
120	4500	4500
150	3600	4300
180	2900	3600
245	2200	2700
270	2000	2400
300	1800	2200
330	1650	2000
365	1500	1800

Troubleshooting

Problem and Potential Cause

Low Capacity or Pressure:

- Incorrect direction of rotation. Make sure the fan rotates in same direction as the arrows on the motor or belt drive assembly.
- Poor fan inlet conditions. There should be a straight clear duct at the inlet.
- Improper wheel alignment.

Excessive Vibration and Noise:

- Damaged or unbalanced wheel.
- Belts too loose; worn or oily belts.
- Speed too high.
- Incorrect direction of rotation. Make sure the fan rotates in same direction as the arrows on the motor or belt drive assembly.
- Bearings need lubrication or replacement.
- Fan surge or incorrect inlet or outlet condition.

Overheated Motor:

- Motor improperly wired.
- Incorrect direction of rotation. Make sure the fan rotates in same direction as the arrows on the motor or belt drive assembly.
- Cooling air diverted or blocked.
- Improper inlet clearance.
- Incorrect fan RPMs.
- Incorrect voltage.

Overheated Bearings:

- Improper bearing lubrication
- Excessive belt tension.

Limited Warranty

Loren Cook Company warrants that your Loren Cook fan was manufactured free of defects in materials and workmanship, to the extent stated herein. For a period of one (1) year after date of shipment, we will replace any parts found to be defective without charge, except for shipping costs which will be paid by you. This warranty is granted only to the original purchaser placing the fan in service. This warranty is void if the fan or any part thereof has been altered or modified from its original design or has been abused, misused, damaged or is in worn condition or if the fan has been used other than for the uses described in the company manual. This warranty does not cover defects resulting from normal wear and tear. To make a warranty claim, notify Loren Cook Company, General Offices, 2015 East Dale Street, Springfield, Missouri 65803-4637, explaining in writing, in detail, your complaint and referring to the specific model and serial numbers of your fan. Upon receipt by Loren Cook Company of your written complaint, you will be notified, within thirty (30) days of our receipt of your complaint, in writing, as to the manner in which your claim will be handled. If you are entitled to warranty relief, a warranty adjustment will be completed within sixty (60) business days of the receipt of your written complaint by Loren Cook Company. This warranty gives only the original purchaser placing the fan in service specifically the right. You may have other legal rights which vary from state to state. For fans provided with motors, the motor manufacturer warrants motors for a designated period stated in the manufacturer's warranty. Warranty periods vary from manufacturer to manufacturer. Should motors furnished by Loren Cook Company prove defective during the designated period, they should be returned to the nearest authorized motor service station. Loren Cook Company will not be responsible for any removal or installation costs.



LOREN COOK COMPANY

Corporate Offices: 2015 E. Dale St. Springfield, MO 65803
Phone 417-869-6474 | Fax 417-862-3820 | lorencook.com