



This publication contains the installation, operation and maintenance instructions for standard units of the *GI/GR: Gravity Ventilators*.



**Carefully read this publication and any supplemental documents prior to any installation or maintenance procedure.**

Loren Cook catalog, *Gravity Ventilation*, provides additional information describing the equipment, unit performance, available accessories and specification data.

For additional safety information, refer to AMCA Publication 410-96, *Safety Practices for Users and Installers of Industrial and Commercial Fans*.

All of the publications listed above can be obtained from:

- [lorencook.com](http://lorencook.com)
- [info@lorencook.com](mailto:info@lorencook.com)
- 417-869-6474 ext. 166

For information and instructions on special equipment, contact Loren Cook Company at 417-869-6474.

### **Receiving and Inspection**

Immediately upon receipt of a GI/GR unit, carefully inspect it for damage and shortage.

- Check dampers (if supplied) for free operation of moving parts.
- Record on the Delivery Receipt any visible sign of damage.

### **Handling**

Lift the unit by the lifting lugs (refer to *Figure 4*).

**NOTICE! Never lift by the hood or end panels.**

### **Storage**

If the unit is stored for any length of time prior to installation, store it in its original shipping crate and protect it from dust, debris and the weather.

### **Installation**

#### **Standard Units**

Standard units not requiring knock down are shipped fully assembled and ready for installation.

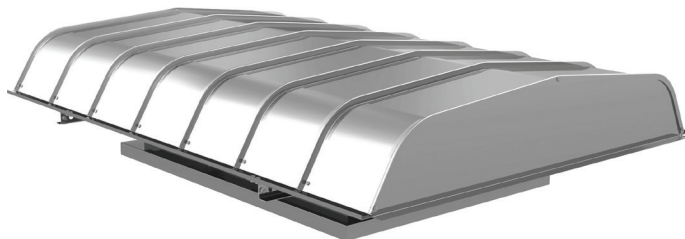

### **⚠ WARNING**

The attachment of roof mounted fans to the roof curb as well as the attachment of roof curbs to the building structure must exceed the structural requirements based on the environmental loading derived from the applicable building code for the site. The local code official may require variations from the recognized code based on local data. The licensed engineer of record will be responsible for prescribing the correct attachment based on construction materials, code requirements and environmental effects specific to the installation.

Failure to follow these instructions could result in death or serious injury.

### **Knockdown Units**

All knocked down units are factory pre-assembled and then disassembled for shipping. Reassemble by aligning holes and bolting together. Parts are marked as to allow for ease of reassembly.

Reassembling the hood is best done from the underneath side. To work on the hood it is recommended to turn the hood upside down on two wooden four by fours, this will prevent it from rocking during assembly. Attach the hood sections together by the overlapping joining seams (see *Figure 5*). Make sure the upper seam is overlapping the lower seam along their entire length. A slight tap with a rubber mallet or dead blow hammer maybe required. Align holes and use the provided section rail splice and bolts to secure the hood section(s) together (see *Figure 3*).

For units with birdscreen, first completely assemble the hood. Then fasten birdscreen securely to the inside of the section rail, (see *Figure 1*), using speed screws (A) and washer (B) stretching the birdscreen (C) as tight as possible. For units with aluminum birdscreen, the washers are replaced with 1" aluminum strips at the factory. On units with filters and birdscreen, the bird screen should extend across the throat, not hindering the filter placement (see *Figure 4*).

For units with a two piece mounting channel, insert the mounting channel splice between the two pieces of the mounting channel, aligning the holes (see *Figure 3*). Fasten the three pieces of the mounting channel assembly to the base using the bolts and nuts provided.

For units with multiple base sections: securely fasten the base sections through the base section splice brackets welded to the base sections using the bolts and nuts provided (see *Figure 3*). To eliminate the possible egress of water through the base splices, caulking is recommended.

To attach the base and hood sections: set the assembled hood on the assembled base, aligning the mounting bracket holes with the holes in the section rails. Units with support angles require the support angles to be bolted to the base, using the bolts and nuts provided.

**Figure 1**

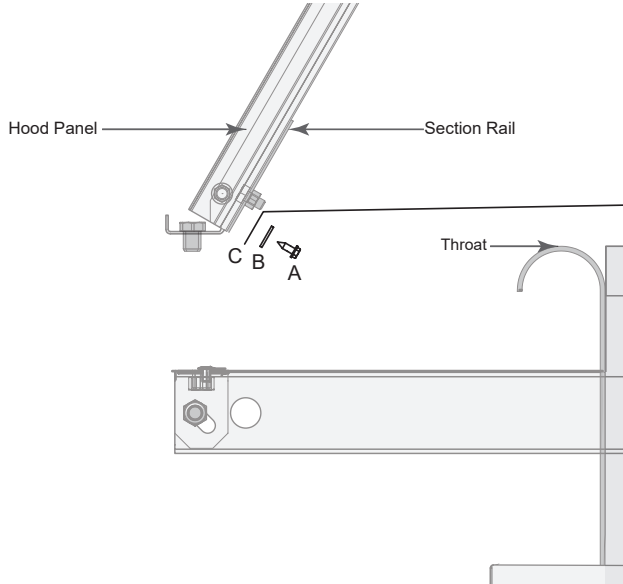

## Filters

Filters are installed between the base and the hood panels (see *Figure 4*). The filters should come in two sizes. One size fits between the end panel and the base. The other size is mounted between the base and the section rail. Filter inspection and cleaning intervals can vary from once a week to twice per year depending on contaminant present and acceptable pressure drops across the filter. Under most conditions filters may be cleaned with hot water and a mild soap solution (such as dish washing liquid) or steam. Some caustic cleaners will damage the filter. If in doubt, please consult the factory for a compatibility list. High pressure spray washers should be limited to 2,000 PSI operating pressure. Every attempt should be made to remove the contaminants from the filter in a “backwash” flow (NOTE: airflow arrow on the filter frame). Once the filter is dry, it may be returned to the appropriate filter racks in the same orientation (airflow direction) as they were removed.

## Maintenance

### Hood Access

To access the throat of the unit, take the entire hood off by removing the bolts and attaching the mounting bracket to the mounting channels (see *Figure 4*). GR units with less than a 73” throat length and GI units with less than a 61” throat length can be hinged. Hinging is accomplished by removing the bolts on one side and loosening the two bolts (refer to *Figure 2*) on the other side. Care should be taken when hinging the hood, especially in high wind conditions.

**Figure 2**

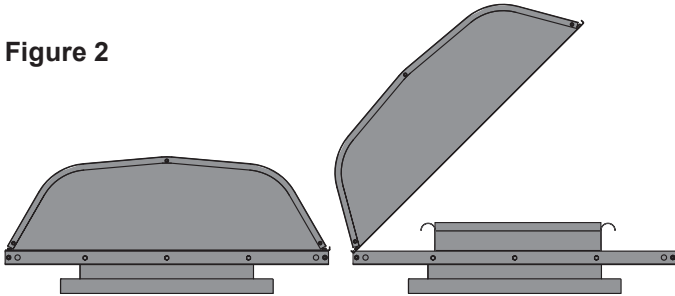

Figure 3

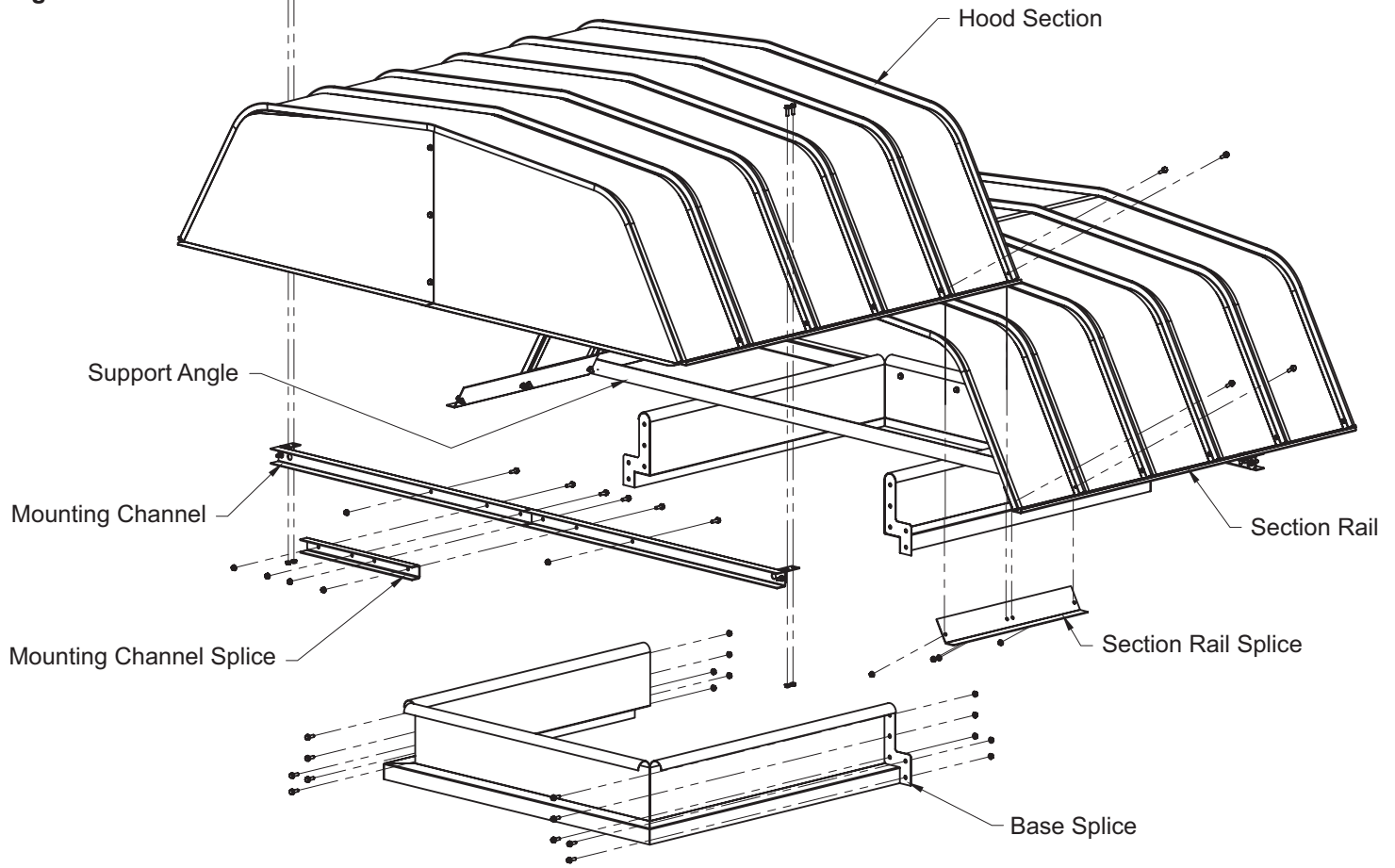
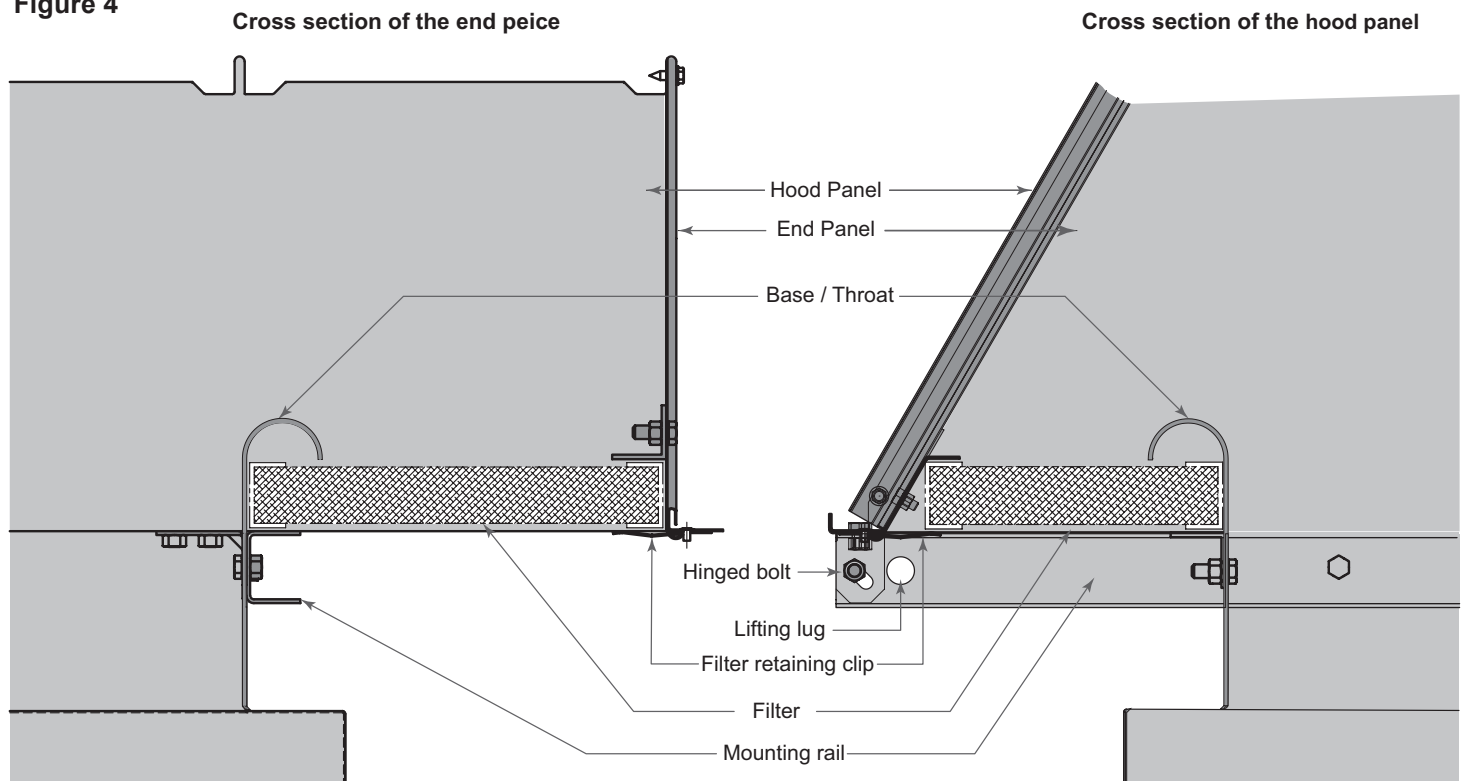

Figure 4



## Parts List

Part No.	Description	
1	Hood Panel	
2	End Panel	
3	Section Rail	
4	Mounting Bracket - Left	
5	Mounting Bracket - Right	
6	Mounting Rail	
7	Base / Throat	
8	Self-Tapping Screw	
9	Wizzbolt	
10	Wizznut	
A	Self Tapping Screw	See Figure 1, page 2
B	Flat Washer	
C	Birdscreen	

Figure 5

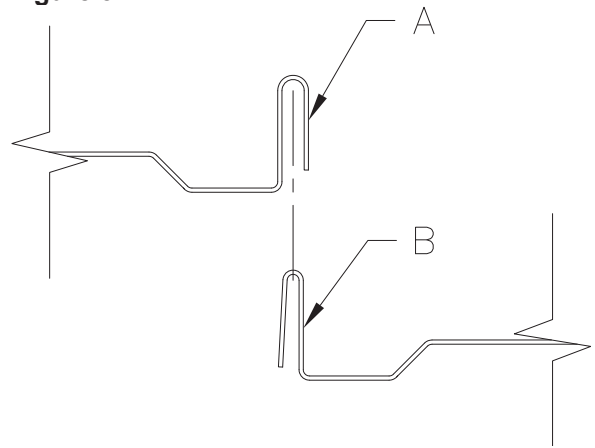

For replacement hood sections (not individual hood panels) please indicate which open end extrusion is required: (A) the top extrusion or (B) the bottom extrusion. For replacement middle hood sections the extrusion designation is not required.

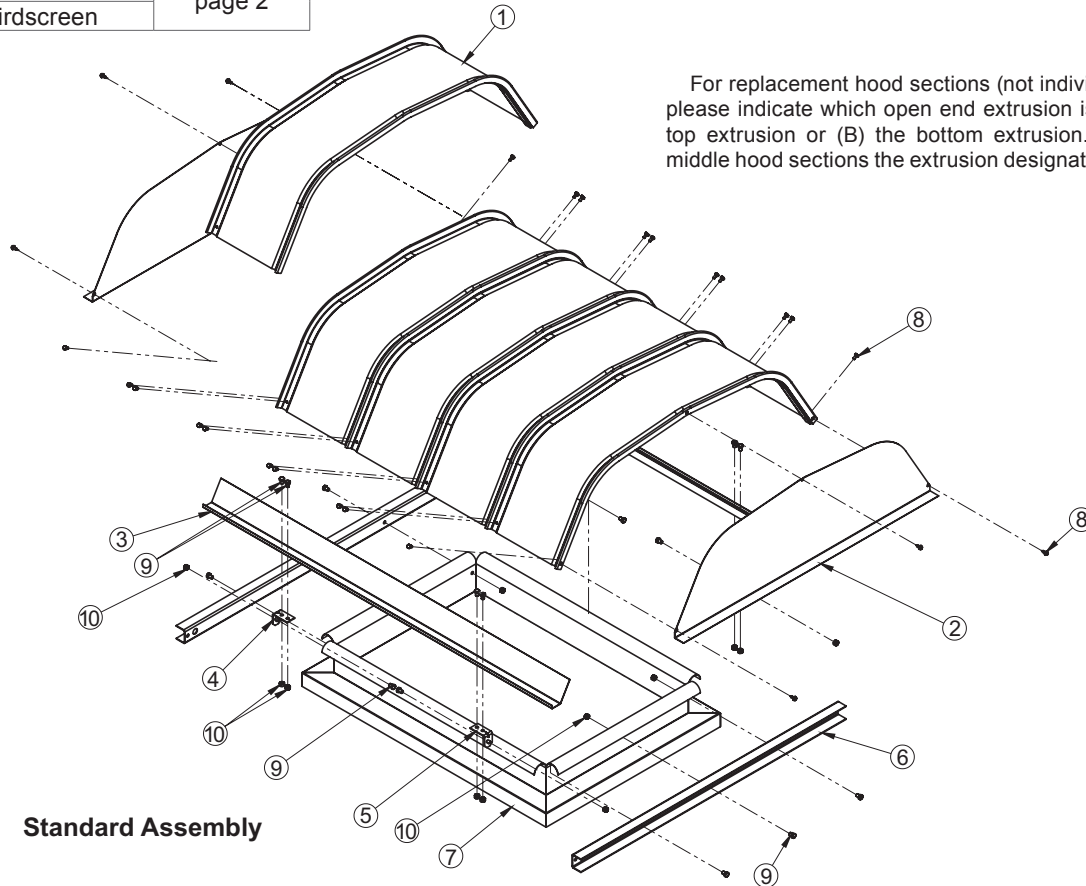

Standard Assembly

## Limited Warranty

Loren Cook Company warrants that your Loren Cook fan was manufactured free of defects in materials and workmanship, to the extent stated herein. For a period of five (5) years after date of shipment, we will replace any parts found to be defective without charge, except for shipping costs which will be paid by you. This warranty is granted only to the original purchaser placing the fan in service. This warranty is void if the fan or any part thereof has been altered or modified from its original design or has been abused, misused, damaged or is in worn condition or if the fan has been used other than for the uses described in the company manual. This warranty does not cover defects resulting from normal wear and tear. To make a warranty claim, notify Loren Cook Company, General Offices, 2015 East Dale Street, Springfield, Missouri 65803-4637, explaining in writing, in detail, your complaint and referring to the specific model and serial numbers of your fan. Upon receipt by Loren Cook Company of your written complaint, you will be notified, within thirty (30) days of our receipt of your complaint, in writing, as to the manner in which your claim will be handled. If you are entitled to warranty relief, a warranty adjustment will be completed within sixty (60) business days of the receipt of your written complaint by Loren Cook Company. This warranty gives only the original purchaser placing the fan in service specifically the right. You may have other legal rights which vary from state to state.



# LOREN COOK COMPANY

Corporate Offices: 2015 E. Dale St. Springfield, MO 65803  
Phone 417-869-6474 | Fax 417-862-3820 | [lorencook.com](http://lorencook.com)