

### INSTALLATION, OPERATION, AND MAINTENANCE MANUAL

This publication contains the installation, operation and maintenance procedures for standard units of the "LC" (HLC-D, HLC-B, TLC-D & TLC-B) Low Profile Roof Exhausters.



**Carefully read this publication and any supplemental documents prior to any installation or maintenance procedure.**

Loren Cook catalog LC provides additional information describing the equipment, fan performance, available accessories and specification data.

For additional safety information, refer to AMCA publication 410-96, *Safety Practices for Users and Installers of Industrial and Commercial Fans*.

All of the publications listed above can be obtained from Loren Cook Company by phoning (417)869-6474, extension 166; by FAX at (417)832-9431; or by e-mail at [info@lorencook.com](mailto:info@lorencook.com).

For information and instructions on special equipment, contact Loren Cook Company at (417)869-6474.

#### **!WARNING**

##### **Rotating Parts & Electrical Shock Hazard:**

Disconnect electric power before working on unit.

Follow proper lockout / tagout procedures to ensure the unit cannot be energized while being installed or serviced.

A disconnect switch should be placed near the fan in order that the power can be swiftly cut off, in case of an emergency and in order that maintenance personnel are provided complete control of the power source.

Grounding is required. All field-installed wiring must be completed by qualified personnel. All field-installed wiring must comply with National Electric Code (NFPA 70) and all applicable local codes.

Failure to follow these instructions could result in death or serious injury.

#### **Receiving and Inspection**

Carefully inspect the fan and accessories for any damage and shortage immediately upon receipt of the fan.

- Turn the wheel by hand to ensure it turns freely and does not bind.
- Check dampers (if included) for free operation of all moving parts.
- Record on the *Delivery Receipt* any visible sign of damage.

#### **Handling**

Lift the fan by the base or by the shipping carton.  
**NOTICE! Never lift by the shaft, motor or housing.**

#### **Storage**

If the fan is stored for any length of time prior to installation, store it in its original shipping crate and protect it from dust, debris and the weather.

#### **Installation**

To prevent damage to the fan during shipping, motors 5 HP and larger, and extremely heavy motors (cast iron or severe duty) are shipped loose and must be field mounted by bolting the motor on the motor mounting plate in the existing mounting slots.

#### **!WARNING**

The attachment of roof mounted fans to the roof curb as well as the attachment of roof curbs to the building structure must exceed the structural requirements based on the environmental loading derived from the applicable building code for the site. The local code official may require variations from the recognized code based on local data. The licensed engineer of record will be responsible for prescribing the correct attachment based on construction materials, code requirements and environmental effects specific to the installation.

Failure to follow these instructions could result in death or serious injury.

#### **Dampers**

If your fan is supplied with dampers, follow the directions below. If your fan does not include dampers, proceed to Belt and Pulley Installation.

- a. Place the damper inside the curb. Ensure the damper will open freely for the correct direction of the airflow.
- b. Secure to curb at the damper shelf.
- c. Drill a hole in the curb shelf for conduit needed for motor wiring.
- d. Operate the dampers manually to ensure the blades move freely. Dampers should be released from full open position to check for proper closing.
- e. Install fan over curb with the conduit location in line with the conduit hole in the curb.



HLC

## Belt and Pulley Installation

Belt tension is determined by the sound of the belts when the fan is first started. The belts will produce a loud squeal, which dissipates after the fan is operating at full capacity. If belt tension is too tight or too loose, lost efficiency and damage can occur.

Do not change the pulley pitch diameter to change tension. The change will result in a different fan speed.

## Belt and Pulley

- Loosen the motor plate adjustment bolts on motor base and move motor plate in order that the belts can easily slip into the grooves on the pulleys. Never pry, roll, or force the belts over the rim of the pulley.
- Adjust the motor plate until proper tension is reached. For proper tension, a deflection of approximately 1/4" per foot of center distance should be obtained by firmly pressing the belt. Refer to *Figure 1*.

Figure 1

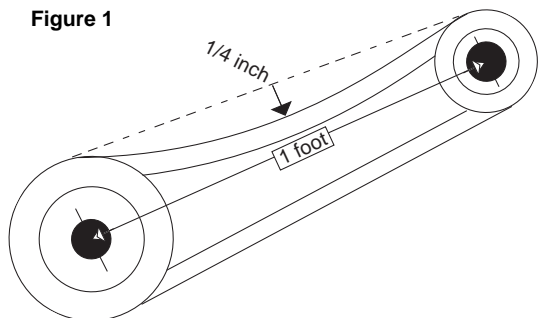

- Lock the motor plate adjustment bolts in place.
- Ensure pulleys are properly aligned. Refer to *Figure 2*.

## Pulley Alignment

Pulley alignment is adjusted by loosening the motor pulley setscrew and by moving the motor pulley on the motor shaft.

Tolerance	
Center Distance	Maximum Gap
Up thru 12"	1/16"
12" up through 48"	1/8"
Over 48"	1/4"

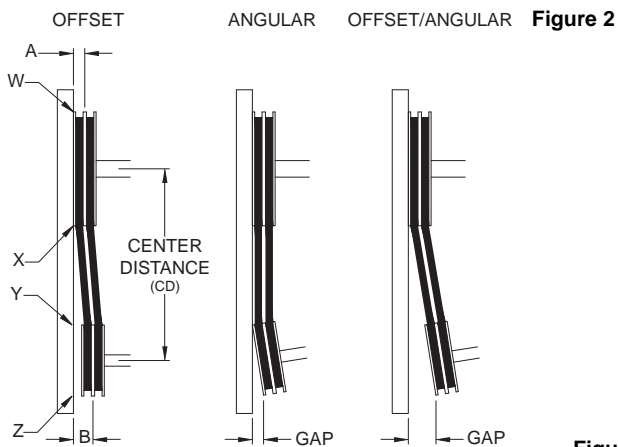

*Figure 2* indicates where to measure the allowable gap for the drive alignment tolerance. All contact points (indicated by WXYZ) are to have a gap less than the tolerance shown in the table. When the pulleys are not the same width, the allowable gap must be adjusted by half of the difference in width. *Figure 3* illustrates using a carpenter's square to adjust the position of the motor pulley until the belt is parallel to the longer leg of the square.

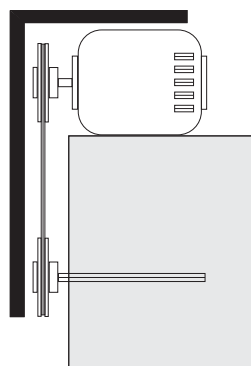

## Wiring Installation

All wiring should be in accordance with local ordinances and the National Electrical Code, NFPA 70. Ensure the power supply (voltage, frequency, and current carrying capacity of wires) is in accordance with the motor nameplate.

Refer to the *Wiring Diagrams*, next page.

Leave enough slack in the wiring to allow for motor movement when adjusting belt tension. Some fractional motors have to be removed in order to make the connection with the terminal box at the end of the motor.



**Follow the wiring diagram in the disconnect switch and the wiring diagram provided with the motor. Correctly label the circuit on the main power box and always identify a closed switch to promote safety (i.e., red tape over a closed switch).**

## Fan Installation

The fan support (roof curb) should provide a level surface for installation. If the roof is pitched more than 1/2:12, a sloped curb must be used to correct for the incline. Place fan over roof opening. Secure the fan with lag screws, anchor bolts, or other suitable fasteners.

For easier installation larger size fans may be disassembled on the ground and transported to the roof in sections. However, if the sections are not assembled properly the wheel may rub against the fan inlet causing noise.

This can be prevented by:

- Ensuring the wheel is tightly fastened on the shaft.
- Ensuring the wheel is not dropped on the shaft before the setscrews are tightened.

Should interference occur, disconnect the power source. Refer to *Bearing Replacement* on page 5.

## Final Installation Steps

- Inspect fasteners and setscrews, particularly fan mounting and bearing fasteners, and tighten according to the recommended torque shown in the table on page 4, *Recommended Torque for Setscrews/Bolts*.
- Inspect for correct amperage and voltage with an ammeter and voltmeter.
- Ensure all accessories are installed.
- Inspect wheel-to-inlet clearance on power roof fans.
- Test the fan to be sure the rotation is the same as indicated by the arrow marked **Rotation**.

**NOTICE! Do not allow the fan to run in the wrong direction. This will overheat the motor and cause serious damage. For 3-phase motors, if the fan is running in the wrong direction, check the control switch. If is possible to interchange two leads at this location so that the fan is operating in the correct direction.**

# Wiring Diagrams

## Single Speed, Single Phase Motor

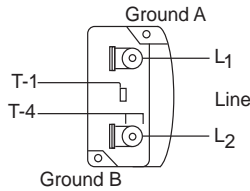

When ground is required, attach to ground A or B with no. 6 thread forming screw. To reverse, interchange T-1 and T-4.

## 2 Speed, 2 Winding, Single Phase Motor

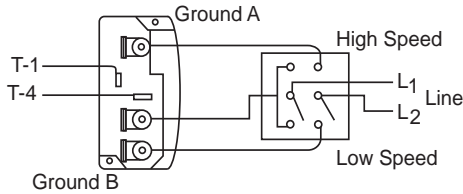

When ground required, attach to ground A or B with No. 6 thread forming screw. To reverse, interchange T-1 and T-4 leads.

## Single Speed, Single Phase, Dual Voltage

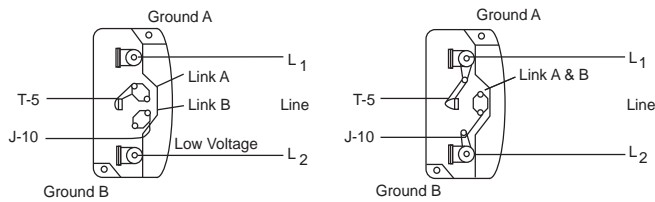

When ground required, attach to ground A or B with No. 6 thread forming screw. To reverse, interchange T-5 and J-10 leads.

## Typical Damper Motor Schematic

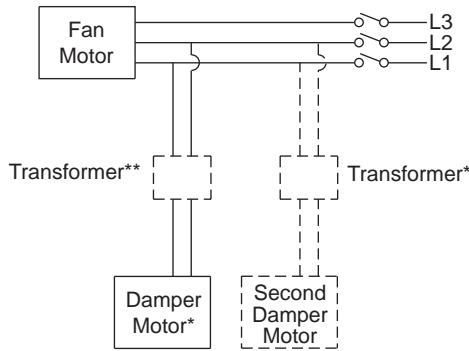

For 3 phase, damper motor voltage should be the same between L<sub>1</sub> and L<sub>2</sub>. For single phase application, disregard L<sub>3</sub>. \*Damper motors may be available in 115, 230 and 460 volt models. The damper motor nameplate voltage should be verified prior to connection. \*\*A transformer may be provided in some installations to correct the damper motor voltage to the specified voltage.

# Wiring Diagrams

## 3 Phase, 9 Lead Motor Y-Connection

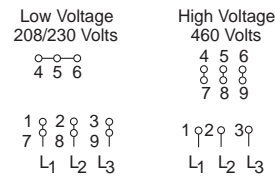

To reverse, interchange any 2 line leads.

## 3 Phase, 9 Lead Motor Delta-Connection

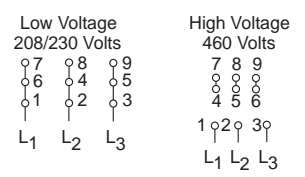

## 2 Speed, 1 Winding, 3 Phase Motor

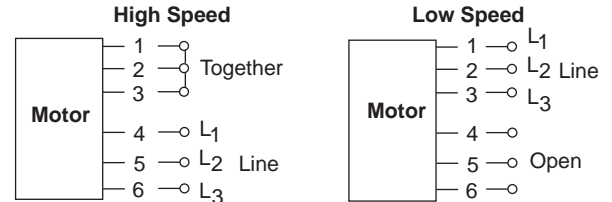

To reverse, interchange any 2 line leads. Motors require magnetic control.

## 2 Speed, 2 Winding, 3 Phase

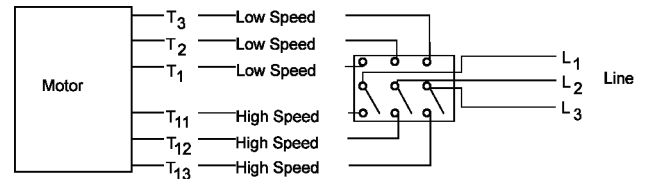

To reverse: High Speed-interchange leads T<sub>11</sub> and T<sub>12</sub>. Low Speed-interchange leads T<sub>1</sub> and T<sub>2</sub>. Both Speeds-interchange any 2 line leads.

## Operation

### Pre-Start Checks

- Lock out all the primary and secondary power sources.
- Inspect fasteners and setscrews, particularly those used for mounting the fan, and tighten if necessary.
- Inspect belt tension and pulley alignment. (Remember, if belt tension is correct, a loud squeal occurs as the fan increases to full power.)
- Inspect motor wiring.
- Ensure the belt touches only the pulleys.
- Ensure fan and ductwork are clean and free of debris.
- Test the fan to ensure the rotation of the wheel is the same as indicated by the rotation label.
- Restore power to unit.

### Recommended Torque for Setscrews/Bolts (IN/LB.)

Setscrews				Hold Down Bolts	
Size	Key Hex Across Flats	Recommended Torque Inch-lbs.			
		Min.	Max.	Size	Wrench Torque (inch-lbs)
No.10	3/32"	28	33	3/8"-16	240
1/4"	1/8"	66	80	1/2"-13	600
5/16"	5/32"	126	156	5/8"-11	1200
3/8"	3/16"	228	275	3/4"-10	2100
7/16"	7/32"	348	384	7/8"-9	2040
1/2"	1/4"	504	600	1"-8	3000
5/8"	5/16"	1104	1200	1-1/8"-7	4200
3/4"	3/8"	1440	1800	1-1/4"-7	6000

### Start Up

Turn the fan on. In variable speed units, set the fan to its lowest speed. Inspect for the following:

- Direction of rotation.
- Excessive vibration.
- Unusual noise.
- Bearing noise.
- Improper belt alignment or tension (listen for a continuous squealing noise).
- Improper motor amperage or voltage.

**NOTICE! If a problem is discovered, immediately shut off the fan. Lock out all electrical power and check for the cause of the trouble. Refer to *Troubleshooting*, page 6.**

### Inspection

Inspection of the fan should be conducted at the first **30 minute, 8 hour** and **24 hour** intervals of satisfactory operation. During the inspections, stop the fan and inspect as per the chart below.

#### 30 Minute Interval

Inspect bolts, setscrews, and motor mounting bolts. Adjust and tighten as necessary.

#### 8 Hour Interval

Inspect belt alignment and tension. Adjust and tighten as necessary.

#### 24 Hour Interval

Inspect belt tension. Adjust and tighten as necessary.

### Maintenance

Establish a schedule for inspecting all parts of the fan. The frequency of inspection depends on the operating conditions and location of the fan.

Inspect fans exhausting corrosive or contaminated air within the first month of operation. Fans exhausting contaminated air (airborne abrasives) should be inspected every three months. Clean the wheel and air inlets if material build-up is excessive. Excessive build-up can cause imbalance and failure of the wheel.

Regular inspections are recommended for fans exhausting non-contaminated air.

It is recommended the following inspections be conducted twice per year.

- Inspect bolts and setscrews for tightness. Tighten as necessary.
- Inspect belt wear and alignment. Replace worn belts with new belts and adjust alignment as needed. See *Belt and Pulley Installation*, page 1.
- Bearings should be inspected as recommended in the *Conditions Chart*.
- Inspect for cleanliness. Clean exterior surfaces only. Removing dust and grease on motor housing assures

#### Conditions Chart

RPM	Temp °F	Greasing Interval
Up to 1000	-30 to 120	6 months
	120 to 200	2 months
1000 to 3000	-30 to 120	3 months
	120 to 200	1 month
Over 3000	-30 to 120	1 month
	120 to 200	2 weeks
Any Speed	< -30	Consult Factory
Any Speed	> 200	1 week

For moist or otherwise contaminated installations; divide the interval by a factor of 3. For vertical shaft installations divide the interval by a factor of 2.

proper motor cooling.

### Fan Bearings

The fan bearings are provided prelubricated. Any specialized lubrication instructions on fan labels supersedes information provided herein. Bearing grease is a petroleum lubricant in a lithium base conforming to a NLGI #2 consistency. If user desires to utilize another type of lubricant, they take responsibility for flushing bearings and lines, and maintaining a lubricant that is compatible with the installation.

A NLGI #2 grease is a light viscosity, low-torque, rust-inhibiting lubricant that is water resistant. Its temperature range is from -30°F to 200°F and capable of intermittent highs of 250°F.

Bearings should be relubricated in accordance with the condition chart below.

For best results, lubricate the bearing while the fan is in operation. Pump grease in slowly until a slight bead forms around the bearing seals. Excessive grease can damage seal and reduce life through excess contamination and/or loss of lubricant.

In the event that the bearing cannot be seen, use no more than three injections with a hand operated grease gun.

### Motor Bearings

Motors are provided with prelubricated bearings. Any lubrication instructions shown on the motor nameplate supersede instructions below.

Direct Drive 1050/1075,1200,1300 &1500 rpm units use a prelubricated sleeve bearing that has a oil saturated wicking material surrounding it. The initial factory lubrication is adequate for up to 10 years of operation under normal conditions. However, it is advisable to add lubricant after 3 years. Use only LIGHT grade mineral oil or SAE 10W oil up to 30 drops. If the unit has been stored for a year or more it is advisable to lubricate as directed above. For direct drive units and other units in severe conditions, lubrication intervals should be reduced to half.

Motors without sleeve bearings (as described above) will have grease lubricated ball or roller bearings. Motor bearings without provisions for relubrication will operate up to 10 years under normal conditions with no maintenance. In severe applications, high temperatures or excessive contaminants, it is advisable to have the maintenance department disassemble and lubricate the bearings after 3 years of operation to prevent interruption of service.

For motors with provisions for relubrication, follow intervals of the table below.

Relubrication Intervals

Service Conditions	NEMA Frame Size					
	Up to and including 184T		213T-365T		404T and larger	
	1800 RPM and less	Over 1800 RPM	1800 RPM and less	Over 1800 RPM	1800 RPM and less	Over 1800 RPM
Standard	3 yrs.	6 months	2 yrs.	6 months	1 yr.	3 months
Severe	1 yr.	3 months	1 yr.	3 months	6 months	1 months

Motors are provided with a polyurea mineral oil NGLI #2 grease. All additions to the motor bearings are to be with a compatible grease such as Exxon Mobil Polyrex EM and Chevron SRI.

The above intervals should be reduced to half for vertical shaft installations.

### Motor Services

Should the motor prove defective within a one-year period, contact your local Loren Cook representative or your nearest authorized electric motor service representative.

### Changing Shaft Speed

All belt driven fans with motors up to and including 5HP are equipped with variable pitch pulleys. To change the fan speed, perform the following:

- Loosen setscrew on driver (motor) pulley and remove key, if equipped.
- Turn the pulley rim to open or close the groove facing. If the pulley has multiple grooves, all must be adjusted to the same width.
- After adjustment, inspect for proper belt tension.

### Speed Reduction

Open the pulley in order that the belt rides deeper in the groove (smaller pitch diameter).

### Speed Increase

Close the pulley in order that the belt rides higher in the groove (larger pitch diameter). Ensure that the RPM limits of the fan and the horsepower limits of the motor are maintained.

### Maximum RPM

TLC-B Size	Maximum RPM	
	Standard	Reinforced
100	1755	-
120	1730	-
135	1750	-
150	1640	-
165	1325	-
180	1490	-
195	1325	-
210	1275	1325
225	1135	1180
245	1015	-
270	865	-
300	830	995
330	700	880
365	610	725
402	535	610
445	455	520
490	390	430
540	345	415

HLC-B Size	Maximum RPM	
	Standard	Reinforced
100	1740	-
120	1695	-
135	1780	-
150	1620	-
165	1335	-
180	1555	-
195	1345	-
210	1245	1345
225	1140	1185
245	1010	-
270	875	-
300	825	985
330	605	865
365	615	705
402	535	615
445	445	510
490	390	430
540	345	415

### Pulley and Belt Replacement

- Clean the motor and fan shafts.
- Loosen the motor plate mounting bolts to relieve the belt tension. Remove the belt.
- Loosen the pulley setscrews and remove the pulleys from the shaft.

If excessive force is required to remove the pulleys, a three-jaw puller can be used. This tool, however, can easily warp a pulley. If the puller is used, inspect the trueness of the pulley after it is removed from the shaft. The pulley will need replacement if it is more than 0.020 inch out of true.

- Clean the bores of the pulleys and place a light coat of oil on the bores.
- Remove grease, rust and burrs from the shaft.
- Place fan pulley on the fan shaft and the motor pulley on the motor shaft. Damage to the pulleys can occur when excessive force is used in placing the pulleys on their respective shafts.
- After the pulleys have been correctly placed back onto their shafts, tighten the pulley setscrews.
- Install the belts on the pulleys. Align and adjust the belts to the proper tension as described in *Belt and Pulley Installation*, page 1.

### Bearing Replacement

The fan bearings are pillow block ball bearings.

- Loosen screws on bearing cover.
- Push bearing cover toward the wheel. As the bearing cover moves toward the wheel it will slide down to reveal the bearings and shaft.
- Remove the old bearing.
- Remove any burrs from the shaft by sanding.
- Slide new bearings onto the shaft to the desired location and loosely mount bearings onto the bearing support. Bearing bolts and setscrews should be loose enough to allow shaft positioning.
- Correctly position the wheel and tighten the bearing bolts securely to the bearing support.

- g. Align setscrews bearing to bearing and secure tightly to the shaft. **NOTICE! Never tighten both pairs of setscrews before securing bearing mounting bolts. This may damage the shaft.**
- h. Inspect the wheel position again. If necessary, readjust by loosening the bearing bolts and setscrews and repeat from step e.

### Wheel Replacement

- a. Drill two holes approximately centered between the shaft and the edge of the hub OD with the following dimensions:
- 1/4" diameter
  - 3/8" to 1/2" deep
  - 180° apart in face of hub
- b. Tap 1/4" holes to 5/16" thread with the 5/16" hole tap. Do not drill or tap any larger than recommended.
- c. Screw the puller arms into the tapped holes full depth of threads (3/8" to 1/2" approximately). Align center of puller with center of shaft. Make certain all setscrews in hub (normally a quantity of two) are fully removed. Work puller slowly to back wheel off the shaft.

### Recommended Puller

Lisle No. 45000 Sterling Wheel Puller. This puller is available at most automotive parts retail outlets.

### Wheel Replacement Components

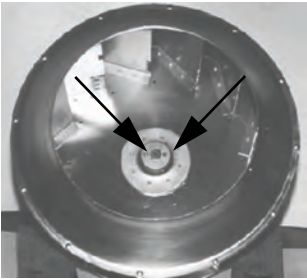

Above - Drilled hole placement.  
Right - Wheel puller.

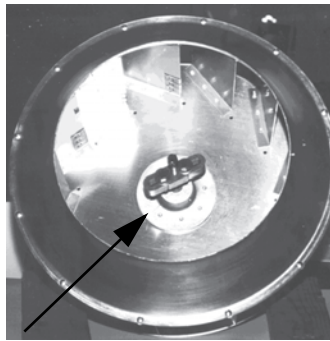

### Wheel-to-Inlet Clearance

The correct wheel-to-inlet clearance is critical to proper fan performance. This clearance should be verified before initial start-up since rough handling during shipment could cause a shift in fan components. Refer to wheel/inlet drawing for correct overlap.

Adjust the overlap by loosening the wheel hub and moving the wheel along the shaft to obtain the correct value.

A uniform radial gap (space between the edge of the cone and the edge of the inlet) is obtained by loosening the inlet cone bolts and repositioning the inlet cone.

Size	Overlap
100 - 165	3/16"
180 - 245	1/4"
270 - 300	5/16"
330 - 365	3/8"
402	7/16"
445 - 490	1/2"
540	13/16"

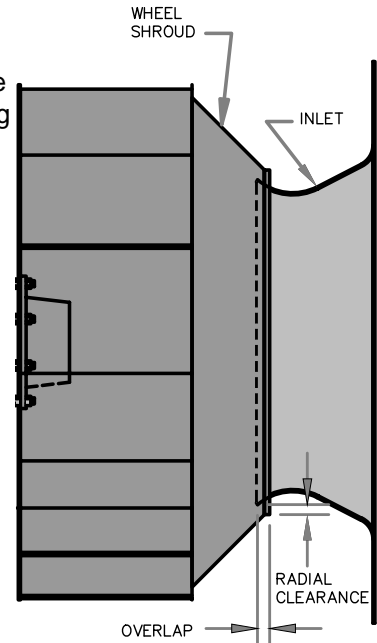

### Troubleshooting

Problem and Potential Cause
<p><b>Low Capacity or Pressure</b></p> <ul style="list-style-type: none"> <li>•Incorrect direction of rotation. Make sure the fan rotates in same direction as the arrows on the motor or belt drive assembly.</li> <li>•Poor fan inlet conditions. There should be a straight clear duct at the inlet.</li> <li>•Improper wheel alignment.</li> </ul>
<p><b>Excessive Vibration and Noise</b></p> <ul style="list-style-type: none"> <li>•Damaged or unbalanced wheel.</li> <li>•Belts too loose; worn or oily belts.</li> <li>•Speed too high.</li> <li>•Incorrect direction of rotation. Make sure the fan rotates in same direction as the arrows on the motor or belt drive assembly.</li> <li>•Bearings need lubrication or replacement.</li> <li>•Fan surge.</li> </ul>
<p><b>Overheated Motor</b></p> <ul style="list-style-type: none"> <li>•Motor improperly wired.</li> <li>•Incorrect direction of rotation. Make sure the fan rotates in same direction as the arrows on the motor or belt drive assembly.</li> <li>•Cooling air diverted or blocked.</li> <li>•Improper inlet clearance.</li> <li>•Incorrect fan RPMs.</li> <li>•Incorrect voltage.</li> </ul>
<p><b>Overheated Bearings</b></p> <ul style="list-style-type: none"> <li>•Improper bearing lubrication</li> <li>•Excessive belt tension.</li> </ul>



### HLC-D Parts List

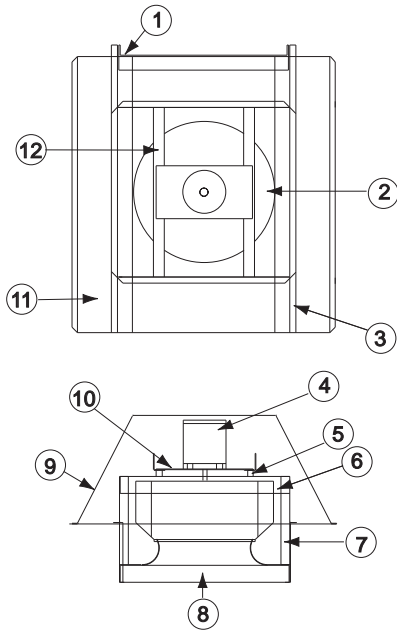

Part No.	Description	
	100-180	
1	Hinge Bar	
2	Wheel Assembly	
3	Hood Support (2)	
4	Motor	
5	Isolators (4)	
6	Mounting Rail (2)	
7	Support Posts (4)	
8	Base	
9	Hood Assembly	
10	Motor Plate	
11	Birdscreen Assembly	
12	Power Assembly Rail (2)	

### HLC-B Parts List

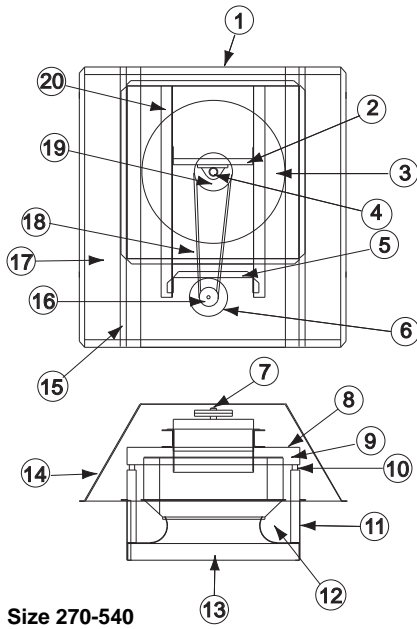

Part No.	Description	
	100-245	270-540
1	Hinge Bar	Hinge Bar
2	Bearing Plate	Bearing Plate
3	Wheel Assembly	Wheel Assembly
4	Bearings (2)	Bearings (2)
5	Motor Plate	Motor Plate
6	Motor	Motor
7	Shaft	Shaft
8	Mounting Rail (2)	Mounting Rail (2)
9	—	Isolator Brackets (4)
10	Isolators (4)	Isolators (4)
11	Support Post (4)	Support Post (4)
12	Wrapper (4)	Wrapper (4)
13	Base	Base
14	Hood Assembly	Hood Assembly
15	Hood Support (2)	Hood Support (2)
16	Driver Sheave	Driver Sheave
17	Birdscreen Assembly	Birdscreen Assembly
18	Belt Set	Belt Set
19	Driven Sheave	Driven Sheave
20	Bearings (2)	Bearings (2)

## TLC-D Parts List

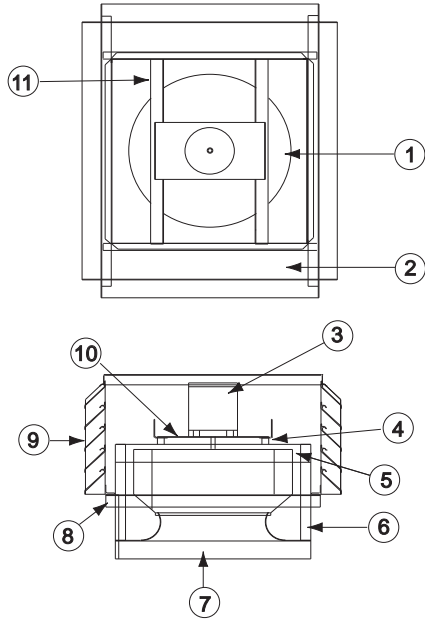

Part No.	Description	
	100-180	
1	Wheel Assembly	
2	Birdscreen Assembly	
3	Motor	
4	Isolators (4)	
5	Mounting Rails (2)	
6	Support Posts (4)	
7	Base	
8	Hood Support (2)	
9	Penthouse Assembly	
10	Motor Plate	
11	Power Assembly Rails (2)	

## TLC-B Parts List

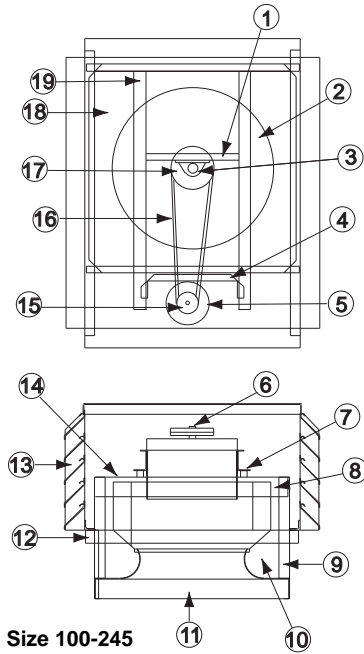

Part No.	Description	
	100-245	270-540
1	Bearing Plate	Bearing Plate
2	Wheel Assembly	Wheel Assembly
3	Bearings (2)	Bearings (2)
4	Motor Plate	Motor Plate
5	Motor	Motor
6	Shaft	Shaft
7	Isolators (4)	Isolators (4)
8	—	Isolator Brackets (4)
9	Support Posts (4)	Support Posts (4)
10	Wrapper (4)	Wrapper (4)
11	Base	Base
12	Hood Support (2)	Hood Support (2)
13	Penthouse Assembly	Penthouse Assembly
14	Mounting Rail (2)	Mounting Rail (2)
15	Driver Sheave	Driver Sheave
16	Belt Set	Belt Set
17	Driven Sheave	Driven Sheave
18	Birdscreen Assembly	Birdscreen Assembly
19	Power Assembly Rail (2)	Power Assembly Rail (2)

### Limited Warranty

Loren Cook Company warrants that your Loren Cook fan was manufactured free of defects in materials and workmanship, to the extent stated herein. For a period of one (1) year after date of shipment, we will replace any parts found to be defective without charge, except for shipping costs which will be paid by you.

This warranty is granted only to the original purchaser placing the fan in service.

This warranty is void if the fan or any part thereof has been altered or modified from its original design or has been abused, misused, damaged or is in worn condition or if the fan has been used other than for the uses described in the company manual. This warranty does not cover defects resulting from normal wear and tear.

To make a warranty claim, notify Loren Cook Company, General Offices, 2015 East Dale Street, Springfield, Missouri 65803-4637, explaining in writing, in detail, your complaint and referring to the specific model and serial numbers of your fan. Upon receipt by Loren Cook Company of your written complaint, you will be notified, within thirty (30) days of our receipt of your complaint, in writing, as to the manner in which your claim will be handled. If you are entitled to warranty relief, a warranty adjustment will be completed within sixty (60) business days of the receipt of your written complaint by Loren Cook Company.

This warranty gives only the original purchaser placing the fan in service specifically the right. You may have other legal rights which vary from state to state.

For fans provided with motors, the motor manufacturer warrants motors for a designated period stated in the manufacturer's warranty. Warranty periods vary from manufacturer to manufacturer. Should motors furnished by Loren Cook Company prove defective during the designated period, they should be returned to the nearest authorized motor service station. Loren Cook Company will not be responsible for any removal or installation costs.

## LOREN COOK COMPANY

Corporate Offices: 2015 E. Dale Street Springfield, MO 65803 417.869.6474  
lorencook.com