



# COOK ACRUD/ACRUD-HP/ACRUD-XP

DATE: \_\_\_\_\_  
 PROJECT: \_\_\_\_\_  
 LOCATION: \_\_\_\_\_



Upblast Centrifugal  
 Exhaust Ventilator

Hurricane / Missile Impact Resistant



Roof Mounted/Direct Drive

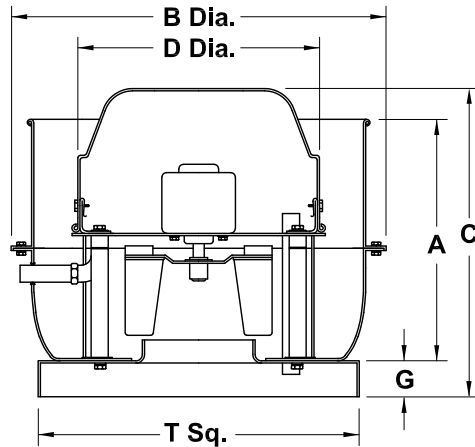

Sizes 70-100

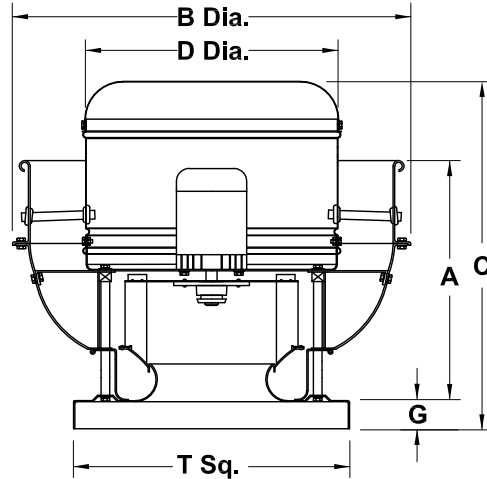

Sizes 120-195

**DIMENSION DATA**

Size	A	B	C			D	G	T Sq.	Ship Wt.	Roof Opening Sq.*
			ACRUD	ACRUD-HP	ACRUD-XP					
70	11	17-1/8	13-3/8	-	-	10-5/8	2	18	20	13-1/2
90	13-1/2	21-1/8	16-3/8	-	-	13-7/16	2	18	28	13-1/2
100	13-1/2	21-1/8	16-3/8	-	-	13-7/16	2	18	30	13-1/2
120	19-1/16	30-3/16	28-1/8	-	-	20-1/8	2	20	67	15-1/2
135	19-1/16	30-3/16	28-5/8	-	-	20-1/8	2	20	72	15-1/2
150	20-15/16	34-11/16	30-1/4	27-1/2	-	23-9/16	2	24	87	19-1/2
165	20-15/16	34-11/16	30-3/4	27-3/4	26-11/16	23-9/16	2	24	90	19-1/2
180	24-13/16	39-7/16	35-7/8	33-3/8	31-9/16	25-7/8	3	30	102	25-1/2
195	24-13/16	39-7/16	-	33-1/2	32-1/8	25-7/8	3	30	112	25-1/2

ALL DIMENSIONS IN INCHES. WEIGHTS IN LBS.  
 \* ROOF OPENING SIZE FOR CURBS SUPPLIED BY COOK ONLY.

**MIAMI-DADE COUNTY, FLORIDA**

Notice of Acceptance (NOA) Number 17-0925.02/11-13-2023

-TAS-201: Large Missile Impact Test

-TAS-202: Uniform Static Air Pressure Test

-TAS-203: Cyclic Wind Pressure Test

FBC PRODUCT APPROVAL NUMBER: FL11695

**STANDARD CONSTRUCTION FEATURES:**

- All aluminum housing - Backward inclined all aluminum wheel -
- Removeable top cap - Welded curb cap corners - Birdscreen -
- Permanently lubricated sealed bearing motors - Corrosion resistant fasteners - Transit tested packaging.

**ACCESSORIES**

1. DISCONNECT SWITCH
2. GRAVITY BACKDRAFT DAMPER
3. MOTORIZED BACKDRAFT DAMPER
4. RCG GALVANIZED CURB
5. RCA ALUMINUM CURB
6. FAN SPEED CONTROL
7. EPOXY COATING
8. ANTI-CONDENSATE COATING
9. GREASE TERMINATOR
10. LESS BIRDSCREEN

QTY	MARK	CATALOG NUMBER	FAN INFORMATION			MOTOR INFORMATION					ACCESSORIES		
			CFM	SP	RPM	HP	VOLTS	HZ	PH	TYPE			

MOTOR TYPE: ODP (OPEN DRIP-PROOF); 2 SP (2 SPEED); X-PRF (EXPLOSION PROOF); TEFC (TOTALLY ENCLOSED FAN COOLED).

AC012R02