

DATE: _____

PROJECT: _____

LOCATION: _____

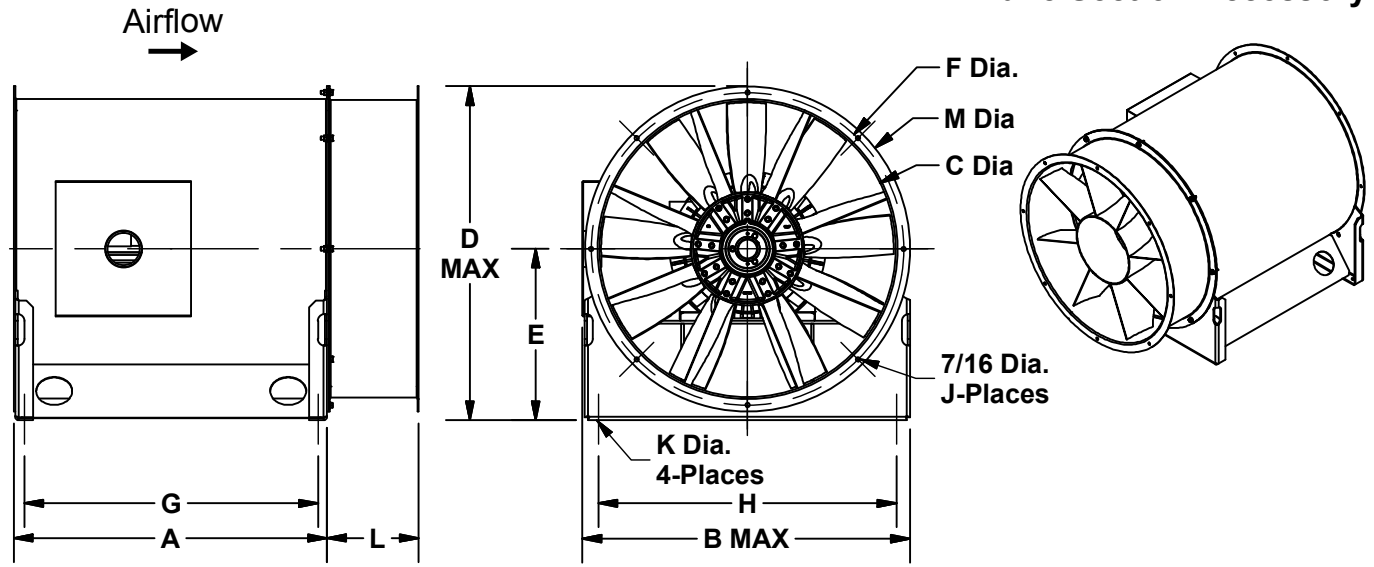

Axial Inline Fan
Horizontal Mount
Direct Drive
Arrangement 4, Level II
Vane Section Accessory

STANDARD CONSTRUCTION FEATURES:

High efficiency, heavy duty cast aluminum impeller - Continuously welded steel housing with Lorenized powder coating - Integral pre-punched inlet and outlet flanges - Corrosion resistant fasteners - Lifting Lugs - Rigid motor support welded to housing - Totally enclosed motor - Motor leads extended to exterior of the housing to a NEMA 1 wiring compartment

DIMENSION DATA

Size	A	B	C	D	E	F	G	H	J	K	L	M	Max Motor Frame	Unit Wt.
41	25	19 1/2	16 1/2	19 5/8	10	18 1/8	23 5/16	16 1/4	8	1/2	10	19	215T	107
47	25	21 7/8	18 5/8	22 5/16	11 7/16	20 1/4	23 5/16	18 3/4	8	1/2	10	22	215T	134
54	30	24 7/8	21 5/8	25 1/4	12 7/8	23 5/16	27 3/4	21 3/4	8	1/2	10	25	256T	201
63	30	28	24 5/8	28 15/16	15	26 5/16	27 3/4	24 7/8	8	1/2	10	28	256T	265
72	33	32 5/16	28 7/8	33 1/4	17 3/16	30 9/16	30 3/4	29 1/8	8	1/2	10	32	286T	339
80	35	36 3/8	32 7/8	37 1/8	19 1/16	34 3/4	32 5/8	33 1/8	8	9/16	10	36	326T	485
90	39	41 5/16	37	42 1/16	21 7/16	39 1/4	36 1/2	37 3/8	8	9/16	11 3/8	41	365T	739
103	39	45 5/8	41 1/8	47 1/4	24 9/16	43 3/8	36 1/2	41 1/2	8	9/16	12 3/8	45	365T	884
113	45	49 7/8	45 1/4	51 11/16	26 15/16	47 1/2	42 1/2	46 1/2	8	5/8	13 3/8	50	405T	1173
123	50	54 3/16	49 3/8	56 5/16	29 5/16	51 5/8	47 1/2	50 3/4	16	5/8	14 3/8	54	445T	1422
140	50	61	56	63 11/16	33 3/8	58 1/4	47 1/2	57 3/8	16	5/8	15 7/8	61	445T	1729
160	50	69 1/4	64 1/8	70 3/4	36 1/8	66 3/8	47 1/2	65 1/2	16	5/8	17 13/16	69	445T	1988

ALL DIMENSIONS IN INCHES. WEIGHTS IN LBS., LESS MOTOR.