



COOK

CA SWSI

DATE: _____

PROJECT: _____

LOCATION: _____



Airfoil Centrifugal Blower Clockwise Down Blast Arrangement 1* & 9

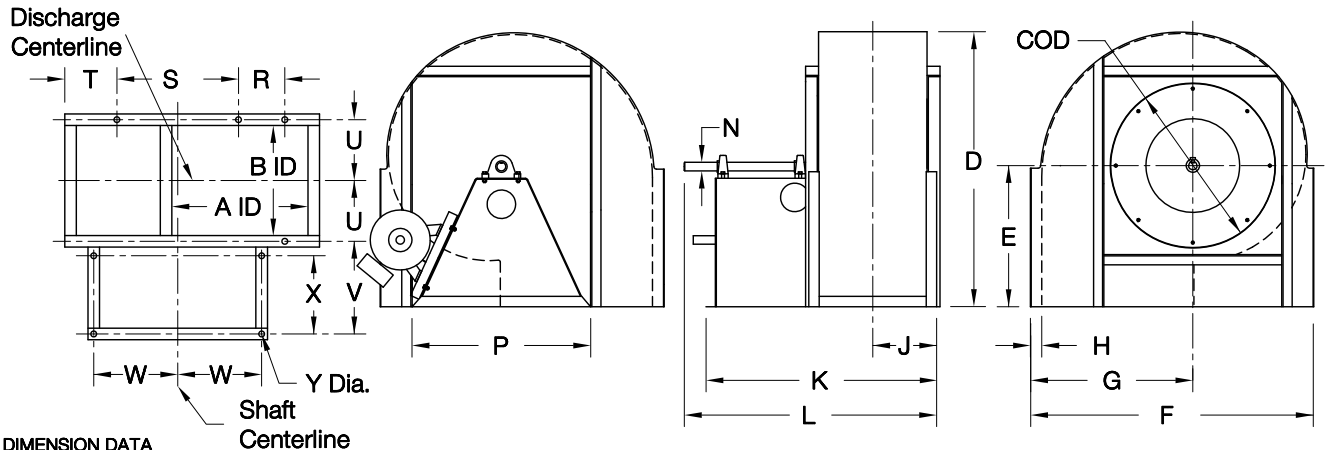

DIMENSION DATA

Size	A	B	C	D	E	F	G	H	J	K	L	N		
												Class I	Class II	Class III
120	13-1/8	9-3/16	16-1/8	24-3/8	13	25-3/4	15-1/16	2	6-5/8	25-1/4	26-1/4	1-3/16	1-7/16	1-11/16
135	14-3/4	10-5/16	17-5/8	25-9/16	14	28-3/4	16-11/16	2	7-3/16	26-3/8	27-3/8	1-3/16	1-7/16	1-11/16
150	16-7/16	11-7/16	19-1/8	29-1/4	15	31-5/8	18-5/16	2	7-3/4	29-1/2	30-1/2	1-3/16	1-7/16	1-11/16
165	18-1/16	12-5/8	21-3/16	32-5/8	17	34-3/8	19-15/16	2	8-5/16	30-5/8	32-5/8	1-3/16	1-7/16	1-11/16
180	19-11/16	13-3/4	22-11/16	35-1/8	18	37-1/8	21-9/16	2	8-7/8	33-3/4	36-1/4	1-7/16	1-11/16	1-11/16
195	21-5/16	14-15/16	24-3/16	38-1/2	20	40	23-3/16	2	9-1/2	35	37-1/2	1-7/16	1-11/16	1-11/16
210	23	16-1/16	25-15/16	40-15/16	21	42-7/8	24-7/8	2	10-1/16	38-1/8	41-1/8	1-7/16	1-11/16	1-15/16
225	24-5/8	17-3/16	27-7/16	44-3/8	23	45-3/4	26-1/2	2	10-5/8	39-1/4	42-1/4	1-7/16	1-11/16	1-15/16
245	26-13/16	18-3/4	29-7/16	48-1/4	25	49-1/2	28-5/8	2	11-3/8	42-3/4	46-1/4	1-11/16	1-15/16	2-3/16
270	29-9/16	20-5/8	31-15/16	50-1/8	27	54-3/4	31-3/8	2	12-5/16	44-5/8	48-5/8	1-11/16	1-15/16	2-3/16
300	32-13/16	22-15/16	34-15/16	58-1/2	30	60	34-5/8	2	13-1/2	49	53-1/2	1-15/16	2-3/16	2-7/16
330	36-1/8	25-1/4	37-15/16	64-3/8	33	65-3/4	37-7/8	2	14-5/8	51-1/4	56-1/4	1-15/16	2-3/16	2-7/16
365	39-15/16	27-7/8	41-7/16	70-5/8	36	72-3/8	41-3/4	2	15-15/16	57-3/4	63-1/4	2-3/16	2-7/16	2-15/16
402	44-1/16	30-3/4	45-3/16	78-1/4	40	80-3/8	46-3/4	3	18-3/8	62-11/16	67-11/16	2-3/16	2-7/16	2-15/16
445	48-11/16	34	49-7/16	86-1/4	44	88-1/2	51-3/8	3	20	69-15/16	75-7/16	2-7/16	2-15/16	3-7/16
490	53-5/8	37-7/16	55	94-1/2	48	97	56-1/4	3	21-3/4	73-7/16	79-7/16	2-7/16	2-15/16	3-7/16
540	59-1/16	41-1/4	60	104-1/4	53	106-5/8	61-3/4	3	23-5/8	81-3/16	87-11/16	2-15/16	3-7/16	3-15/16
600	65-5/8	45-13/16	66	116	59	118	68-1/4	3	25-15/16	85-11/16	92-11/16	2-15/16	3-7/16	3-15/16
660	72-3/16	50-7/16	72	121-5/8	65	129-3/8	74-3/4	3	28-1/4	94-7/16	101-15/16	3-7/16	3-15/16	4-7/16
730	79-7/8	55-3/4	79	141-5/16	72	142-5/8	82-3/8	3	30-7/8	99-11/16	107-11/16	3-7/16	3-15/16	4-7/16

Size	P	R	S	T	U	V	W	X	Y	Max Mtr Frame	Ship Wt
120	18-3/8	-	15	3-3/16	5-3/4	12-1/8	8-7/16	9-3/4	11/16	145T	215
135	19-7/8	-	17	3-9/16	6-5/16	12-1/8	9-3/16	9-3/4	11/16	145T	271
150	21-3/8	-	18	4-5/16	6-7/8	14-1/8	9-15/16	11-3/4	11/16	184T	331
165	23-3/8	-	20	4-7/16	7-7/16	14-1/8	10-15/16	11-3/4	11/16	184T	395
180	24-7/8	-	22	4-9/16	8	16-1/8	11-11/16	13-3/4	11/16	215T	462
195	26-3/8	9	23	5-5/16	8-5/8	16-1/8	12-7/16	13-3/4	11/16	215T	533
210	28-1/8	10	24	6	9-3/16	18-1/8	13-5/16	15-3/4	13/16	254T	608
225	29-5/8	10	25	6-3/4	9-3/4	18-1/8	14-1/16	15-3/4	13/16	254T	687
245	31-5/8	11	27	7-3/8	10-1/2	20-1/8	15-1/16	17-3/4	13/16	284T	797
270	34-3/8	12	30	8-3/8	11-7/16	20-1/8	16-7/16	17-3/4	13/16	284T	945
300	37-3/8	14	33	8-7/8	12-5/8	22-1/8	17-15/16	19-3/4	13/16	324T	1135
330	40-3/8	16	36	9-7/8	13-3/4	22-1/8	19-7/16	19-3/4	13/16	324T	1341
365	44-7/8	17	40	10-5/8	15-1/16	26	21-11/16	23-3/4	13/16	326T	1600
402	48-3/4	20	44	11-5/8	17-1/8	26-3/16	23-3/8	23-3/4	1-1/16	326T	1895
445	53	23	48	13-1/8	18-3/4	30-3/16	25-1/2	27-3/4	1-1/16	326T	2268
490	58-1/2	26	53	14-1/4	20-1/2	30-3/16	28-1/4	27-3/4	1-1/16	404T	2690
540	63-1/2	29	58	15-7/8	22-3/8	34-3/16	30-3/4	31-3/4	1-1/16	404T	3199
600	69-1/2	32	64	17-3/4	24-5/8	34-3/16	33-3/4	31-3/4	1-1/16	404T	3864
660	75-1/2	36	70	19-5/8	27	38-3/16	36-3/4	35-3/4	1-1/16	404T	4589
730	82-1/2	40	77	21-3/4	29-5/8	38-3/16	40-1/4	35-3/4	1-1/16	404T	5510

ALL DIMENSIONS IN INCHES. WEIGHTS IN LBS., LESS MOTOR. MAXIMUM MOTOR FRAME BASED ON SINGLE SPEED ODP MOTORS (ARR. 9 ONLY).
* ARRANGEMENT 9 SHOWN. ARRANGEMENT 1 SIMILAR BUT WITHOUT MOTOR MOUNTING PROVISION. ** BASED ON CLASS I CONSTRUCTION.

CA005R03