



# COOK

# CA SWSI

DATE: \_\_\_\_\_

PROJECT: \_\_\_\_\_

LOCATION: \_\_\_\_\_



## Airfoil Centrifugal Blower Clockwise Upblast Arrangement 10

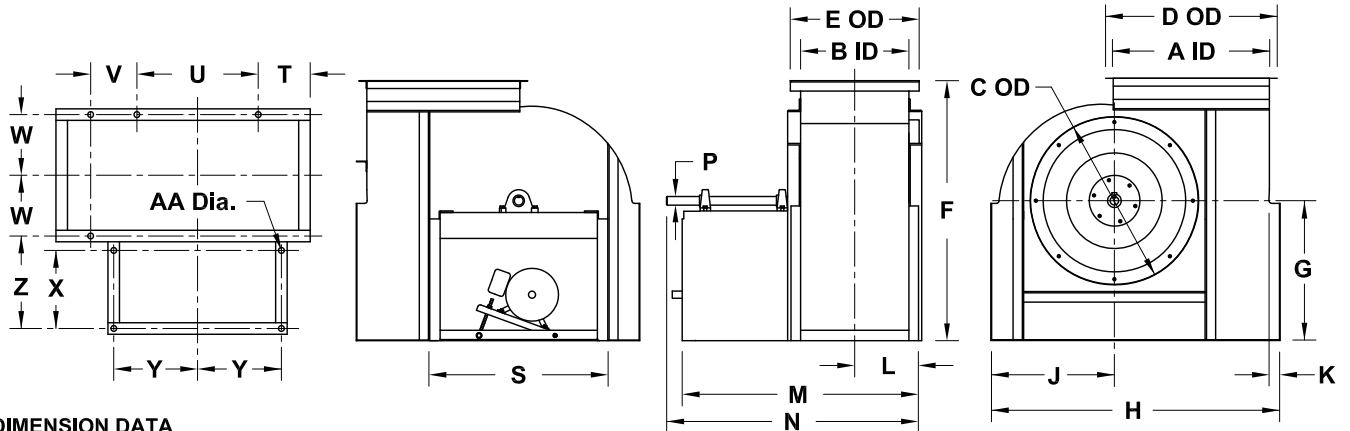

### DIMENSION DATA

Size	A	B	C	D	E	F	G	H	J	K	L	M	N
120	13-1/8	9-3/16	16-1/8	16-5/16	12-3/8	23-5/8	13	25-3/4	10-11/16	2	6-5/8	26-1/4	26-1/4
135	14-3/4	10-5/16	17-5/8	17-5/16	13-1/2	27-5/8	14	28-3/4	12-1/16	2	7-3/16	27-3/8	27-3/8
150	16-7/16	11-7/16	19-1/8	19-5/8	14-5/8	28-3/16	15	31-5/8	13-5/16	2	7-3/4	30-1/2	30-1/2
165	18-1/16	12-5/8	21-3/16	21-1/4	15-13/16	31-1/2	17	34-3/8	14-11/16	2	8-5/16	31-5/8	32-5/8
180	19-11/16	13-3/4	22-11/16	22-7/8	16-15/16	33-3/4	18	37-1/8	15-9/16	2	8-7/8	34-3/4	36-1/4
195	21-5/16	14-15/16	24-3/16	24-1/2	18-3/16	37-1/16	20	40	16-13/16	2	9-1/2	36	37-1/2
210	23	16-1/16	25-15/16	26-3/16	19-5/16	39-3/8	21	42-7/8	18	2	10-1/16	39-1/8	41-1/8
225	24-5/8	17-3/16	27-7/16	27-13/16	20-7/16	42-5/8	23	45-3/4	19-1/4	2	10-5/8	40-1/4	42-1/4
245	26-13/16	18-3/4	29-7/16	30	22	46-3/8	25	49-1/2	20-7/8	2	11-3/8	43-3/4	46-1/4
270	29-9/16	20-5/8	31-15/16	32-3/4	23-7/8	50-1/2	27	54-3/4	23-3/8	2	12-5/16	45-5/8	48-5/8
300	32-13/16	22-15/16	34-15/16	36	26-3/16	56-1/8	30	60	25-3/8	2	13-1/2	50	53-1/2
330	36-1/8	25-1/4	37-15/16	40-5/16	29-7/16	61-5/8	33	65-3/4	27-7/8	2	14-5/8	52-1/4	56-1/4
365	39-15/16	27-7/8	41-7/16	44-3/16	32-1/16	67-11/16	36	72-3/8	30-5/8	2	15-15/16	58-3/4	63-1/4
402	44-1/16	30-3/4	45-3/16	48-5/16	34-15/16	74-15/16	40	80-3/8	33-5/8	3	18-3/8	63-11/16	67-11/16
445	48-11/16	34	49-7/16	52-15/16	38-3/16	82-9/16	44	88-1/2	37-1/8	3	20	70-15/16	75-7/16
490	53-5/8	37-7/16	55	57-7/8	41-5/8	90-7/16	48	97	40-3/4	3	21-3/4	73-7/16	79-7/16
540	59-1/16	41-1/4	60	63-5/16	45-7/16	99-3/4	53	106-5/8	44-7/8	3	23-5/8	81-3/16	87-11/16
600	65-5/8	45-13/16	66	70	50-3/16	110-15/16	59	118	49-3/4	3	25-15/16	85-11/16	92-11/16
660	72-3/16	50-7/16	72	76-9/16	54-13/16	122-1/8	65	129-3/8	54-5/8	3	28-1/4	94-7/16	101-15/16
730	79-7/8	55-3/4	79	84-1/4	60-1/8	135-1/8	72	142-5/8	60-1/4	3	30-7/8	99-11/16	107-11/16

Size	P			S	T	U	V	W	X	Y	Z	AA	Max Mtr Frame	Ship Wt *
	Class I	Class II	Class III											
120	1-3/16	1-7/16	1-11/16	18-3/8	3-3/16	15	-	5-3/4	9-3/4	8-7/16	12-1/8	11/16	145T	215
135	1-3/16	1-7/16	1-11/16	19-7/8	3-9/16	17	-	6-5/16	9-3/4	9-3/16	12-1/8	11/16	145T	271
150	1-3/16	1-7/16	1-11/16	21-3/8	4-5/16	18	-	6-7/8	11-3/4	9-15/16	14-1/8	11/16	184T	331
165	1-3/16	1-7/16	1-11/16	23-3/8	4-7/16	20	-	7-7/16	11-3/4	10-15/16	14-1/8	11/16	184T	395
180	1-7/16	1-11/16	1-11/16	24-7/8	4-9/16	22	-	8	13-3/4	11-11/16	16-1/8	11/16	215T	462
195	1-7/16	1-11/16	1-11/16	26-3/8	5-5/16	23	9	8-5/8	13-3/4	12-7/16	16-1/8	11/16	215T	533
210	1-7/16	1-11/16	1-15/16	28-1/8	6	24	10	9-3/16	15-3/4	13-5/16	18-1/8	13/16	254T	608
225	1-7/16	1-11/16	1-15/16	29-5/8	6-3/4	25	10	9-3/4	15-3/4	14-1/16	18-1/8	13/16	254T	687
245	1-11/16	1-15/16	2-3/16	31-5/8	7-3/8	27	11	10-1/2	17-3/4	15-1/16	20-1/8	13/16	284T	797
270	1-11/16	1-15/16	2-3/16	34-3/8	8-3/8	30	12	11-7/16	17-3/4	16-7/16	20-1/8	13/16	284T	945
300	1-15/16	2-3/16	2-7/16	37-3/8	8-7/8	33	14	12-5/8	19-3/4	17-15/16	22-1/8	13/16	324T	1135
330	1-15/16	2-3/16	2-7/16	40-3/8	9-7/8	36	16	13-3/4	19-3/4	19-7/16	22-1/8	13/16	324T	1341
365	2-3/16	2-7/16	2-15/16	44-7/8	10-5/8	40	17	15-1/16	23-3/4	21-11/16	26	13/16	326T	1600
402	2-3/16	2-7/16	2-15/16	48-3/4	11-5/8	44	20	17-1/8	23-3/4	23-3/8	26-3/16	1-1/16	326T	1895
445	2-7/16	2-15/16	3-7/16	53	13-1/8	48	23	18-3/4	27-3/4	25-1/2	30-3/16	1-1/16	326T	2268
490	2-7/16	2-15/16	3-7/16	58-1/2	14-1/4	53	26	20-1/2	27-3/4	28-1/4	30-3/16	1-1/16	404T	2690
540	2-15/16	3-7/16	3-15/16	63-1/2	15-7/8	58	29	22-3/8	31-3/4	30-3/4	34-3/16	1-1/16	404T	3199
600	2-15/16	3-7/16	3-15/16	69-1/2	17-3/4	64	32	24-5/8	31-3/4	33-3/4	34-3/16	1-1/16	404T	3864
660	3-7/16	3-15/16	4-7/16	75-1/2	19-5/8	70	36	27	35-3/4	36-3/4	38-3/16	1-1/16	404T	4589
730	3-7/16	3-15/16	4-7/16	82-1/2	21-3/4	77	40	29-5/8	35-3/4	40-1/4	38-3/16	1-1/16	404T	5510

ALL DIMENSIONS IN INCHES. WEIGHTS IN LBS., LESS MOTOR. MAXIMUM MOTOR FRAME BASED ON SINGLE SPEED ODP MOTORS.  
 \* BASED ON CLASS I CONSTRUCTION.

CA010R02