

MARK: _____

PROJECT: _____

DATE: _____



**Centrifugal Airfoil Blower
Clockwise Top Horizontal
Arrangement 3
Low Profile
Class I**

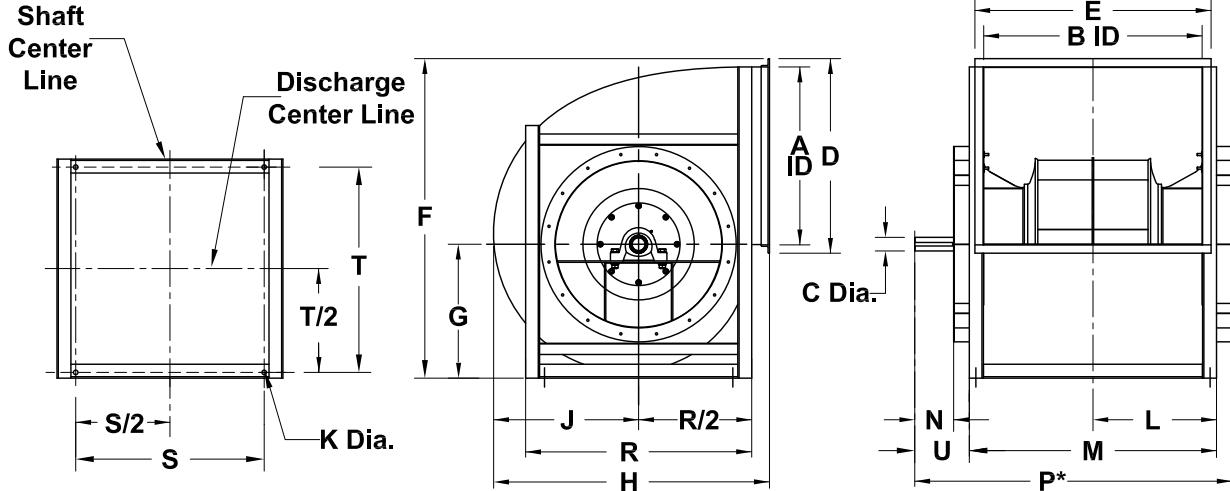

DIMENSION DATA

Size	A	B	C	D	E	F	G	H	J	K
120	12-1/8	17-11/16	1-7/16	14-1/4	19-13/16	23-15/16	10-3/16	20-1/16	10-7/16	9/16
135	13-5/8	19-15/16	1-7/16	15-3/4	22-1/16	26-11/16	11-5/16	22-9/16	11-3/4	9/16
150	15-1/4	22	1-7/16	17-3/8	24-1/8	29-3/8	12-7/16	25-1/16	13-1/16	9/16
165	16-15/16	24	1-11/16	19-1/16	26-1/8	32-1/16	13-9/16	27-1/2	14-3/8	15/16
180	18-1/2	26-1/16	1-11/16	20-5/8	28-3/16	34-7/8	14-3/4	30	15-11/16	15/16
195	19-1/2	28-7/16	1-11/16	21-11/16	30-5/8	37-5/8	15-7/8	32-7/16	16-15/16	15/16
210	21-5/8	30-3/8	1-11/16	23-13/16	32-9/16	40-3/8	17	34-15/16	18-1/4	15/16
225	23-3/16	32-1/2	1-15/16	26-3/8	35-11/16	43-5/8	18-3/16	37-3/8	19-9/16	15/16
245	25-1/2	35-1/16	1-15/16	28-11/16	38-1/4	47-1/4	19-11/16	40-11/16	21-5/16	15/16
270	27-1/2	39-7/16	2-3/16	30-11/16	42-5/8	51-13/16	21-5/8	44-13/16	23-1/2	15/16
300	31-3/16	43	2-3/16	34-3/8	46-3/16	57-1/4	23-7/8	49-3/4	26-1/16	15/16
330	34-1/2	47-1/16	2-7/16	38-3/4	51-5/16	63-1/4	26-3/16	54-11/16	28-11/16	15/16
365	38-11/16	52-3/16	2-11/16	42-15/16	56-7/16	69-5/8	28-7/8	60-1/2	31-3/4	15/16
402	41-3/4	57-13/16	2-15/16	46-1/16	62	76-3/8	31-11/16	66-9/16	34-15/16	15/16
445	45-15/16	64-1/4	2-15/16	50-5/16	68-9/16	84-3/16	34-15/16	73-11/16	38-11/16	1-1/16
490	51	70-1/8	3-7/16	55-3/8	74-7/16	92-3/8	38-3/8	81-1/8	42-9/16	1-1/16
540	55-3/4	77-15/16	2-15/16	60-1/8	82-3/16	101-5/8	42-5/16	89-3/8	46-15/16	1-1/16
600	62-3/16	86-1/4	2-15/16	66-9/16	90-9/16	112-11/16	47	99-5/16	52-3/16	1-1/16
660	68-7/16	94-7/8	3-7/16	72-13/16	99-1/4	123-3/4	51-11/16	109-3/16	57-3/8	1-1/16
730	75-13/16	104-3/4	3-7/16	81-3/16	110-1/8	137-1/8	57-3/16	120-11/16	63-7/16	1-1/16

*P dimension is the overall width.

Size	L	M	N	P	R	S	T	U	Approx. Ship Wt.
120	10-7/16	20-13/16	2-3/4	26-11/16	19-1/4	14-7/8	19-1/2	4-5/16	182
135	11-9/16	23-1/16	2-3/4	28-15/16	21	16-5/8	21-3/4	4-5/16	204
150	13-1/16	26-1/8	3-3/8	31-5/8	22-1/2	17-3/4	24-3/8	4-7/16	246
165	14-1/16	28-1/8	3-3/8	33-11/16	24-1/4	19-1/2	26-3/8	4-7/16	293
180	15-1/8	30-3/16	3-3/4	36-1/8	26-3/4	21	28-7/16	4-13/16	335
195	16-5/16	32-9/16	3-3/4	38-1/2	28-1/2	22-3/4	30-13/16	4-13/16	367
210	17-1/4	34-1/2	3-3/4	41-7/16	30	24-1/4	32-3/4	5-13/16	403
225	18-5/16	36-5/8	4-1/4	44-1/16	31-3/4	26	34-7/8	6-5/16	495
245	19-5/8	39-3/16	4-1/4	46-5/8	33-3/4	28	37-7/16	6-5/16	547
270	22-5/16	44-9/16	4-1/4	51-1/2	37-1/2	30-1/4	42-5/16	6-5/16	663
300	24-1/16	48-1/8	4-1/4	55-1/8	40-1/2	33-1/4	45-7/8	6-3/8	820
330	26-5/8	53-3/16	4-3/8	59-5/16	41-9/16	36-1/8	50-9/16	6	948
365	29-3/16	58-5/16	4-3/4	65-5/16	45-5/16	39-7/8	55-11/16	6-7/8	1148
402	33	65-15/16	4-7/8	71-15/16	49-11/16	43	62-7/16	6	1453
445	36-1/4	72-7/16	5-3/4	79-5/16	53-15/16	47-1/4	68-15/16	6-7/8	1879
490	39-3/16	78-5/16	5-7/8	85-5/16	58-11/16	52	74-13/16	7	2238
540	43-1/16	86-1/8	6-1/4	93-1/2	63-11/16	57	82-5/8	7-3/8	2492
600	48-1/4	96-1/2	6-1/4	102-7/8	70	62	92	6-3/8	3501
660	53-9/16	107-1/8	9-3/8	117-1/8	76-9/16	67	101-5/8	10	4528
730	58-1/2	117	9-3/8	127	83-9/16	74	111-1/2	10	5548

ALL DIMENSIONS IN INCHES. ALL WEIGHTS IN POUNDS, LESS MOTOR AND DRIVES.