

DATE: _____

PROJECT: _____

LOCATION: _____



Airfoil Centrifugal Blower Clockwise Top Horizontal Arrangement 4

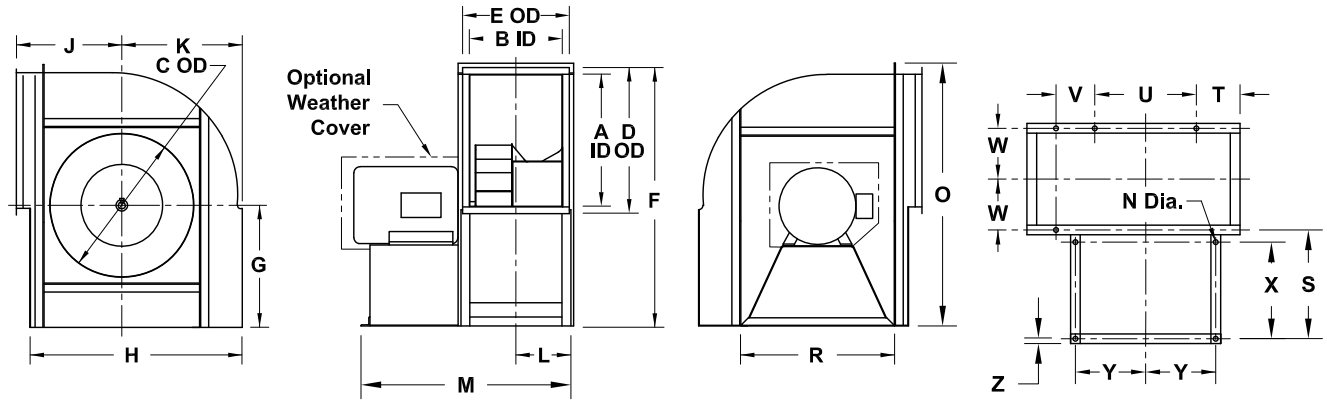

DIMENSION DATA

Size	A	B	C	D	E	F	G	H	J	K	L	M	N	O
120	13-1/8	9-3/16	16-1/8	16-5/16	12-3/8	27-11/16	13	21-1/2	12-3/8	12-3/8	6-5/8	23-3/4	11/16	-
135	14-3/4	10-5/16	17-5/8	17-5/16	13-1/2	30-5/16	14	24	13-3/8	13-7/8	7-3/16	24-7/8	11/16	-
150	16-7/16	11-7/16	19-1/8	19-5/8	14-5/8	32-15/16	15	26	14-1/16	15-3/16	7-3/4	28-1/4	11/16	-
165	18-1/16	12-5/8	21-3/16	21-1/4	15-13/16	36-9/16	17	28-1/2	15-1/8	16-5/8	8-5/16	29-3/8	11/16	-
180	19-11/16	13-3/4	22-11/16	22-7/8	16-15/16	39-1/4	18	30-3/4	15-7/8	18-1/8	8-7/8	34-1/4	11/16	-
195	21-5/16	14-15/16	24-3/16	24-1/2	18-3/16	42-7/8	20	33	17-1/16	19-7/16	9-1/2	35-1/2	11/16	-
210	23	16-1/16	25-15/16	26-3/16	19-5/16	45-9/16	21	38	20-1/4	21	10-1/16	36-5/8	13/16	46-1/16
225	24-5/8	17-3/16	27-7/16	27-13/16	20-7/16	49-1/8	23	40	20-7/8	22-3/8	10-5/8	39-1/4	13/16	49-5/8
245	26-13/16	18-3/4	29-7/16	30	22	53-1/4	25	43	22	26-1/4	11-3/8	42-1/4	13/16	53-3/4
270	29-9/16	20-5/8	31-15/16	32-3/4	23-7/8	58	27	47	23-5/8	26-5/8	12-5/16	45	13/16	58-1/2
300	32-13/16	22-15/16	34-15/16	36	26-3/16	64-1/4	30	52	26-1/8	29-1/2	13-1/2	47-3/8	13/16	64-3/4
330	36-1/8	25-1/4	37-15/16	40-5/16	29-7/16	71	33	57	28-11/16	32-5/16	14-5/8	51-7/8	13/16	71
365	39-15/16	27-7/8	41-7/16	44-3/16	32-1/16	77-7/8	36	63	31-11/16	35-9/16	15-15/16	58	13/16	77-7/8
402	44-1/16	30-3/4	45-3/16	48-5/16	34-15/16	85-15/16	40	69	34-15/16	39-3/16	18-3/8	62-15/16	1-1/16	87-7/16
445	48-11/16	34	49-7/16	52-15/16	38-3/16	94-1/2	44	77	38-9/16	43-3/16	20	74-11/16	1-1/16	96
490	53-5/8	37-7/16	55	57-7/8	41-5/8	103-3/8	48	85	42-7/16	47-9/16	21-3/4	78-3/16	1-1/16	104-7/8
540	59-1/16	41-1/4	60	63-5/16	45-7/16	113-15/16	53	94	46-3/4	52-1/4	23-5/8	81-15/16	1-1/16	115-7/16
600	65-5/8	45-13/16	66	70	50-3/16	126-3/8	59	105	51-15/16	57-15/16	25-15/16	86-7/16	1-1/16	129-3/8
660	72-3/16	50-7/16	72	76-9/16	54-13/16	138-15/16	65	116	57-1/8	64-3/4	28-1/4	91-3/16	1-1/16	141-15/16
730	79-7/8	55-3/4	79	84-1/4	60-1/8	153-1/2	72	129	63-1/8	70-3/8	30-7/8	96-7/16	1-1/16	156-1/2

Size	R	S	T	U	V	W	X	Y	Z	Max Mtr Frame
120	18-3/8	10-5/8	1-5/8	15	-	5-3/4	8-1/4	8-7/16	3/4	182T
135	19-7/8	10-5/8	1-5/8	17	-	6-5/16	8-1/4	9-3/16	3/4	184T
150	21-3/8	12-7/8	1-13/16	18	-	6-7/8	10-1/2	9-15/16	3/4	215T
165	23-3/8	12-7/8	1-7/8	20	-	7-7/16	10-1/2	10-15/16	3/4	215T
180	24-7/8	16-5/8	1-5/8	22	-	8	14-1/4	11-11/16	3/4	256T
195	26-3/8	16-5/8	2-1/16	23	6	8-5/8	14-1/4	12-7/16	3/4	256T
210	28-1/8	16-5/8	5	24	7	9-3/16	14-1/4	13-5/16	3/4	256T
225	29-5/8	18-1/8	5-1/8	25	7-1/2	9-3/4	15-3/4	14-1/16	3/4	284T
245	31-5/8	19-5/8	5-1/4	27	8	10-1/2	17-1/4	15-1/16	3/4	324T
270	34-3/8	20-1/2	5-3/8	30	9	11-7/16	18-1/8	16-7/16	3/4	364T
300	37-3/8	20-1/2	6	33	10	12-5/8	18-1/8	17-15/16	3/4	365T
330	40-3/8	22-3/4	6-11/16	36	12	13-3/4	20-3/8	19-7/16	3/4	404T
365	44-7/8	26-1/4	7-7/16	40	13	15-1/16	24	21-11/16	3/4	444T
402	48-3/4	26-7/16	7-13/16	44	14	17-1/8	24	23-3/8	1	445T
445	53	34-15/16	9-13/16	48	16	18-3/4	32-1/2	25-1/2	1	449T
490	58-1/2	34-15/16	10-15/16	53	18	20-1/2	32-1/2	28-1/4	1	449T
540	63-1/2	34-15/16	12-3/4	58	20	22-3/8	32-1/2	30-3/4	1	449T
600	69-1/2	34-15/16	15-11/16	64	22	24-5/8	32-1/2	33-3/4	1	449T
660	75-1/2	34-15/16	17-1/4	70	25	27	32-1/2	36-3/4	1	449T
730	82-1/2	34-15/16	20-1/8	77	28	29-5/8	32-1/2	40-1/4	1	449T

ALL DIMENSIONS IN INCHES.

FOR REDUCED WIDTH WHEELS

- B' = B - (Unit Size X 0.030 X Percent Reduced)
- E' = E - (Unit Size X 0.030 X Percent Reduced)
- L' = L - (Unit Size X 0.015 X Percent Reduced)
- M' = M - (Unit Size X 0.030 X Percent Reduced)
- W' = W - (Unit Size X 0.015 X Percent Reduced)

EXAMPLE: Size 300 Reduced 20%

- B' = 22.9375 - (300 X 0.030 X 0.20)
- B' = 22.9375 - (1.80)
- B' = 21.1375 OR 21-1/8