



# COOK

# CF SWSI

DATE: \_\_\_\_\_  
 PROJECT: \_\_\_\_\_  
 LOCATION: \_\_\_\_\_



**Flat Blade Centrifugal Blower**  
**Clockwise Top Horizontal**  
**Arrangement 10**

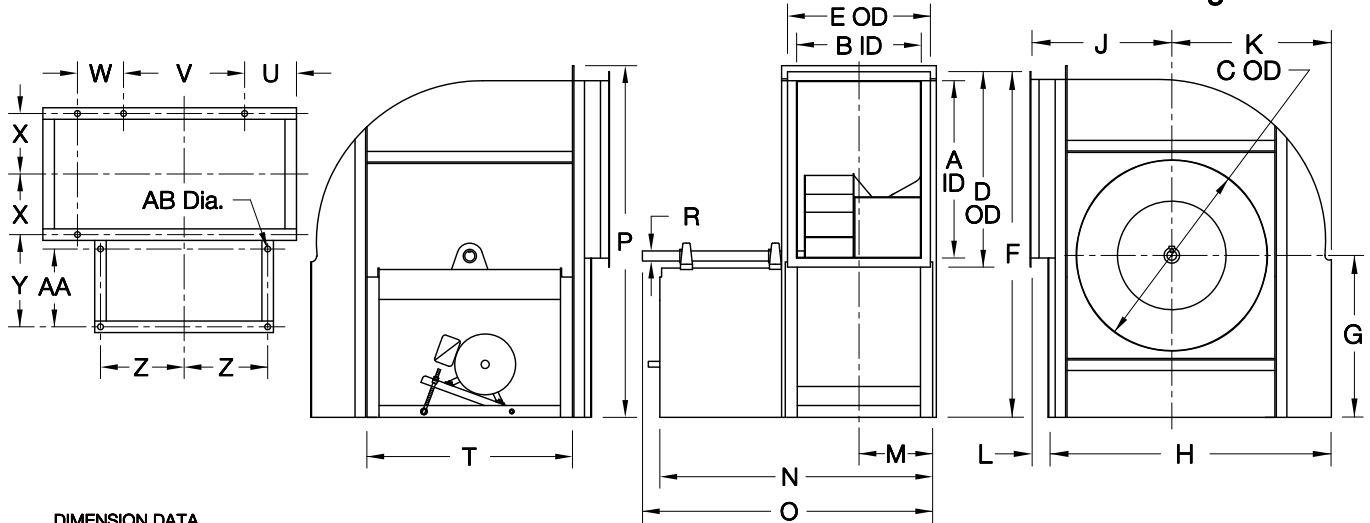

**DIMENSION DATA**

Size	A	B	C	D	E	F	G	H	J	K	L	M	N	O
120	13-1/8	9-3/16	16-1/8	16-5/16	12-3/8	27-11/16	13	21-1/2	12-3/8	12-3/8	3-1/4	6-5/8	26-1/4	26-1/4
135	14-3/4	10-5/16	17-5/8	17-15/16	13-1/2	30-5/16	14	24	13-3/8	13-7/8	3-1/4	7-3/16	27-3/8	27-3/8
150	16-7/16	11-7/16	19-1/8	19-5/8	14-5/8	32-15/16	15	26	14-1/16	15-3/16	3-1/4	7-3/4	30-1/2	30-1/2
165	18-1/16	12-5/8	21-3/16	21-1/4	15-13/16	36-9/16	17	28-1/2	15-1/8	16-5/8	3-1/4	8-5/16	31-5/8	32-5/8
180	19-11/16	13-3/4	22-11/16	22-7/8	16-15/16	39-1/4	18	30-3/4	15-7/8	18-1/8	3-1/4	8-7/8	34-3/4	36-1/4
195	21-5/16	14-15/16	24-3/16	24-1/2	18-3/16	42-7/8	20	33	17-1/16	19-7/16	3-1/2	9-1/2	36	37-1/2
210	23	16-1/16	25-15/16	26-3/16	19-5/16	45-9/16	21	38	20-1/4	21	3-1/4	10-1/16	39-1/8	41-1/8
225	24-5/8	17-3/16	27-7/16	27-13/16	20-7/16	49-1/8	23	40	20-7/8	22-3/8	3-1/4	10-5/8	40-1/4	42-1/4
245	26-13/16	18-3/4	29-7/16	30	22	53-1/4	25	43	22	24-1/4	3-1/4	11-3/8	43-3/4	46-1/4
270	29-9/16	20-5/8	31-15/16	32-3/4	23-7/8	58	27	47	23-5/8	26-5/8	3-1/4	12-5/16	45-5/8	48-5/8
300	32-13/16	22-15/16	34-15/16	36	26-3/16	64-1/4	30	52	26-1/8	29-1/2	3-5/8	13-1/2	50	53-1/2
330	36-1/8	25-1/4	37-15/16	40-5/16	29-7/16	71	33	57	28-11/16	32-5/16	4	14-5/8	52-1/4	56-1/4
365	39-15/16	27-7/8	41-7/16	44-3/16	32-1/16	77-7/8	36	63	31-11/16	35-9/16	4-1/4	15-15/16	58-3/4	63-1/4
402	44-1/16	30-3/4	45-3/16	48-5/16	34-15/16	85-15/16	40	69	34-15/16	39-3/16	5-1/8	18-3/8	63-11/16	67-11/16
445	48-11/16	34	49-7/16	52-15/16	38-3/16	94-1/2	44	77	38-9/16	43-3/16	4-3/4	20	70-15/16	75-7/16
490	53-5/8	37-7/16	55	57-7/8	41-5/8	103-3/8	48	85	42-7/16	47-9/16	5	21-3/4	73-7/16	79-7/16
540	59-1/16	41-1/4	60	63-5/16	45-7/16	113-15/16	53	94	46-3/4	52-1/4	5	23-5/8	81-3/16	87-11/16
600	65-5/8	45-13/16	66	70	50-3/16	126-3/8	59	105	51-15/16	57-15/16	4-7/8	25-15/16	85-11/16	92-11/16
660	72-3/16	50-7/16	72	76-9/16	54-13/16	138-15/16	65	116	57-1/8	64-3/4	4-7/8	28-1/4	94-7/16	101-15/16
730	79-7/8	55-3/4	79	84-1/4	60-1/8	153-1/2	72	129	63-1/8	70-3/8	4-1/2	30-7/8	99-11/16	107-11/16

Size	P	R			T	U	V	W	X	Y	Z	AA	AB	Max Mtr Frame	Ship Wt **
		Class I	Class II	Class III											
120	-	1-3/16	1-7/16	1-11/16	18-3/8	1-5/8	15	-	5-3/4	12-1/8	8-7/16	9-3/4	11/16	145T	211
135	-	1-3/16	1-7/16	1-11/16	19-7/8	1-5/8	17	-	6-5/16	12-1/8	9-3/16	9-3/16	11/16	145T	266
150	-	1-3/16	1-7/16	1-11/16	21-3/8	1-13/16	18	-	6-7/8	14-1/8	9-15/16	11-3/4	11/16	184T	325
165	-	1-3/16	1-7/16	1-11/16	23-3/8	1-7/8	20	-	7-7/16	14-1/8	10-15/16	11-3/4	11/16	184T	387
180	-	1-7/16	1-11/16	1-11/16	24-7/8	1-5/8	22	-	8	16-1/8	11-11/16	13-3/4	11/16	215T	453
195	-	1-7/16	1-11/16	1-11/16	26-3/8	2-1/16	23	6	8-5/8	16-1/8	12-7/16	13-3/4	11/16	215T	523
210	46-1/16	1-7/16	1-11/16	1-15/16	28-1/8	5	24	7	9-3/16	18-1/8	13-5/16	15-3/4	13/16	254T	599
225	49-5/8	1-7/16	1-11/16	1-15/16	29-5/8	5-1/8	25	7-1/2	9-3/4	18-1/8	14-1/16	15-3/4	13/16	254T	677
245	53-3/4	1-11/16	1-15/16	2-3/16	31-5/8	5-1/4	27	8	10-1/2	20-1/8	15-1/16	17-3/4	13/16	284T	786
270	58-1/2	1-11/16	1-15/16	2-3/16	34-3/8	5-3/8	30	9	11-7/16	20-1/8	16-7/16	17-3/4	13/16	284T	931
300	64-3/4	1-15/16	2-3/16	2-7/16	37-3/8	6	33	10	12-5/8	22-1/8	17-15/16	19-3/4	13/16	324T	1118
330	71	1-15/16	2-3/16	2-7/16	40-3/8	6-11/16	36	12	13-3/4	22-1/8	19-7/16	19-3/4	13/16	324T	1320
365	77-7/8	2-3/16	2-7/16	2-15/16	44-7/8	7-7/16	40	13	15-1/16	26	21-11/16	23-3/4	13/16	326T	1575
402	87-7/16	2-3/16	2-7/16	2-15/16	48-3/4	7-13/16	44	14	17-1/8	26-3/16	23-3/8	23-3/4	1-1/16	326T	1858
445	96	2-7/16	2-15/16	3-7/16	53	9-13/16	48	16	18-3/4	30-3/16	25-1/2	27-3/4	1-1/16	326T	2223
490	104-7/8	2-7/16	2-15/16	3-7/16	58-1/2	10-15/16	53	18	20-1/2	30-3/16	28-1/4	27-3/4	1-1/16	404T	2636
540	115-7/16	2-15/16	3-7/16	3-15/16	63-1/2	12-3/4	58	20	22-3/8	34-3/16	30-3/4	31-3/4	1-1/16	404T	3190
600	129-3/8	2-15/16	3-7/16	3-15/16	69-1/2	15-1/16	64	22	24-5/8	34-3/16	33-3/4	31-3/4	1-1/16	404T	3852
660	141-15/16	3-7/16	3-15/16	4-7/16	75-1/2	17-1/4	70	25	27	38-3/16	36-3/4	35-3/4	1-1/16	404T	4576
730	156-1/2	3-7/16	3-15/16	4-7/16	82-1/2	20-1/8	77	28	29-5/8	38-3/16	40-1/4	35-3/4	1-1/16	404T	5495

ALL DIMENSIONS IN INCHES. WEIGHTS IN LBS., LESS MOTOR. MAXIMUM MOTOR FRAME BASED ON SINGLE SPEED ODP MOTORS.

\*\* BASED ON CLASS I CONSTRUCTION.

CF002R02