



# COOK

# CF SWSI

DATE: \_\_\_\_\_  
 PROJECT: \_\_\_\_\_  
 LOCATION: \_\_\_\_\_



Flat Blade Centrifugal Blower  
 Counterclockwise Down Blast  
 Arrangement 10

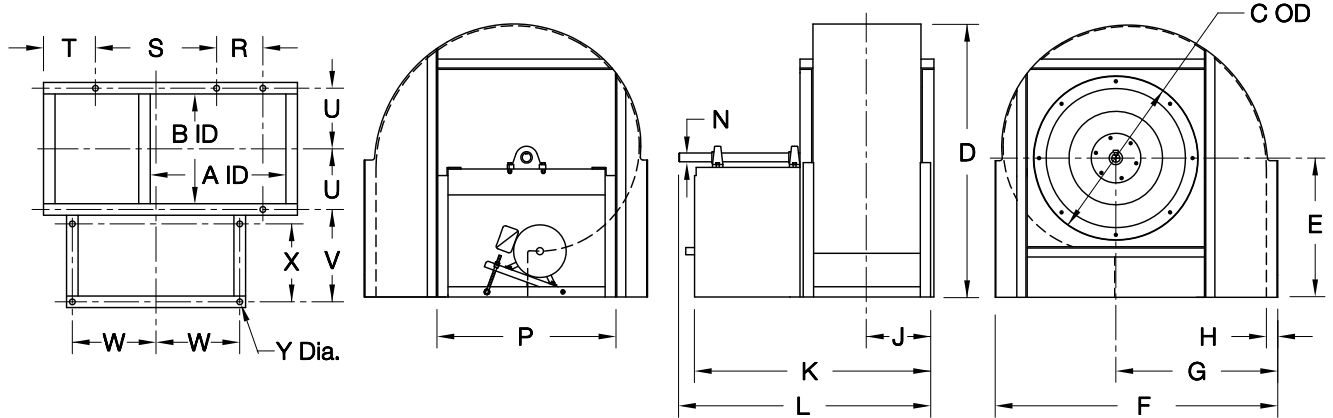

**DIMENSION DATA**

| Size | A        | B        | C        | D        | E  | F       | G        | H | J        | K        | L         | N       |          |           |
|------|----------|----------|----------|----------|----|---------|----------|---|----------|----------|-----------|---------|----------|-----------|
|      |          |          |          |          |    |         |          |   |          |          |           | Class I | Class II | Class III |
| 120  | 13-1/8   | 9-3/16   | 16-1/8   | 24-3/8   | 13 | 25-3/4  | 15-1/16  | 2 | 6-5/8    | 25-1/4   | 26-1/4    | 1-3/16  | 1-7/16   | 1-11/16   |
| 135  | 14-3/4   | 10-5/16  | 17-5/8   | 25-9/16  | 14 | 28-3/4  | 16-11/16 | 2 | 7-3/16   | 26-3/8   | 27-3/8    | 1-3/16  | 1-7/16   | 1-11/16   |
| 150  | 16-7/16  | 11-7/16  | 19-1/8   | 29-1/4   | 15 | 31-5/8  | 18-5/16  | 2 | 7-3/4    | 29-1/2   | 30-1/2    | 1-3/16  | 1-7/16   | 1-11/16   |
| 165  | 18-1/16  | 12-5/8   | 21-3/16  | 32-5/8   | 17 | 34-3/8  | 19-15/16 | 2 | 8-5/16   | 30-5/8   | 32-5/8    | 1-3/16  | 1-7/16   | 1-11/16   |
| 180  | 19-11/16 | 13-3/4   | 22-11/16 | 35-1/8   | 18 | 37-1/8  | 21-9/16  | 2 | 8-7/8    | 33-3/4   | 36-1/4    | 1-7/16  | 1-11/16  | 1-11/16   |
| 195  | 21-5/16  | 14-15/16 | 24-3/16  | 38-1/2   | 20 | 40      | 23-3/16  | 2 | 9-1/2    | 35       | 37-1/2    | 1-7/16  | 1-11/16  | 1-11/16   |
| 210  | 23       | 16-1/16  | 25-15/16 | 40-15/16 | 21 | 42-7/8  | 24-7/8   | 2 | 10-1/16  | 38-1/8   | 41-1/8    | 1-7/16  | 1-11/16  | 1-15/16   |
| 225  | 24-5/8   | 17-3/16  | 27-7/16  | 44-3/8   | 23 | 45-3/4  | 26-1/2   | 2 | 10-5/8   | 39-1/4   | 42-1/4    | 1-7/16  | 1-11/16  | 1-15/16   |
| 245  | 26-13/16 | 18-3/4   | 29-7/16  | 48-1/4   | 25 | 49-1/2  | 28-5/8   | 2 | 11-3/8   | 42-3/4   | 46-1/4    | 1-11/16 | 1-15/16  | 2-3/16    |
| 270  | 29-9/16  | 20-5/8   | 31-15/16 | 50-1/8   | 27 | 54-3/4  | 31-3/8   | 2 | 12-5/16  | 44-5/8   | 48-5/8    | 1-11/16 | 1-15/16  | 2-3/16    |
| 300  | 32-13/16 | 22-15/16 | 34-15/16 | 58-1/2   | 30 | 60      | 34-5/8   | 2 | 13-1/2   | 49       | 53-1/2    | 1-15/16 | 2-3/16   | 2-7/16    |
| 330  | 36-1/8   | 25-1/4   | 37-15/16 | 64-3/8   | 33 | 65-3/4  | 37-7/8   | 2 | 14-5/8   | 51-1/4   | 56-1/4    | 1-15/16 | 2-3/16   | 2-7/16    |
| 365  | 39-15/16 | 27-7/8   | 41-7/16  | 70-5/8   | 36 | 72-3/8  | 41-3/4   | 2 | 15-15/16 | 57-3/4   | 63-1/4    | 2-3/16  | 2-7/16   | 2-15/16   |
| 402  | 44-1/16  | 30-3/4   | 45-3/16  | 78-1/4   | 40 | 80-3/8  | 46-3/4   | 3 | 18-3/8   | 62-11/16 | 67-11/16  | 2-3/16  | 2-7/16   | 2-15/16   |
| 445  | 48-11/16 | 34       | 49-7/16  | 86-1/4   | 44 | 88-1/2  | 51-3/8   | 3 | 20       | 69-15/16 | 75-7/16   | 2-7/16  | 2-15/16  | 3-7/16    |
| 490  | 53-5/8   | 37-7/16  | 55       | 94-1/2   | 48 | 97      | 56-1/4   | 3 | 21-3/4   | 73-7/16  | 79-7/16   | 2-7/16  | 2-15/16  | 3-7/16    |
| 540  | 59-1/16  | 41-1/4   | 60       | 104-1/4  | 53 | 106-5/8 | 61-3/4   | 3 | 23-5/8   | 81-3/16  | 87-11/16  | 2-15/16 | 3-7/16   | 3-15/16   |
| 600  | 65-5/8   | 45-13/16 | 66       | 116      | 59 | 118     | 68-1/4   | 3 | 25-15/16 | 85-11/16 | 92-11/16  | 2-15/16 | 3-7/16   | 3-15/16   |
| 660  | 72-3/16  | 50-7/16  | 72       | 121-5/8  | 65 | 129-3/8 | 74-3/4   | 3 | 28-1/4   | 94-7/16  | 101-15/16 | 3-7/16  | 3-15/16  | 4-7/16    |
| 730  | 79-7/8   | 55-3/4   | 79       | 141-5/16 | 72 | 142-5/8 | 82-3/8   | 3 | 30-7/8   | 99-11/16 | 107-11/16 | 3-7/16  | 3-15/16  | 4-7/16    |

| Size | P      | R  | S  | T      | U       | V       | W        | X      | Y      | Max Mtr Frame | Ship Wt ** |
|------|--------|----|----|--------|---------|---------|----------|--------|--------|---------------|------------|
| 120  | 18-3/8 | -  | 15 | 3-3/16 | 5-3/4   | 12-1/8  | 8-7/16   | 9-3/4  | 11/16  | 145T          | 211        |
| 135  | 19-7/8 | -  | 17 | 3-9/16 | 6-5/16  | 12-1/8  | 9-3/16   | 9-3/4  | 11/16  | 145T          | 266        |
| 150  | 21-3/8 | -  | 18 | 4-5/16 | 6-7/8   | 14-1/8  | 9-15/16  | 11-3/4 | 11/16  | 184T          | 325        |
| 165  | 23-3/8 | -  | 20 | 4-7/16 | 7-7/16  | 14-1/8  | 10-15/16 | 11-3/4 | 11/16  | 184T          | 387        |
| 180  | 24-7/8 | -  | 22 | 4-9/16 | 8       | 16-1/8  | 11-11/16 | 13-3/4 | 11/16  | 215T          | 453        |
| 195  | 26-3/8 | 9  | 23 | 5-5/16 | 8-5/8   | 16-1/8  | 12-7/16  | 13-3/4 | 11/16  | 215T          | 523        |
| 210  | 28-1/8 | 10 | 24 | 6      | 9-3/16  | 18-1/8  | 13-5/16  | 15-3/4 | 13/16  | 254T          | 599        |
| 225  | 29-5/8 | 10 | 25 | 6-3/4  | 9-3/4   | 18-1/8  | 14-1/16  | 15-3/4 | 13/16  | 254T          | 677        |
| 245  | 31-5/8 | 11 | 27 | 7-3/8  | 10-1/2  | 20-1/8  | 15-1/16  | 17-3/4 | 13/16  | 284T          | 786        |
| 270  | 34-3/8 | 12 | 30 | 8-3/8  | 11-7/16 | 20-1/8  | 16-7/16  | 17-3/4 | 13/16  | 284T          | 931        |
| 300  | 37-3/8 | 14 | 33 | 8-7/8  | 12-5/8  | 22-1/8  | 17-15/16 | 19-3/4 | 13/16  | 324T          | 1118       |
| 330  | 40-3/8 | 16 | 36 | 9-7/8  | 13-3/4  | 22-1/8  | 19-7/16  | 19-3/4 | 13/16  | 324T          | 1320       |
| 365  | 44-7/8 | 17 | 40 | 10-5/8 | 15-1/16 | 26      | 21-11/16 | 23-3/4 | 13/16  | 326T          | 1575       |
| 402  | 48-3/4 | 20 | 44 | 11-5/8 | 17-1/8  | 26-3/16 | 23-3/8   | 23-3/4 | 1-1/16 | 326T          | 1858       |
| 445  | 53     | 23 | 48 | 13-1/8 | 18-3/4  | 30-3/16 | 25-1/2   | 27-3/4 | 1-1/16 | 326T          | 2223       |
| 490  | 58-1/2 | 26 | 53 | 14-1/4 | 20-1/2  | 30-3/16 | 28-1/4   | 27-3/4 | 1-1/16 | 404T          | 2636       |
| 540  | 63-1/2 | 29 | 58 | 15-7/8 | 22-3/8  | 34-3/16 | 30-3/4   | 31-3/4 | 1-1/16 | 404T          | 3190       |
| 600  | 69-1/2 | 32 | 64 | 17-3/4 | 24-5/8  | 34-3/16 | 33-3/4   | 31-3/4 | 1-1/16 | 404T          | 3852       |
| 660  | 75-1/2 | 36 | 70 | 19-5/8 | 27      | 38-3/16 | 36-3/4   | 35-3/4 | 1-1/16 | 404T          | 4576       |
| 730  | 82-1/2 | 40 | 77 | 21-3/4 | 29-5/8  | 38-3/16 | 40-1/4   | 35-3/4 | 1-1/16 | 404T          | 5495       |

ALL DIMENSIONS IN INCHES. WEIGHTS IN LBS., LESS MOTOR. MAXIMUM MOTOR FRAME BASED ON SINGLE SPEED ODP MOTORS.  
 \*\* BASED ON CLASS I CONSTRUCTION.

CF008R02