



# COOK

# CF SWSI

DATE: \_\_\_\_\_  
 PROJECT: \_\_\_\_\_  
 LOCATION: \_\_\_\_\_



**Flat Blade Centrifugal Blower**  
**Counterclockwise Bottom Horizontal**  
**Arrangement 1\* & 9**

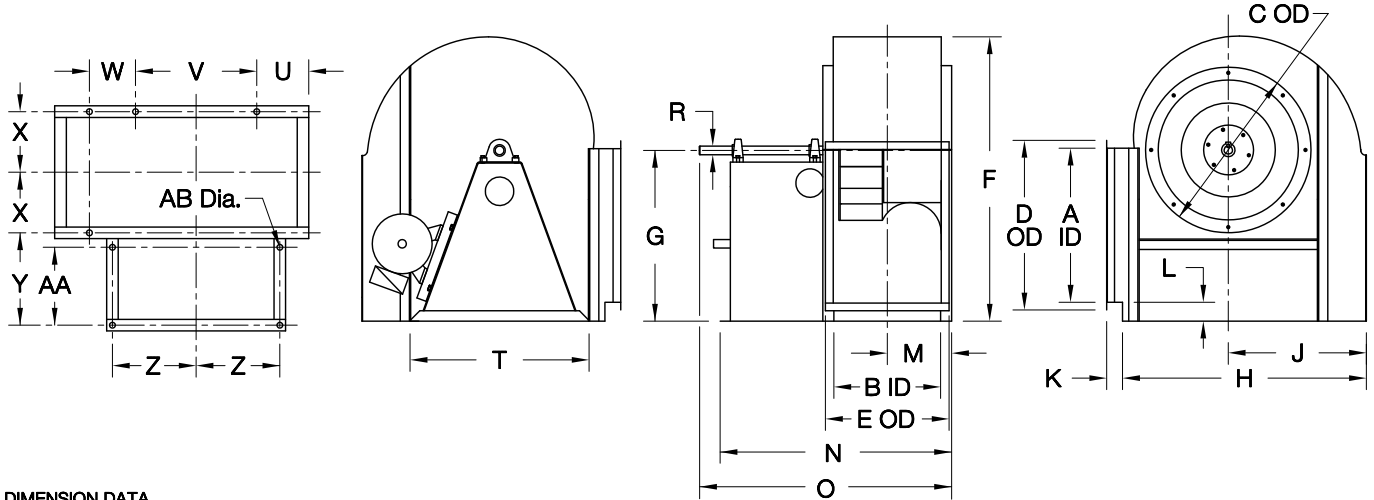

**DIMENSION DATA**

Size	A	B	C	D	E	F	G	H	J	K	L	M	N	O
120	13-1/8	9-3/16	16-1/8	16-5/16	12-3/8	25-3/4	16	21-1/2	12-3/8	3-1/4	2-15/16	6-5/8	25-1/4	26-1/4
135	14-3/4	10-5/16	17-5/8	17-5/16	13-1/2	28	17	24	13-7/8	3-1/4	2-5/16	7-3/16	26-3/8	27-3/8
150	16-7/16	11-7/16	19-1/8	19-5/8	14-5/8	31-3/16	19	26	15-3/16	3-1/4	2-11/16	7-3/4	29-1/2	30-1/2
165	18-1/16	12-5/8	21-3/16	21-1/4	15-13/16	34-3/8	21	28-1/2	16-5/8	3-1/4	3-1/16	8-5/16	30-5/8	32-5/8
180	19-11/16	13-3/4	22-11/16	22-7/8	16-15/16	36-5/8	22	30-3/4	18-1/8	3-1/4	2-7/16	8-7/8	33-3/4	36-1/4
195	21-5/16	14-15/16	24-3/16	24-1/2	18-3/16	39-13/16	24	33	19-7/16	3-1/2	2-13/16	9-1/2	35	37-1/2
210	23	16-1/16	25-15/16	26-3/16	19-5/16	43-1/16	26	38	21	3-1/4	3-1/8	10-1/16	38-1/8	41-1/8
225	24-5/8	17-3/16	27-7/16	27-13/16	20-7/16	46-1/4	28	40	22-3/8	3-1/4	3-1/2	10-5/8	39-1/4	42-1/4
245	26-13/16	18-3/4	29-7/16	30	22	49-7/8	30	43	24-1/4	3-1/4	3-3/8	11-3/8	42-3/4	46-1/4
270	29-9/16	20-5/8	31-15/16	32-3/4	23-7/8	54-15/16	33	47	26-5/8	3-1/4	3-5/8	12-5/16	44-5/8	48-5/8
300	32-13/16	22-15/16	34-15/16	36	26-3/16	60-3/8	36	52	29-1/2	3-5/8	3-3/8	13-1/2	49	53-1/2
330	36-1/8	25-1/4	37-15/16	40-5/16	29-7/16	65-13/16	39	57	32-5/16	4	3-1/8	14-5/8	51-1/4	56-1/4
365	39-15/16	27-7/8	41-7/16	44-3/16	32-1/16	72-5/8	43	63	35-9/16	4-1/4	3-1/4	15-15/16	57-3/4	63-1/4
402	44-1/16	30-3/4	45-3/16	48-5/16	34-15/16	79-5/8	47	69	39-3/16	5-1/8	3-1/4	18-3/8	62-11/16	67-11/16
445	48-11/16	34	49-7/16	52-15/16	38-3/16	88-1/8	52	77	43-3/16	4-3/4	3-5/8	20	69-15/16	75-7/16
490	53-5/8	37-7/16	55	57-7/8	41-5/8	96-3/4	57	85	47-9/16	5	3-3/4	21-3/4	73-7/16	79-7/16
540	59-1/16	41-1/4	60	63-5/16	45-7/16	105-13/16	62	94	52-1/4	5	3-1/4	23-5/8	81-3/16	87-11/16
600	65-5/8	45-13/16	66	70	50-3/16	117-11/16	69	105	57-15/16	4-7/8	3-3/4	25-15/16	85-11/16	92-11/16
660	72-3/16	50-7/16	72	76-9/16	54-13/16	128-9/16	75	116	63-3/4	4-7/8	3-1/4	28-1/4	94-7/16	101-15/16
730	79-7/8	55-3/4	79	84-1/4	60-1/8	142-1/4	83	129	70-3/8	4-1/2	3-5/8	30-7/8	99-11/16	107-11/16

Size	R			T	U	V	W	X	Y	Z	AA	AB	Max Mtr Frame	Ship Wt **
	Class I	Class II	Class III											
120	1-3/16	1-7/16	1-11/16	18-3/8	1-5/8	15	-	5-3/4	12-1/8	8-7/16	9-3/4	11/16	145T	211
135	1-3/16	1-7/16	1-11/16	19-7/8	1-5/8	17	-	6-5/16	12-1/8	9-3/16	9-3/4	11/16	145T	266
150	1-3/16	1-7/16	1-11/16	21-3/8	1-13/16	18	-	6-7/8	14-1/8	9-15/16	11-3/4	11/16	184T	325
165	1-3/16	1-7/16	1-11/16	23-3/8	1-7/8	20	-	7-7/16	14-1/8	10-15/16	11-3/4	11/16	184T	387
180	1-7/16	1-11/16	1-11/16	24-7/8	1-5/8	22	-	8	16-1/8	11-11/16	13-3/4	11/16	215T	453
195	1-7/16	1-11/16	1-11/16	26-3/8	2-1/16	23	6	8-5/8	16-1/8	12-7/16	13-3/4	11/16	215T	523
210	1-7/16	1-11/16	1-15/16	28-1/8	5	24	7	9-3/16	18-1/8	13-5/16	15-3/4	13/16	254T	599
225	1-7/16	1-11/16	1-15/16	29-5/8	5-1/8	25	7-1/2	9-3/4	18-1/8	14-1/16	15-3/4	13/16	254T	677
245	1-11/16	1-15/16	2-3/16	31-5/8	5-1/4	27	8	10-1/2	20-1/8	15-1/16	17-3/4	13/16	284T	786
270	1-11/16	1-15/16	2-3/16	34-3/8	5-3/8	30	9	11-7/16	20-1/8	16-7/16	17-3/4	13/16	284T	931
300	1-15/16	2-3/16	2-7/16	37-3/8	6	33	10	12-5/8	22-1/8	17-15/16	19-3/4	13/16	324T	1118
330	1-15/16	2-3/16	2-7/16	40-3/8	6-11/16	36	12	13-3/4	22-1/8	19-7/16	19-3/4	13/16	324T	1320
365	2-3/16	2-7/16	2-15/16	44-7/8	7-7/16	40	13	15-1/16	26	21-11/16	23-3/4	13/16	326T	1575
402	2-3/16	2-7/16	2-15/16	48-3/4	7-13/16	44	14	17-1/8	26-3/16	23-3/8	23-3/4	1-1/16	326T	1858
445	2-7/16	2-15/16	3-7/16	53	9-13/16	48	16	18-3/4	30-3/16	25-1/2	27-3/4	1-1/16	326T	2223
490	2-7/16	2-15/16	3-7/16	58-1/2	10-15/16	53	18	20-1/2	30-3/16	28-1/4	27-3/4	1-1/16	404T	2636
540	2-15/16	3-7/16	3-15/16	63-1/2	12-3/4	58	20	22-3/8	34-3/16	30-3/4	31-3/4	1-1/16	404T	3190
600	2-15/16	3-7/16	3-15/16	69-1/2	15-1/16	64	22	24-5/8	34-3/16	33-3/4	31-3/4	1-1/16	404T	3852
660	3-7/16	3-15/16	4-7/16	75-1/2	17-1/4	70	25	27	38-3/16	36-3/4	35-3/4	1-1/16	404T	4576
730	3-7/16	3-15/16	4-7/16	82-1/2	20-1/8	77	28	29-5/8	38-3/16	40-1/4	35-3/4	1-1/16	404T	5495

ALL DIMENSIONS IN INCHES. WEIGHTS IN LBS., LESS MOTOR. MAXIMUM MOTOR FRAME BASED ON SINGLE SPEED ODP MOTORS (ARR. 9 ONLY).  
 \* ARRANGEMENT 9 SHOWN. ARRANGEMENT 1 SIMILAR BUT WITHOUT MOTOR MOUNTING PROVISION. \*\* BASED ON CLASS I CONSTRUCTION.

CF015R02