



COOK

CF SWSI

DATE: _____
 PROJECT: _____
 LOCATION: _____



**Flat Blade Centrifugal Blower
 Clockwise Bottom Angular Up
 Arrangement 1* & 9**

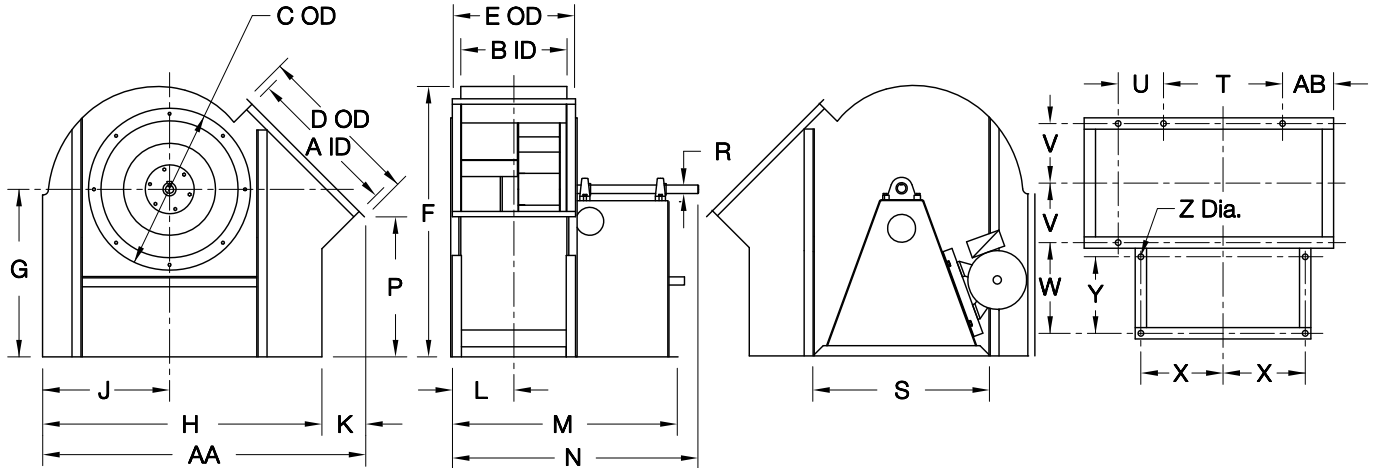

DIMENSION DATA

Size	A	B	C	D	E	F	G	H	J	K	L	M	N	P
120	13-1/8	9-3/16	16-1/8	16-5/16	12-3/8	25-1/16	16	26	12	3-3/4	6-5/8	25-1/4	26-1/4	13
135	14-3/4	10-5/16	17-5/8	17-5/16	13-1/2	27-3/16	17	29	13	3-3/4	7-3/16	26-3/8	27-3/8	13-11/16
150	16-7/16	11-7/16	19-1/8	19-5/8	14-5/8	30-5/16	19	32	14	3-13/16	7-3/4	29-1/2	30-1/2	15-1/2
165	18-1/16	12-5/8	21-3/16	21-1/4	15-13/16	33-7/16	21	35	16	4-7/8	8-5/16	30-5/8	32-5/8	17-1/4
180	19-11/16	13-3/4	22-11/16	22-7/8	16-15/16	35-1/2	22	37	17	5-15/16	8-7/8	33-3/4	36-1/4	18
195	21-5/16	14-15/16	24-3/16	24-1/2	18-3/16	38-5/8	24	40	18	6	9-1/2	35	37-1/2	19-3/4
210	23	16-1/16	25-15/16	26-3/16	19-5/16	41-3/4	26	44	20	6-1/8	10-1/16	38-1/8	41-1/8	21-1/2
225	24-5/8	17-3/16	27-7/16	27-13/16	20-7/16	44-7/8	28	46	21	7-3/16	10-5/8	39-1/4	42-1/4	23-1/4
245	26-13/16	18-3/4	29-7/16	30	22	48-3/8	30	50	23	7-15/16	11-3/8	42-3/4	46-1/4	25
270	29-9/16	20-5/8	31-15/16	32-3/4	23-7/8	53-1/4	33	55	25	8-5/16	12-5/16	44-5/8	48-5/8	27-9/16
300	32-13/16	22-15/16	34-15/16	36	26-3/16	58-7/16	36	61	28	9-1/2	13-1/2	49	53-1/2	30-1/16
330	36-1/8	25-1/4	37-15/16	40-5/16	29-7/16	63-11/16	39	68	31	9-15/16	14-5/8	51-1/4	56-1/4	32-1/4
365	39-15/16	27-7/8	41-7/16	44-3/16	32-1/16	70-5/16	43	74	34	11-13/16	15-15/16	57-3/4	63-1/4	35-5/8
402	44-1/16	30-3/4	45-3/16	48-5/16	34-15/16	77-1/8	47	80	37	14	18-3/8	62-11/16	67-11/16	39-1/16
445	48-11/16	34	49-7/16	52-15/16	38-3/16	85-1/4	52	89	41	14-13/16	20	69-15/16	75-7/16	43-3/8
490	53-5/8	37-7/16	55	57-7/8	41-5/8	93-5/8	57	98	45	16	21-3/4	73-7/16	79-7/16	47-11/16
540	59-1/16	41-1/4	60	63-5/16	45-7/16	102-5/16	62	106	49	18-15/16	23-5/8	81-3/16	87-11/16	51-13/16
600	65-5/8	45-13/16	66	70	50-3/16	113-13/16	69	118	54	20-1/4	25-15/16	85-11/16	92-11/16	57-7/8
660	72-3/16	50-7/16	72	76-9/16	54-13/16	124-1/4	75	130	60	22-7/16	28-1/4	94-7/16	101-15/16	63
730	79-7/8	55-3/4	79	84-1/4	60-1/8	137-1/2	83	143	66	25-1/8	30-7/8	99-11/16	107-11/16	69-13/16

Size	R			S	T	U	V	W	X	Y	Z	AA	AB	Max Mtr Frame	Ship Wt **
	Class I	Class II	Class III												
120	1-3/16	1-7/16	1-11/16	18-3/8	15	-	5-3/4	12-1/8	8-7/16	9-3/4	11/16	29-7/8	4-1/2	145T	211
135	1-3/16	1-7/16	1-11/16	19-7/8	17	-	6-5/16	12-1/8	9-3/16	9-3/4	11/16	32-15/16	4-1/2	145T	266
150	1-3/16	1-7/16	1-11/16	21-3/8	18	-	6-7/8	14-1/8	9-15/16	11-3/4	11/16	36	5	184T	325
165	1-3/16	1-7/16	1-11/16	23-3/8	20	-	7-7/16	14-1/8	10-15/16	11-3/4	11/16	40-1/16	6	184T	387
180	1-7/16	1-11/16	1-11/16	24-7/8	22	-	8	16-1/8	11-11/16	13-3/4	11/16	43-1/8	6	215T	453
195	1-7/16	1-11/16	1-11/16	26-3/8	23	7-1/2	8-5/8	16-1/8	12-7/16	13-3/4	11/16	46-5/16	6-1/2	215T	523
210	1-7/16	1-11/16	1-15/16	28-1/8	24	9	9-3/16	18-1/8	13-5/16	15-3/4	13/16	50-1/4	8	254T	599
225	1-7/16	1-11/16	1-15/16	29-5/8	25	9-1/2	9-3/4	18-1/8	14-1/16	15-3/4	13/16	53-5/16	8-1/2	254T	677
245	1-11/16	1-15/16	2-3/16	31-5/8	27	10-1/2	10-1/2	20-1/8	15-1/16	17-3/4	13/16	58-1/8	9-1/2	284T	786
270	1-11/16	1-15/16	2-3/16	34-3/8	30	12	11-7/16	20-1/8	16-7/16	17-3/4	13/16	63-1/2	10	284T	931
300	1-15/16	2-3/16	2-7/16	37-3/8	33	13-1/2	12-5/8	22-1/8	17-15/16	19-3/4	13/16	70-11/16	11-1/2	324T	1118
330	1-15/16	2-3/16	2-7/16	40-3/8	36	15	13-3/4	22-1/8	19-7/16	19-3/4	13/16	78-1/8	13	324T	1320
365	2-3/16	2-7/16	2-15/16	44-7/8	40	16	15-1/16	26	21-11/16	23-3/4	13/16	86-1/16	14	326T	1575
402	2-3/16	2-7/16	2-15/16	48-3/8	44	17	17-1/8	26-3/16	23-3/8	23-3/4	1-1/16	94-1/8	15	326T	1858
445	2-7/16	2-15/16	3-7/16	53	48	20	18-3/4	30-3/16	25-1/2	27-3/4	1-1/16	104-3/8	17	326T	2223
490	2-7/16	2-15/16	3-7/16	58-1/2	53	22-1/2	20-1/2	30-3/16	28-1/4	27-3/4	1-1/16	114-3/16	18-1/2	404T	2636
540	2-15/16	3-7/16	3-15/16	63-1/2	58	24	22-3/8	34-3/16	30-3/4	31-3/4	1-1/16	125	20	404T	3190
600	2-15/16	3-7/16	3-15/16	69-1/2	64	28	24-5/8	34-3/16	33-3/4	31-3/4	1-1/16	138-5/16	22	404T	3852
660	3-7/16	3-15/16	4-7/16	75-1/2	70	31	27	38-3/16	36-3/4	35-3/4	1-1/16	152-5/8	25	404T	4576
730	3-7/16	3-15/16	4-7/16	82-1/2	77	34-1/2	29-5/8	38-3/16	40-1/4	35-3/4	1-1/16	169-3/16	27-1/2	404T	5495

ALL DIMENSIONS IN INCHES. WEIGHTS IN LBS., LESS MOTOR. MAXIMUM MOTOR FRAME BASED ON SINGLE SPEED ODP MOTORS (ARR. 9 ONLY).
 * ARRANGEMENT 9 SHOWN. ARRANGEMENT 1 SIMILAR BUT WITHOUT MOTOR MOUNTING PROVISION. ** BASED ON CLASS I CONSTRUCTION.