



COOK

CF SWSI

DATE: _____
 PROJECT: _____
 LOCATION: _____



Flat Blade Centrifugal Blower
Counterclockwise Top Angular Down
Arrangement 1* & 9

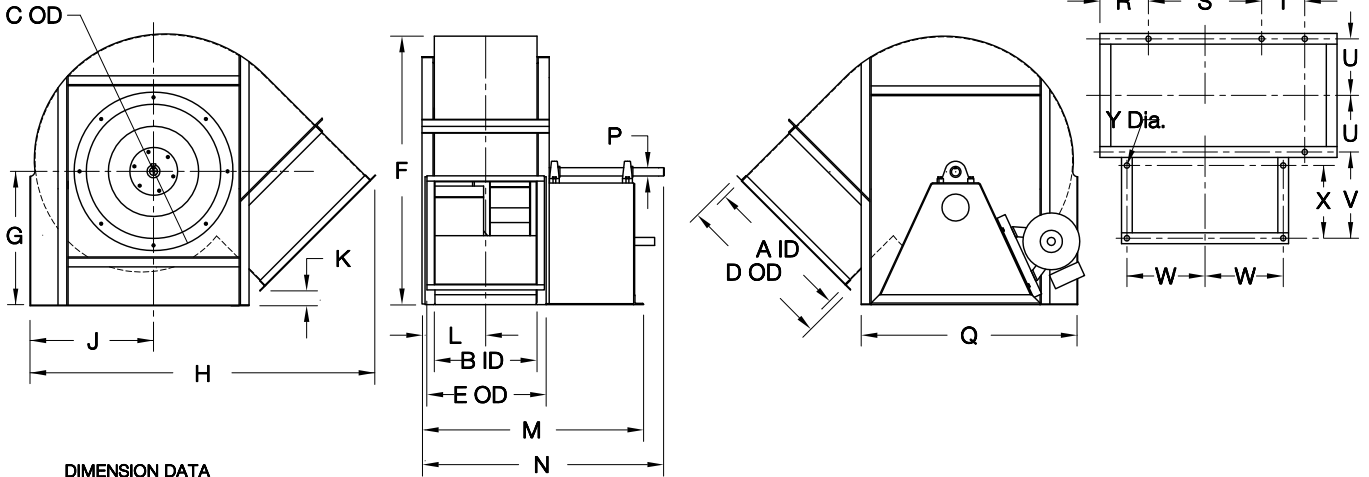

DIMENSION DATA

Size	A	B	C	D	E	F	G	H	J	K	L	M	N
120	13-1/8	9-3/16	16-1/8	16-5/16	12-3/8	25-5/16	13	33-3/8	11-5/8	9/16	6-5/8	25-1/4	26-1/4
135	14-3/4	10-5/16	17-5/8	17-15/16	13-1/2	27-7/8	14	36-5/16	12-15/16	1	7-3/16	26-3/8	27-3/8
150	16-7/16	11-7/16	19-1/8	19-5/8	14-5/8	30-3/8	15	39-7/8	14-5/16	13/16	7-3/4	29-1/2	30-1/2
165	18-1/16	12-5/8	21-3/16	21-1/4	15-13/16	33-7/8	17	43-1/2	15-5/8	1-1/8	8-5/16	30-5/8	32-5/8
180	19-11/16	13-3/4	22-11/16	22-7/8	16-15/16	36-7/16	18	46-7/16	16-15/16	2-1/4	8-7/8	33-3/4	36-1/4
195	21-5/16	14-15/16	24-3/16	24-1/2	18-3/16	39-15/16	20	51-1/2	18-1/4	1-11/16	9-1/2	35	37-1/2
210	23	16-1/16	25-15/16	26-3/16	19-5/16	42-3/8	21	54-3/4	19-9/16	1-7/8	10-1/16	38-1/8	41-1/8
225	24-5/8	17-3/16	27-7/16	27-13/16	20-7/16	45-15/16	23	58-3/8	20-7/8	2-11/16	10-5/8	39-1/4	42-1/4
245	26-13/16	18-3/4	29-7/16	30	22	49-15/16	25	63-3/16	22-11/16	3-3/16	11-3/8	42-3/4	46-1/4
270	29-9/16	20-5/8	31-15/16	32-3/4	23-7/8	54-5/8	27	68-1/8	24-7/8	4-5/16	12-5/16	44-5/8	48-5/8
300	32-13/16	22-15/16	34-15/16	36	26-3/16	60-9/16	30	74-11/16	27-1/2	5-3/4	13-1/2	49	53-1/2
330	36-1/8	25-1/4	37-15/16	40-5/16	29-7/16	66-11/16	33	82-1/4	30-1/8	6-1/16	14-5/8	51-1/4	56-1/4
365	39-15/16	27-7/8	41-7/16	44-3/16	32-1/16	73-5/16	36	89-5/8	33-3/16	7-7/16	15-15/16	57-3/4	63-1/4
402	44-1/16	30-3/4	45-3/16	48-5/16	34-15/16	81-1/8	40	99-9/16	36-1/2	7-11/16	18-3/8	62-11/16	67-11/16
445	48-11/16	34	49-7/16	52-15/16	38-3/16	89-5/16	44	108-1/4	40-1/4	10	20	69-15/16	75-7/16
490	53-5/8	37-7/16	55	57-7/8	41-5/8	97-7/8	48	118-11/16	44-3/16	10-7/8	21-3/4	73-7/16	79-7/16
540	59-1/16	41-1/4	60	63-5/16	45-7/16	108	53	131-1/2	48-9/16	11-3/8	23-5/8	81-3/16	87-11/16
600	65-5/8	45-13/16	66	70	50-3/16	120-1/16	59	143-1/8	53-13/16	15-5/8	25-15/16	85-11/16	92-11/16
660	72-3/16	50-7/16	72	76-9/16	54-13/16	132-3/16	65	159	59-1/8	15-9/16	28-1/4	94-7/16	101-15/16
730	79-7/8	55-3/4	79	84-1/4	60-1/8	146-7/16	72	173	65-1/4	20	30-7/8	99-11/16	107-11/16

Size	P			Q	R	S	T	U	V	W	X	Y	Max Mtr Frame	Ship Wt **
	Class I	Class II	Class III											
120	1-3/16	1-7/16	1-11/16	20-13/16	1-11/16	15	-	5-3/4	12-1/8	8-7/16	9-3/4	11/16	145T	211
135	1-3/16	1-7/16	1-11/16	22-7/8	1-7/16	17	-	6-5/16	12-1/8	9-3/16	9-3/4	11/16	145T	266
150	1-3/16	1-7/16	1-11/16	25	1-11/16	18	-	6-7/8	14-1/8	9-15/16	11-3/4	11/16	184T	325
165	1-3/16	1-7/16	1-11/16	27-5/16	1-11/16	20	-	7-7/16	14-1/8	10-15/16	11-3/4	11/16	184T	387
180	1-7/16	1-11/16	1-11/16	29-3/8	1-7/16	22	-	8	16-1/8	11-11/16	13-3/4	11/16	215T	453
195	1-7/16	1-11/16	1-11/16	33-7/16	3-11/16	23	5	8-5/8	16-1/8	12-7/16	13-3/4	11/16	215T	523
210	1-7/16	1-11/16	1-15/16	35-5/8	4-1/16	24	5-1/2	9-3/16	18-1/8	13-5/16	15-3/4	13/16	254T	599
225	1-7/16	1-11/16	1-15/16	37-11/16	4-5/16	25	5-3/4	9-3/4	18-1/8	14-1/16	15-3/4	13/16	254T	677
245	1-11/16	1-15/16	2-3/16	40-1/2	4-5/16	27	6	10-1/2	20-1/8	15-1/16	17-3/4	13/16	284T	786
270	1-11/16	1-15/16	2-3/16	44-1/16	4-3/16	30	6-1/2	11-7/16	20-1/8	16-7/16	17-3/4	13/16	284T	931
300	1-15/16	2-3/16	2-7/16	48-3/16	4-3/16	33	7	12-5/8	22-1/8	17-15/16	19-3/4	13/16	324T	1118
330	1-15/16	2-3/16	2-7/16	52-5/16	4-3/16	36	8	13-3/4	22-1/8	19-7/16	19-3/4	13/16	324T	1320
365	2-3/16	2-7/16	2-15/16	57-5/8	4-7/16	40	8-1/2	15-1/16	26	21-11/16	23-3/4	13/16	326T	1575
402	2-3/16	2-7/16	2-15/16	63-3/8	4-7/8	44	9	17-1/8	26-3/16	23-3/8	23-3/4	1-1/16	326T	1858
445	2-7/16	2-15/16	3-7/16	69-1/4	5	48	9-1/2	18-3/4	30-3/16	25-1/2	27-3/4	1-1/16	326T	2223
490	2-7/16	2-15/16	3-7/16	75-15/16	5-1/4	53	11	20-1/2	30-3/16	28-1/4	27-3/4	1-1/16	404T	2636
540	2-15/16	3-7/16	3-15/16	82-13/16	5-1/4	58	13	22-3/8	34-3/16	30-3/4	31-3/4	1-1/16	404T	3190
600	2-15/16	3-7/16	3-15/16	91-9/16	5-3/4	64	15	24-5/8	34-3/16	33-3/4	31-3/4	1-1/16	404T	3852
660	3-7/16	3-15/16	4-7/16	99-7/8	5-3/4	70	17	27	38-3/16	36-3/4	35-3/4	1-1/16	404T	4576
730	3-7/16	3-15/16	4-7/16	109-1/2	5-3/4	77	20	29-5/8	38-3/16	40-1/4	35-3/4	1-1/16	404T	5495

ALL DIMENSIONS IN INCHES. WEIGHTS IN LBS., LESS MOTOR. MAXIMUM MOTOR FRAME BASED ON SINGLE SPEED ODP MOTORS (ARR. 9 ONLY).
 * ARRANGEMENT 9 SHOWN. ARRANGEMENT 1 SIMILAR BUT WITHOUT MOTOR MOUNTING PROVISION. ** BASED ON CLASS I CONSTRUCTION.

CF027R03