



COOK

CF SWSI

DATE: _____
 PROJECT: _____
 LOCATION: _____



Flat Blade Centrifugal Blower
Counterclockwise Top Horizontal
Arrangement 3

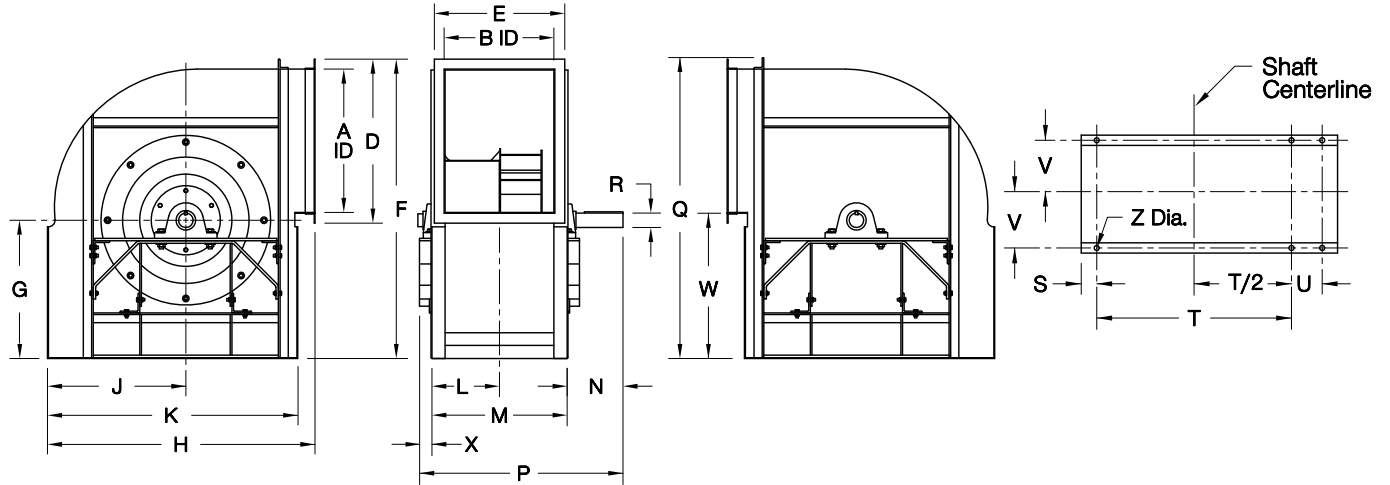

DIMENSION DATA

Size	A	B	D	E	F	G	H	J	K	L	M	N
120	13-1/8	9-3/16	16-5/16	12-3/8	27-11/16	13	24-1/2	12-3/8	21-1/2	6-5/8	13-3/16	4-5/8
135	14-3/4	10-5/16	17-15/16	13-1/2	30-5/16	14	27	13-7/8	24	7-3/16	14-5/16	4-5/8
150	16-7/16	11-7/16	19-5/8	14-5/8	32-15/16	15	29	15-3/16	26	7-3/4	15-7/16	4-5/8
165	18-1/16	12-5/8	21-1/4	15-13/16	36-9/16	17	31-1/2	16-5/8	28-1/2	8-5/16	16-5/8	5-5/8
180	19-11/16	13-3/4	22-7/8	16-15/16	39-1/4	18	33-3/4	18-1/8	30-3/4	8-7/8	17-3/4	6-1/8
195	21-5/16	14-15/16	24-1/2	18-3/16	42-7/8	20	36-1/4	19-7/16	33	9-1/2	18-15/16	6-1/8
210	23	16-1/16	26-3/16	19-5/16	45-9/16	21	41	21	38	10-1/16	20-1/16	6-5/8
225	24-5/8	17-3/16	27-13/16	20-7/16	49-1/8	23	43	22-3/8	40	10-5/8	21-3/16	6-5/8
245	26-13/16	18-3/4	30	22	53-1/4	25	46	24-1/4	43	11-3/8	22-3/4	7-5/8
270	29-9/16	20-5/8	32-3/4	23-7/8	58	27	50	26-5/8	47	12-5/16	24-5/8	8-1/8
300	32-13/16	22-15/16	36	26-3/16	64-1/4	30	55-3/8	29-1/2	52	13-1/2	26-15/16	8-5/8
330	36-1/8	25-1/4	40-5/16	29-7/16	71	33	60-3/4	32-5/16	57	14-5/8	29-1/4	9-1/8
365	39-15/16	27-7/8	44-3/16	32-1/16	77-7/8	36	67	35-9/16	63	15-15/16	31-7/8	9-5/8
402	44-1/16	30-3/4	48-5/16	34-15/16	85-15/16	40	73-7/8	39-3/16	69	18-3/8	36-3/4	9-3/16
445	48-11/16	34	52-15/16	38-3/16	94-1/2	44	81-1/2	43-3/16	77	20	40	9-11/16
490	53-5/8	37-7/16	57-7/8	41-5/8	103-3/8	48	89-3/4	47-9/16	85	21-3/4	43-7/16	10-11/16
540	59-1/16	41-1/4	63-5/16	45-7/16	113-15/16	53	98-3/4	52-1/4	94	23-5/8	47-1/4	12-3/16
600	65-5/8	45-13/16	70	50-3/16	126-3/8	59	109-5/8	57-15/16	105	25-15/16	51-13/16	12-3/4
660	72-3/16	50-7/16	76-9/16	54-13/16	138-15/16	65	120-5/8	64-3/4	116	28-1/4	56-7/16	14-1/4
730	79-7/8	55-3/4	84-1/4	60-1/8	153-1/2	72	133-1/4	70-3/8	129	30-7/8	61-3/4	14-3/4

Size	P	Q	R			S	T	U	V	W	X	Z	Ship Wt. *
			Class I	Class II	Class III								
120	19-7/16	-	1	1	1-3/16	1-5/8	15	-	5-3/4	12-15/16	1-5/8	11/16	157
135	20-9/16	-	1	1	1-3/16	1-5/8	17	-	6-5/16	13-15/16	1-5/8	11/16	195
150	21-11/16	-	1	1-3/16	1-7/16	1-13/16	18	-	6-7/8	14-7/8	1-5/8	11/16	236
165	23-7/8	-	1	1-3/16	1-7/16	1-7/8	20	-	7-7/16	16-7/8	1-5/8	11/16	280
180	25-1/2	-	1-3/16	1-7/16	1-11/16	1-5/8	22	-	8	17-7/8	1-5/8	11/16	328
195	26-11/16	-	1-7/16	1-7/16	1-11/16	2-1/16	23	6	8-5/8	19-7/8	1-5/8	11/16	379
210	28-5/16	46-1/16	1-7/16	1-7/16	1-11/16	5	24	7	9-3/16	20-7/8	1-5/8	13/16	437
225	29-7/16	49-5/8	1-7/16	1-7/16	1-11/16	5-1/8	25	7-1/2	9-3/4	22-7/8	1-5/8	13/16	496
245	32-1/2	53-3/4	1-7/16	1-11/16	1-15/16	5-1/4	27	8	10-1/2	24-13/16	2-1/8	13/16	579
270	34-7/8	58-1/2	1-7/16	1-11/16	1-15/16	5-3/8	30	9	11-7/16	26-13/16	2-1/8	13/16	690
300	37-11/16	64-3/4	1-11/16	1-15/16	2-3/16	6	33	10	12-5/8	29-13/16	2-1/8	13/16	836
330	40-1/2	71	1-11/16	2-3/16	2-3/16	6-11/16	36	12	13-3/4	32-3/4	2-1/8	13/16	994
365	43-5/8	77-7/8	1-15/16	2-7/16	2-7/16	7-7/16	40	13	15-1/16	35-13/16	2-1/8	13/16	1193
402	47-1/8	87-7/16	1-15/16	2-7/16	2-11/16	7-13/16	44	14	17-1/8	39-11/16	1-3/16	1-1/16	1415
445	50-7/8	96	1-15/16	2-11/16	2-15/16	9-13/16	48	16	18-3/4	43-11/16	1-3/16	1-1/16	1702
490	55-13/16	104-7/8	2-3/16	2-11/16	2-15/16	10-15/16	53	18	20-1/2	47-5/8	1-11/16	1-1/16	2028
540	62-1/8	115-7/16	2-7/16	2-15/16	3-7/16	12-3/4	58	20	22-3/8	52-11/16	2-11/16	1-1/16	2475
600	67-5/16	129-3/8	2-11/16	3-7/16	3-15/16	15-1/16	64	22	24-5/8	58-5/8	2-3/4	1-1/16	2997
660	74-7/16	141-15/16	3-7/16	3-15/16	4-7/16	17-1/4	70	25	27	63-15/16	3-3/4	1-1/16	3565
730	80-1/4	156-1/2	3-7/16	3-15/16	4-7/16	20-1/8	77	28	29-5/8	71-1/2	3-3/4	1-1/16	4282

ALL DIMENSIONS IN INCHES. WEIGHTS IN LBS., LESS MOTOR.

*BASED ON CLASS I CONSTRUCTION.

CF402R02