



COOK

CF SWSI

DATE: _____

PROJECT: _____

LOCATION: _____



**Flat Blade Centrifugal Blower
Counterclockwise Down Blast
Arrangement 3**

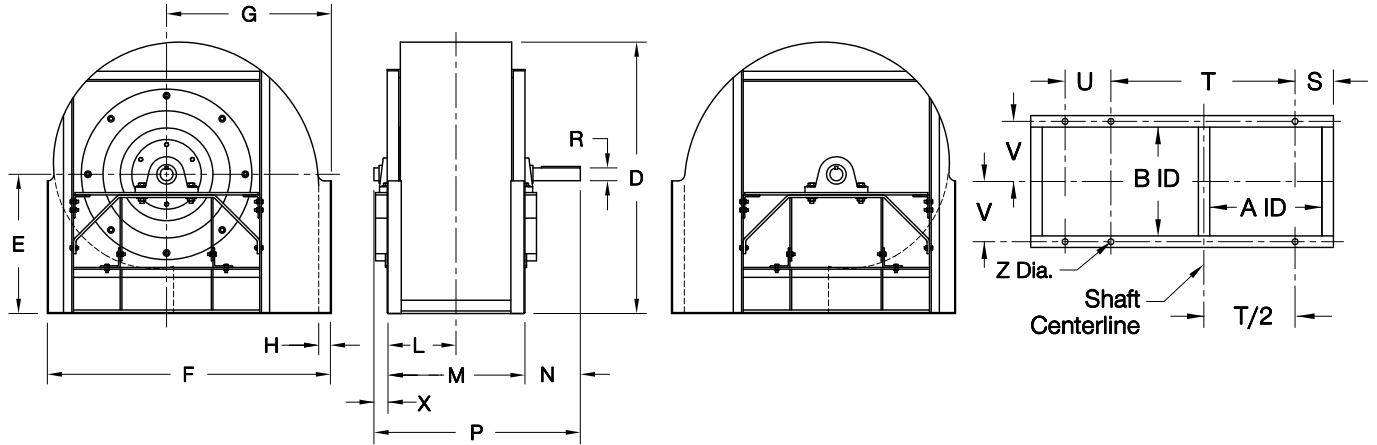

DIMENSION DATA

Size	A	B	D	E	F	G	H	L	M	N	P	R		
												Class I	Class II	Class III
120	13-1/8	9-3/16	24-3/8	13	25-3/4	15-1/16	2	6-5/8	13-3/16	4-5/8	19-7/16	1	1	1-3/16
135	14-3/4	10-5/16	25-9/16	14	28-3/4	16-11/16	2	7-3/16	14-5/16	4-5/8	20-9/16	1	1	1-3/16
150	16-7/16	11-7/16	29-1/4	15	31-5/8	18-5/16	2	7-3/4	15-7/16	4-5/8	21-11/16	1	1	1-3/16
165	18-1/16	12-5/8	32-5/8	17	34-3/8	19-15/16	2	8-5/16	16-5/8	5-5/8	23-7/8	1	1	1-3/16
180	19-11/16	13-3/4	35-1/8	18	37-1/8	21-9/16	2	8-7/8	17-3/4	6-1/8	25-1/2	1-3/16	1-7/16	1-11/16
195	21-5/16	14-15/16	38-1/2	20	40	23-3/16	2	9-1/2	18-15/16	6-1/8	26-11/16	1-7/16	1-7/16	1-11/16
210	23	16-1/16	40-15/16	21	42-7/8	24-7/8	2	10-1/16	20-1/16	6-5/8	28-5/16	1-7/16	1-7/16	1-11/16
225	24-5/8	17-3/16	44-3/8	23	45-3/4	26-1/2	2	10-5/8	21-3/16	6-5/8	29-7/16	1-7/16	1-7/16	1-11/16
245	26-13/16	18-3/4	48-1/4	25	49-1/2	28-5/8	2	11-3/8	22-3/4	7-5/8	32-1/2	1-7/16	1-11/16	1-15/16
270	29-9/16	20-5/8	50-1/8	27	54-3/4	31-3/8	2	12-5/16	24-5/8	8-1/8	34-7/8	1-7/16	1-11/16	1-15/16
300	32-13/16	22-15/16	58-1/2	30	60	34-5/8	2	13-1/2	26-15/16	8-5/8	37-11/16	1-11/16	1-15/16	2-3/16
330	36-1/8	25-1/4	64-3/8	33	65-3/4	37-7/8	2	14-5/8	29-1/4	9-1/8	40-1/2	1-11/16	2-3/16	2-3/16
365	39-15/16	27-7/8	70-5/8	36	72-3/8	41-3/4	2	15-15/16	31-7/8	9-5/8	43-5/8	1-15/16	2-7/16	2-7/16
402	44-1/16	30-3/4	78-1/4	40	80-3/8	46-3/4	3	18-3/8	36-3/4	9-3/16	47-1/8	1-15/16	2-7/16	2-11/16
445	48-11/16	34	86-1/4	44	88-1/2	51-3/8	3	20	40	9-11/16	50-7/8	1-15/16	2-11/16	2-15/16
490	53-5/8	37-7/16	94-1/2	48	97	56-1/4	3	21-3/4	43-7/16	10-11/16	55-13/16	2-3/16	2-11/16	2-15/16
540	59-1/16	41-1/4	104-1/4	53	106-5/8	61-3/4	3	23-5/8	47-1/4	12-3/16	62-1/8	2-7/16	2-15/16	3-7/16
600	65-5/8	45-13/16	116	59	118	68-1/4	3	25-15/16	51-13/16	12-3/4	67-5/16	2-11/16	3-7/16	3-15/16
660	72-3/16	50-7/16	121-5/8	65	129-3/8	74-3/4	3	28-1/4	56-7/16	14-1/4	74-7/16	3-7/16	3-15/16	4-7/16
730	79-7/8	55-3/4	141-5/16	72	142-5/8	82-3/8	3	30-7/8	61-3/4	14-3/4	80-1/4	3-7/16	3-15/16	4-7/16

Size	S	T	U	V	X	Z	Ship Wt. *
120	3-3/16	15	-	5-3/4	1-5/8	11/16	157
135	3-9/16	17	-	6-5/16	1-5/8	11/16	195
150	4-5/16	18	-	6-7/8	1-5/8	11/16	236
165	4-7/16	20	-	7-7/16	1-5/8	11/16	280
180	4-9/16	22	-	8	1-5/8	11/16	328
195	5-5/16	23	9	8-5/8	1-5/8	11/16	379
210	6	24	10	9-3/16	1-5/8	13/16	437
225	6-3/4	25	10	9-3/4	1-5/8	13/16	496
245	7-3/8	27	11	10-1/2	2-1/8	13/16	579
270	8-3/8	30	12	11-7/16	2-1/8	13/16	690
300	8-7/8	33	14	12-5/8	2-1/8	13/16	836
330	9-7/8	36	16	13-3/4	2-1/8	13/16	994
365	10-5/8	40	17	15-1/16	2-1/8	13/16	1193
402	11-5/8	44	20	17-1/8	1-3/16	1-1/16	1415
445	13-1/8	48	23	18-3/4	1-3/16	1-1/16	1702
490	14-1/4	53	26	20-1/2	1-11/16	1-1/16	2028
540	15-7/8	58	29	22-3/8	2-11/16	1-1/16	2475
600	17-3/4	64	32	24-5/8	2-3/4	1-1/16	2997
660	19-5/8	70	36	27	3-3/4	1-1/16	3565
730	21-3/4	77	40	29-5/8	3-3/4	1-1/16	4282

ALL DIMENSIONS IN INCHES. WEIGHTS IN LBS., LESS MOTOR. * BASED ON CLASS I CONSTRUCTION

CF404R02