



COOK

CF SWSI

DATE: _____
 PROJECT: _____
 LOCATION: _____



**Flat Blade Centrifugal Blower
 Counterclockwise Bottom Horizontal
 Arrangement 3**

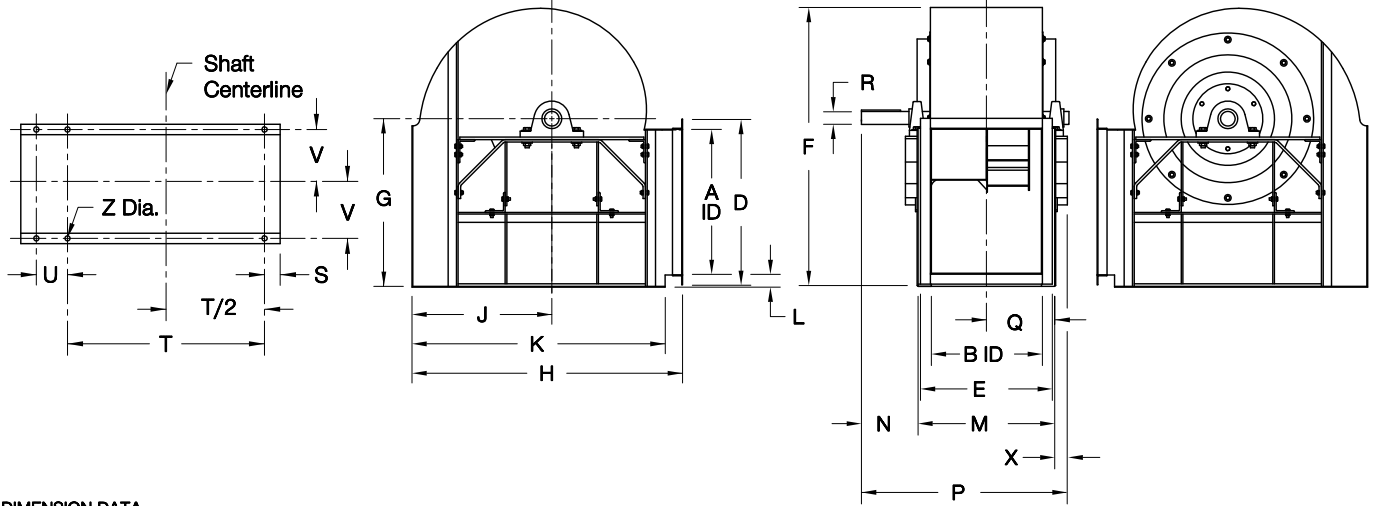

DIMENSION DATA

Size	A	B	D	E	F	G	H	J	K	L	M
120	13-1/8	9-3/16	16-5/16	12-3/8	25-3/4	16	24-1/2	12-3/8	21-1/2	2-15/16	13-3/16
135	14-3/4	10-5/16	17-15/16	13-1/2	28	17	27	13-7/8	24	2-5/16	14-5/16
150	16-7/16	11-7/16	19-5/8	14-5/8	31-3/16	19	29	15-3/16	26	2-11/16	15-7/16
165	18-1/16	12-5/8	21-1/4	15-13/16	34-3/8	21	31-1/2	16-5/8	28-1/2	3-1/16	16-5/8
180	19-11/16	13-3/4	22-7/8	16-15/16	36-5/8	22	33-3/4	18-1/8	30-3/4	2-7/16	17-3/4
195	21-5/16	14-15/16	24-1/2	18-3/16	39-13/16	24	36-1/4	19-7/16	33	2-13/16	18-15/16
210	23	16-1/16	26-3/16	19-5/16	43-1/16	26	41	21	38	3-1/8	20-1/16
225	24-5/8	17-3/16	27-13/16	20-7/16	46-1/4	28	43	22-3/8	40	3-1/2	21-3/16
245	26-13/16	18-3/4	30	22	49-7/8	30	46	24-1/4	43	3-3/8	22-3/4
270	29-9/16	20-5/8	32-3/4	23-7/8	54-15/16	33	50	26-5/8	47	3-5/8	24-5/8
300	32-13/16	22-15/16	36	26-3/16	60-3/8	36	55-3/8	29-1/2	52	3-3/8	26-15/16
330	36-1/8	25-1/4	40-5/16	29-7/16	65-13/16	39	60-3/4	32-5/16	57	3-1/8	29-1/4
365	39-15/16	27-7/8	44-3/16	32-1/16	72-5/8	43	67	35-9/16	63	3-1/4	31-7/8
402	44-1/16	30-3/4	48-5/16	34-15/16	79-5/8	47	73-7/8	39-3/16	69	3-1/4	36-3/4
445	48-11/16	34	52-15/16	38-3/16	88-1/8	52	81-1/2	43-3/16	77	3-5/8	40
490	53-5/8	37-7/16	57-7/8	41-5/8	96-3/4	57	89-3/4	47-9/16	85	3-3/4	43-7/16
540	59-1/16	41-1/4	63-5/16	45-7/16	105-13/16	62	98-3/4	52-1/4	94	3-1/4	47-1/4
600	65-5/8	45-13/16	70	50-3/16	117-11/16	69	109-5/8	57-15/16	105	3-3/4	51-13/16
660	72-3/16	50-7/16	76-9/16	54-13/16	128-9/16	75	120-5/8	63-3/4	116	3-1/4	56-7/16
730	79-7/8	55-3/4	84-1/4	60-1/8	142-1/4	83	133-1/4	70-3/8	129	3-5/8	61-3/4

Size	N	P	Q	R			S	T	U	V	X	Z	Ship Wt. *
				Class I	Class II	Class III							
120	4-5/8	19-7/16	6-5/8	1	1	1-3/16	1-5/8	15	-	5-3/4	1-5/8	11/16	157
135	4-5/8	20-9/16	7-3/16	1	1	1-3/16	1-5/8	17	-	6-5/16	1-5/8	11/16	195
150	4-5/8	21-11/16	7-3/4	1	1-3/16	1-7/16	1-13/16	18	-	6-7/8	1-5/8	11/16	236
165	5-5/8	23-7/8	8-5/16	1	1-3/16	1-7/16	1-7/8	20	-	7-7/16	1-5/8	11/16	280
180	6-1/8	25-1/2	8-7/8	1-3/16	1-7/16	1-11/16	1-5/8	22	-	8	1-5/8	11/16	328
195	6-1/8	26-11/16	9-1/2	1-7/16	1-7/16	1-11/16	2-1/16	23	6	8-5/8	1-5/8	11/16	379
210	6-5/8	28-5/16	10-1/16	1-7/16	1-7/16	1-11/16	5	24	7	9-3/16	1-5/8	13/16	437
225	6-5/8	29-7/16	10-5/8	1-7/16	1-7/16	1-11/16	5-1/8	25	7-1/2	9-3/4	1-5/8	13/16	496
245	7-5/8	32-1/2	11-3/8	1-7/16	1-11/16	1-15/16	5-1/4	27	8	10-1/2	2-1/8	13/16	579
270	8-1/8	34-7/8	12-5/16	1-7/16	1-11/16	1-15/16	5-3/8	30	9	11-7/16	2-1/8	13/16	690
300	8-5/8	37-11/16	13-1/2	1-11/16	1-15/16	2-3/16	6	33	10	12-5/8	2-1/8	13/16	836
330	9-1/8	40-1/2	14-5/8	1-11/16	2-3/16	2-3/16	6-11/16	36	12	13-3/4	2-1/8	13/16	994
365	9-5/8	43-5/8	15-15/16	1-15/16	2-7/16	2-7/16	7-7/16	40	13	15-1/16	2-1/8	13/16	1193
402	9-3/16	47-1/8	18-3/8	1-15/16	2-7/16	2-11/16	7-13/16	44	14	17-1/8	1-3/16	1-1/16	1415
445	9-11/16	50-7/8	20	1-15/16	2-11/16	2-15/16	9-13/16	48	16	18-3/4	1-3/16	1-1/16	1702
490	10-11/16	55-13/16	21-3/4	2-3/16	2-11/16	2-15/16	10-15/16	53	18	20-1/2	1-11/16	1-1/16	2028
540	12-3/16	62-1/8	23-5/8	2-7/16	2-15/16	3-7/16	12-3/4	58	20	22-3/8	2-11/16	1-1/16	2475
600	12-3/4	67-5/16	25-15/16	2-11/16	3-7/16	3-15/16	15-1/16	64	22	24-5/8	2-3/4	1-1/16	2997
660	14-1/4	74-7/16	28-1/4	3-7/16	3-15/16	4-7/16	17-1/4	70	25	27	3-3/4	1-1/16	3565
730	14-3/4	80-1/4	30-7/8	3-7/16	3-15/16	4-7/16	20-1/8	77	28	29-5/8	3-3/4	1-1/16	4282

ALL DIMENSIONS IN INCHES. WEIGHTS IN LBS., LESS MOTOR. * BASED ON CLASS I CONSTRUCTION.

CF408R02