



COOK

CF SWSI

DATE: _____
 PROJECT: _____
 LOCATION: _____



Flat Blade Centrifugal Blower
Clockwise Top Angular Up
Arrangement 3

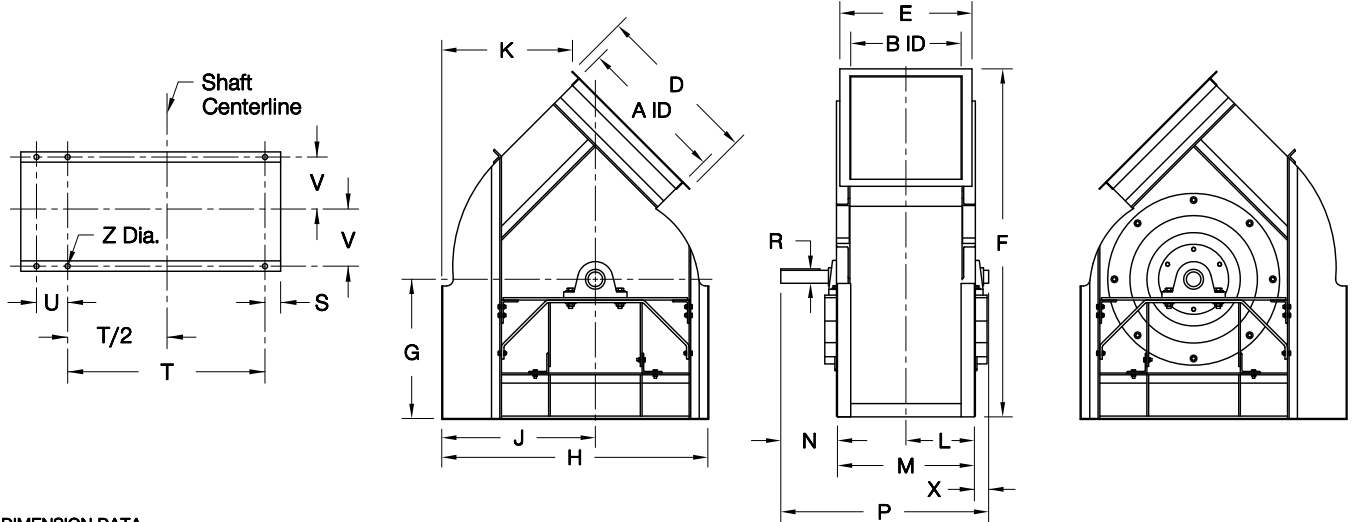

DIMENSION DATA

Size	A	B	D	E	F	G	H	J	K	L	M	N
120	13-1/8	9-3/16	16-5/16	12-3/8	30-3/4	13	24	13	10	6-5/8	13-3/16	4-5/8
135	14-3/4	10-5/16	17-15/16	13-1/2	33-3/16	14	27	15	11-3/4	7-3/16	14-5/16	4-5/8
150	16-7/16	11-7/16	19-5/8	14-5/8	36-7/8	15	29	16	12-9/16	7-3/4	15-7/16	4-5/8
165	18-1/16	12-5/8	21-1/4	15-13/16	40-15/16	17	32	18	14-5/16	8-5/16	16-5/8	5-5/8
180	19-11/16	13-3/4	22-7/8	16-15/16	44	18	35	21	16-1/16	8-7/8	17-3/4	6-1/8
195	21-5/16	14-15/16	24-1/2	18-3/16	48-1/16	20	37	21	16-7/8	9-1/2	18-15/16	6-1/8
210	23	16-1/16	26-3/16	19-5/16	51-3/16	21	40	23	18-9/16	10-1/16	20-1/16	6-5/8
225	24-5/8	17-3/16	27-13/16	20-7/16	55-3/16	23	42	24	19-5/16	10-5/8	21-3/16	6-5/8
245	26-13/16	18-3/4	30	22	59-15/16	25	46	26	21-1/16	11-3/8	22-3/4	7-5/8
270	29-9/16	20-5/8	32-3/4	23-7/8	65-7/16	27	50	29	23-5/8	12-5/16	24-5/8	8-1/8
300	32-13/16	22-15/16	36	26-3/16	72-9/16	30	56	32	26-3/16	13-1/2	26-15/16	8-5/8
330	36-1/8	25-1/4	40-5/16	29-7/16	80	33	61	35	28-5/16	14-5/8	29-1/4	9-1/8
365	39-15/16	27-7/8	44-3/16	32-1/16	83-7/8	36	67	39	31-11/16	15-15/16	31-7/8	9-5/8
402	44-1/16	30-3/4	48-5/16	34-15/16	97	40	73	42	34-3/16	18-3/8	36-3/4	9-3/16
445	48-11/16	34	52-15/16	38-3/16	106-13/16	44	81	47	38-1/2	20	40	9-11/16
490	53-5/8	37-7/16	57-7/8	41-5/8	117	48	89	51	41-3/4	21-3/4	43-7/16	10-11/16
540	59-1/16	41-1/4	63-5/16	45-7/16	128-15/16	53	97	56	45-15/16	23-5/8	47-1/4	12-3/16
600	65-5/8	45-13/16	70	50-3/16	143-3/16	59	108	62	51	25-15/16	51-13/16	12-3/4
660	72-3/16	50-7/16	76-9/16	54-13/16	157-1/2	65	119	69	57-1/16	28-1/4	56-7/16	14-1/4
730	79-7/8	55-3/4	84-1/4	60-1/8	174-3/8	72	131	76	62-15/16	30-7/8	61-3/4	14-3/4

Size	P	R			S	T	U	V	X	Z	Ship Wt. *
		Class I	Class II	Class III							
120	19-7/16	1	1	1-3/16	3-1/2	15	-	5-3/4	1-5/8	11/16	157
135	20-9/16	1	1	1-3/16	3-1/2	17	-	6-5/16	1-5/8	11/16	195
150	21-11/16	1	1-3/16	1-7/16	4	18	-	6-7/8	1-5/8	11/16	236
165	23-7/8	1	1-3/16	1-7/16	4	20	-	7-7/16	1-5/8	11/16	280
180	25-1/2	1-3/16	1-7/16	1-11/16	4	22	-	8	1-5/8	11/16	328
195	26-11/16	1-7/16	1-7/16	1-11/16	4-1/2	23	6-1/2	8-5/8	1-5/8	11/16	379
210	28-5/16	1-7/16	1-7/16	1-11/16	5	24	8	9-3/16	1-5/8	13/16	437
225	29-7/16	1-7/16	1-7/16	1-11/16	5-1/2	25	8-1/2	9-3/4	1-5/8	13/16	496
245	32-1/2	1-7/16	1-11/16	1-15/16	6-1/2	27	9-1/2	10-1/2	2-1/8	13/16	579
270	34-7/8	1-7/16	1-11/16	1-15/16	7	30	10	11-7/16	2-1/8	13/16	690
300	37-11/16	1-11/16	1-15/16	2-3/16	7-1/2	33	11-1/2	12-5/8	2-1/8	13/16	836
330	40-1/2	1-11/16	2-3/16	2-3/16	8	36	13	13-3/4	2-1/8	13/16	994
365	43-5/8	1-15/16	2-7/16	2-7/16	8	40	15	15-1/16	2-1/8	13/16	1193
402	47-1/8	1-15/16	2-7/16	2-11/16	9	44	16	17-1/8	1-3/16	1-1/16	1415
445	50-7/8	1-15/16	2-11/16	2-15/16	10	48	19	18-3/4	1-3/16	1-1/16	1702
490	55-13/16	2-3/16	2-11/16	2-15/16	11-1/2	53	20-1/2	20-1/2	1-11/16	1-1/16	2028
540	62-1/8	2-7/16	2-15/16	3-7/16	12	58	23	22-3/8	2-11/16	1-1/16	2475
600	67-5/16	2-11/16	3-7/16	3-15/16	14	64	26	24-5/8	2-3/4	1-1/16	2997
660	74-7/16	3-7/16	3-15/16	4-7/16	15	70	30	27	3-3/4	1-1/16	3565
730	80-1/4	3-7/16	3-15/16	4-7/16	16-1/2	77	33-1/2	29-5/8	3-3/4	1-1/16	4282

ALL DIMENSIONS IN INCHES. WEIGHTS IN LBS., LESS MOTOR. * BASED ON CLASS I CONSTRUCTION.

CF409R02