



COOK

CF SWSI

DATE: _____
 PROJECT: _____
 LOCATION: _____



Flat Blade Centrifugal Blower
Counterclockwise Bottom Angular Up
Arrangement 3

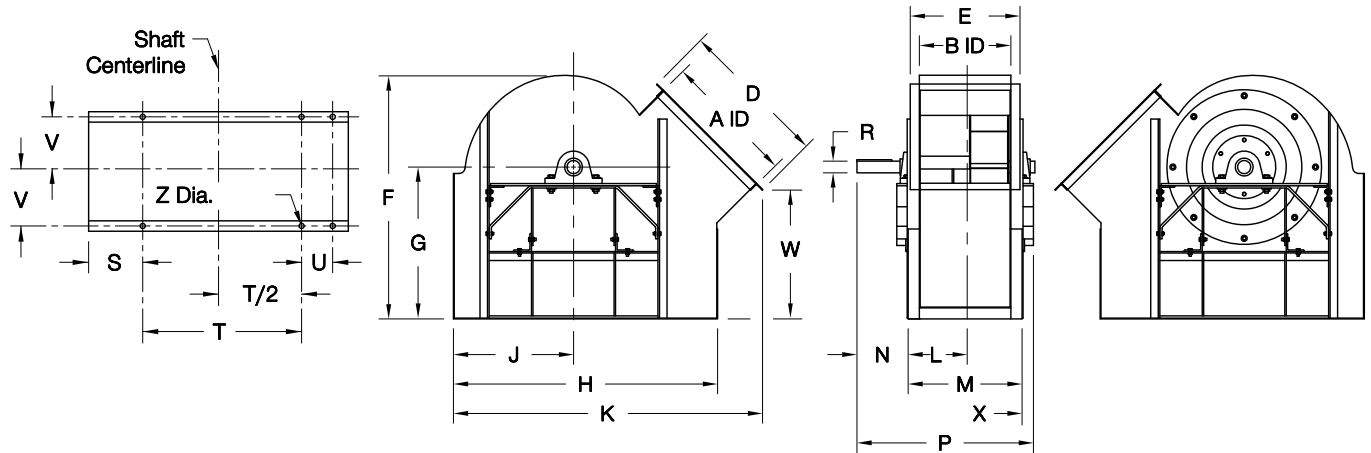

DIMENSION DATA

Size	A	B	D	E	F	G	H	J	K	L	M	N
120	13-1/8	9-3/16	16-5/16	12-3/8	25	16	26	12	29-3/4	6-5/8	13-3/16	4-5/8
135	14-3/4	10-5/16	17-15/16	13-1/2	27	17	29	13	32-3/4	7-3/16	14-5/16	4-5/8
150	16-7/16	11-7/16	19-5/8	14-5/8	30-1/8	19	32	14	35-13/16	7-3/4	15-7/16	4-5/8
165	18-1/16	12-5/8	21-1/4	15-13/16	33-1/16	21	35	16	39-7/8	8-5/16	16-5/8	5-5/8
180	19-11/16	13-3/4	22-7/8	16-15/16	35-1/4	22	37	17	42-15/16	8-7/8	17-3/4	6-1/8
195	21-5/16	14-15/16	24-1/2	18-3/16	38-3/8	24	40	18	46	9-1/2	18-15/16	6-1/8
210	23	16-1/16	26-3/16	19-5/16	41-5/8	26	44	20	50-1/8	10-1/16	20-1/16	6-5/8
225	24-5/8	17-3/16	27-13/16	20-7/16	44-3/4	28	46	21	53-3/16	10-5/8	21-3/16	6-5/8
245	26-13/16	18-3/4	30	22	48-1/8	30	50	23	57-15/16	11-3/8	22-3/4	7-5/8
270	29-9/16	20-5/8	32-3/4	23-7/8	53	33	55	25	63-5/16	12-5/16	24-5/8	8-1/8
300	32-13/16	22-15/16	36	26-3/16	58-1/4	36	61	28	70-1/2	13-1/2	26-15/16	8-5/8
330	36-1/8	25-1/4	40-5/16	29-7/16	63-1/2	39	68	31	77-15/16	14-5/8	29-1/4	9-1/8
365	39-15/16	27-7/8	44-3/16	32-1/16	70	43	74	34	85-13/16	15-15/16	31-7/8	9-5/8
402	44-1/16	30-3/4	48-5/16	34-15/16	76-3/4	47	80	37	94	18-3/8	36-3/4	9-3/16
445	48-11/16	34	52-15/16	38-3/16	85	52	89	41	103-13/16	20	40	9-11/16
490	53-5/8	37-7/16	57-7/8	41-5/8	93-1/4	57	98	45	114	21-3/4	43-7/16	10-11/16
540	59-1/16	41-1/4	63-5/16	45-7/16	102-13/16	62	106	49	124-15/16	23-5/8	47-1/4	12-3/16
600	65-5/8	45-13/16	70	50-3/16	113-3/8	69	118	54	138-1/4	25-15/16	51-13/16	12-3/4
660	72-3/16	50-7/16	76-9/16	54-13/16	123-3/4	75	130	60	152-7/16	28-1/4	56-7/16	14-1/4
730	79-7/8	55-3/4	84-1/4	60-1/8	137	83	143	66	168-1/8	30-7/8	61-3/4	14-3/4

Size	P	R			S	T	U	V	W	X	Z	Ship. Wt. *
		Class I	Class II	Class III								
120	19-7/16	1	1	1-3/16	4-1/2	15	-	5-3/4	13	1-5/8	11/16	157
135	20-9/16	1	1	1-3/16	4-1/2	17	-	6-5/16	13-11/16	1-5/8	11/16	195
150	21-11/16	1	1-3/16	1-7/16	5	18	-	6-7/8	15-1/2	1-5/8	11/16	236
165	23-7/8	1	1-3/16	1-7/16	6	20	-	7-7/16	17-1/4	1-5/8	11/16	280
180	25-1/2	1-3/16	1-7/16	1-11/16	6	22	-	8	18	1-5/8	11/16	328
195	26-11/16	1-7/16	1-7/16	1-11/16	6-1/2	23	7-1/2	8-5/8	19-3/4	1-5/8	11/16	379
210	28-5/16	1-7/16	1-7/16	1-11/16	8	24	9	9-3/16	21-1/2	1-5/8	13/16	437
225	29-7/16	1-7/16	1-7/16	1-11/16	8-1/2	25	9-1/2	9-3/4	23-1/4	1-5/8	13/16	496
245	32-1/2	1-7/16	1-11/16	1-15/16	9-1/2	27	10-1/2	10-1/2	25	2-1/8	13/16	579
270	34-7/8	1-7/16	1-11/16	1-15/16	10	30	12	11-7/16	27-9/16	2-1/8	13/16	690
300	37-11/16	1-11/16	1-15/16	2-3/16	11-1/2	33	13-1/2	12-5/8	30-1/16	2-1/8	13/16	836
330	40-1/2	1-11/16	2-3/16	2-3/16	13	36	15	13-3/4	32-1/4	2-1/8	13/16	994
365	43-5/8	1-15/16	2-7/16	2-7/16	14	40	16	15-1/16	35-5/8	2-1/8	13/16	1193
402	47-1/8	1-15/16	2-7/16	2-11/16	15	44	17	17-1/8	39-1/16	1-3/16	1-1/16	1415
445	50-7/8	1-15/16	2-11/16	2-15/16	17	48	20	18-3/4	43-3/8	1-3/16	1-1/16	1702
490	55-13/16	2-3/16	2-11/16	2-15/16	18-1/2	53	22-1/2	20-1/2	47-11/16	1-11/16	1-1/16	2028
540	62-1/8	2-7/16	2-15/16	3-7/16	20	58	24	22-3/8	51-13/16	2-11/16	1-1/16	2475
600	67-5/16	2-11/16	3-7/16	3-15/16	22	64	28	24-5/8	57-7/8	2-3/4	1-1/16	2997
660	74-7/16	3-7/16	3-15/16	4-7/16	25	70	31	27	63	3-3/4	1-1/16	3565
730	80-1/4	3-7/16	3-15/16	4-7/16	27-1/2	77	34-1/2	29-5/8	69-13/16	3-3/4	1-1/16	4282

ALL DIMENSIONS IN INCHES. WEIGHTS IN LBS., LESS MOTOR. * BASED ON CLASS I CONSTRUCTION.

CF412R03