

DATE: _____

PROJECT: _____

LOCATION: _____



Flat Blade Centrifugal Blower Clockwise Top Angular Up Arrangement 8

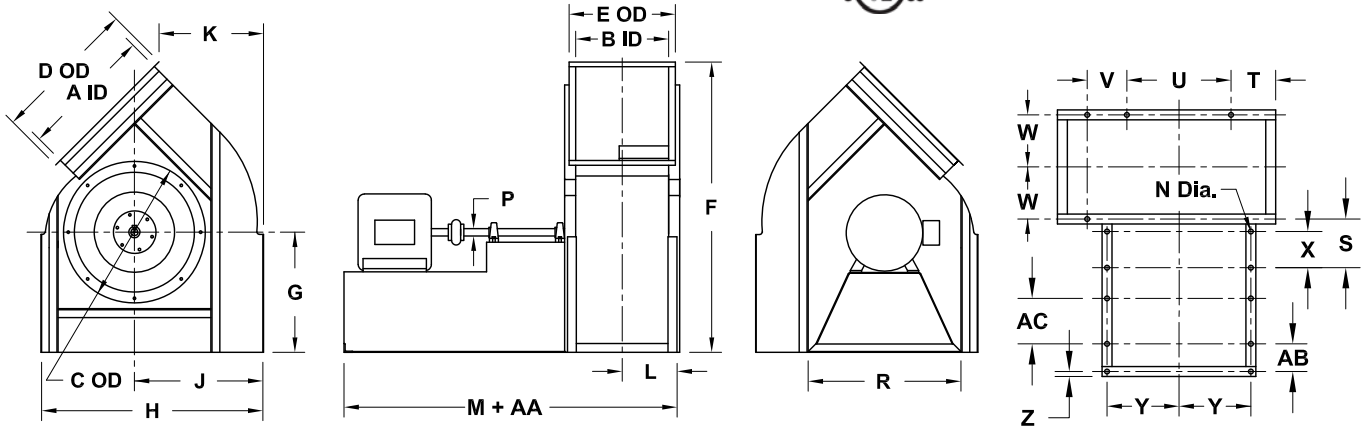

DIMENSION DATA

Size	A	B	C	D	E	F	G	H	J	K	L	M	N
120	13-1/8	9-3/16	16-1/8	16-5/16	12-3/8	30-3/4	13	24	13	10	6-5/8	26-1/4	11/16
135	14-3/4	10-5/16	17-5/8	17-5/16	13-1/2	33-3/16	14	27	15	11-3/4	7-3/16	27-3/8	11/16
150	16-7/16	11-7/16	19-1/8	19-5/8	14-5/8	36-7/8	15	29	16	12-9/16	7-3/4	30-1/2	11/16
165	18-1/16	12-5/8	21-3/16	21-1/4	15-13/16	40-15/16	17	32	18	14-5/16	8-5/16	32-5/8	11/16
180	19-11/16	13-3/4	22-11/16	22-7/8	16-15/16	44	18	35	20	16-1/16	8-7/8	36-1/4	11/16
195	21-5/16	14-15/16	24-3/16	24-1/2	18-3/16	48-1/16	20	37	21	16-7/8	9-1/2	37-1/2	11/16
210	23	16-1/16	25-15/16	26-3/16	19-5/16	51-3/16	21	40	23	18-9/16	10-1/16	41-1/8	13/16
225	24-5/8	17-3/16	27-7/16	27-13/16	20-7/16	55-3/16	23	42	24	19-5/16	10-5/8	42-1/4	13/16
245	26-13/16	18-3/4	29-7/16	30	22	59-15/16	25	46	26	21-1/16	11-3/8	46-1/4	13/16
270	29-9/16	20-5/8	31-15/16	32-3/4	23-7/8	65-7/16	27	50	29	23-5/8	12-5/16	48-5/8	13/16
300	32-13/16	22-15/16	34-15/16	36	26-3/16	72-9/16	30	56	32	26-3/16	13-1/2	53-1/2	13/16
330	36-1/8	25-1/4	37-15/16	40-5/16	29-7/16	80	33	61	35	28-5/16	14-5/8	56-1/4	13/16
365	39-15/16	27-7/8	41-7/16	44-3/16	32-1/16	87-7/8	36	67	39	31-11/16	15-15/16	63-1/4	13/16
402	44-1/16	30-3/4	45-3/16	48-5/16	34-15/16	97	40	73	42	34-3/16	18-3/8	67-11/16	1-1/16
445	48-11/16	34	49-7/16	52-15/16	38-3/16	106-13/16	44	81	47	38-1/2	20	75-7/16	1-1/16
490	53-5/8	37-7/16	55	57-7/8	41-5/8	117	48	89	51	41-3/4	21-3/4	79-7/16	1-1/16
540	59-1/16	41-1/4	60	63-5/16	45-7/16	128-15/16	53	97	56	45-15/16	23-5/8	87-11/16	1-1/16
600	65-5/8	45-13/16	66	70	50-3/16	143-3/16	59	108	62	51	25-15/16	92-11/16	1-1/16
660	72-3/16	50-7/16	72	76-9/16	54-13/16	157-1/2	65	119	69	57-1/16	28-1/4	101-15/16	1-1/16
730	79-7/8	55-3/4	79	84-1/4	60-1/8	174-3/8	72	131	76	62-15/16	30-7/8	107-11/16	1-1/16

Size	P			R	S	T	U	V	W	X	Y	Z
	Class I	Class II	Class III									
120	1-3/16	1-7/16	1-11/16	18-3/8	12-1/8	3-1/2	15	-	5-3/4	9-3/4	8-7/16	3/4
135	1-3/16	1-7/16	1-11/16	19-7/8	12-1/8	3-1/2	17	-	6-5/16	9-3/4	9-3/16	3/4
150	1-3/16	1-7/16	1-11/16	21-3/8	14-1/8	4	18	-	6-7/8	11-3/4	9-15/16	3/4
165	1-3/16	1-7/16	1-11/16	23-3/8	14-1/8	4	20	-	7-7/16	11-3/4	10-15/16	3/4
180	1-7/16	1-11/16	1-11/16	24-7/8	16-1/8	4	22	-	8	13-3/4	11-11/16	3/4
195	1-7/16	1-11/16	1-11/16	26-3/8	16-1/8	4-1/2	23	6-1/2	8-5/8	13-3/4	12-7/16	3/4
210	1-7/16	1-11/16	1-15/16	28-1/8	18-1/8	5	24	8	9-3/16	15-3/4	13-5/16	3/4
225	1-7/16	1-11/16	1-15/16	29-5/8	18-1/8	5-1/2	25	8-1/2	9-3/4	15-3/4	14-1/16	3/4
245	1-11/16	1-15/16	2-3/16	31-5/8	20-1/8	6-1/2	27	9-1/2	10-1/2	17-3/4	15-1/16	3/4
270	1-11/16	1-15/16	2-3/16	34-3/8	20-1/8	7	30	10	11-7/16	17-3/4	16-7/16	3/4
300	1-15/16	2-3/16	2-7/16	37-3/8	22-1/8	7-1/2	33	11-1/2	12-5/8	19-3/4	17-15/16	3/4
330	1-15/16	2-3/16	2-7/16	40-3/8	22-1/8	8	36	13	13-3/4	19-3/4	19-7/16	3/4
365	2-3/16	2-7/16	2-15/16	44-7/8	26	8	40	15	15-1/16	23-3/4	21-11/16	3/4
402	2-3/16	2-7/16	2-15/16	48-3/4	26-3/16	9	44	16	17-1/8	23-3/4	23-3/8	1
445	2-7/16	2-15/16	3-7/16	53	30-3/16	10	48	19	18-3/4	27-3/4	25-1/2	1
490	2-7/16	2-15/16	3-7/16	58-1/2	30-3/16	11-1/2	53	20-1/2	20-1/2	27-3/4	28-1/4	1
540	2-15/16	3-7/16	3-15/16	63-1/2	34-3/16	12	58	23	22-3/8	31-3/4	30-3/4	1
600	2-15/16	3-7/16	3-15/16	69-1/2	34-3/16	14	64	26	24-5/8	31-3/4	33-3/4	1
660	3-7/16	3-15/16	4-7/16	75-1/2	38-3/16	15	70	30	27	35-3/4	36-3/4	1
730	3-7/16	3-15/16	4-7/16	82-1/2	38-3/16	16-1/2	77	33-1/2	29-5/8	35-3/4	40-1/4	1

Motor Frame	AA	AB	AC
56	15-1/4	3-9/16	6
143T	16-3/8	3-13/16	7
145T	16-1/2	2-15/16	8
182T	18-1/2	3-15/16	7-1/2
184T	18-1/2	2-15/16	8-1/2
213T	22-7/8	5-3/8	8-1/2
215T	22-7/8	3-7/8	10
254T	28-9/16	6-7/8	11-1/4
256T	28-9/16	5-1/8	13
284T	31-9/16	6-11/16	12-1/2
286T	31-9/16	5-3/16	14
324T	35	7-13/16	13-1/2
326T	35	6-5/16	15
364T	37-11/16	7-13/16	14-1/4
365T	38-11/16	7-13/16	15-1/4
404T	42-15/16	9-7/8	15-1/4
405T	44-7/16	9-7/8	16-3/4
444T	48-9/16	11-1/4	17-1/2
445T	50-7/8	11-1/2	19-1/2
447T	64-7/16	21-5/16	23
449T	66-7/8	18-5/8	28

ALL DIMENSIONS IN INCHES. FOOTPRINT HOLES ARE FOR SOLID MOUNTING ONLY. FOR VIBRATION ISOLATION, RAILS OR BASE ARE REQUIRED
DIMENSIONS M & AA ARE FOR PEDESTAL FOOTPRINT. MOTOR MAY EXTEND BEYOND PEDESTAL.