



COOK

CF SWSI

DATE: _____
 PROJECT: _____
 LOCATION: _____



Flat Blade Centrifugal Blower Counterclockwise Bottom Angular Up Arrangement 8

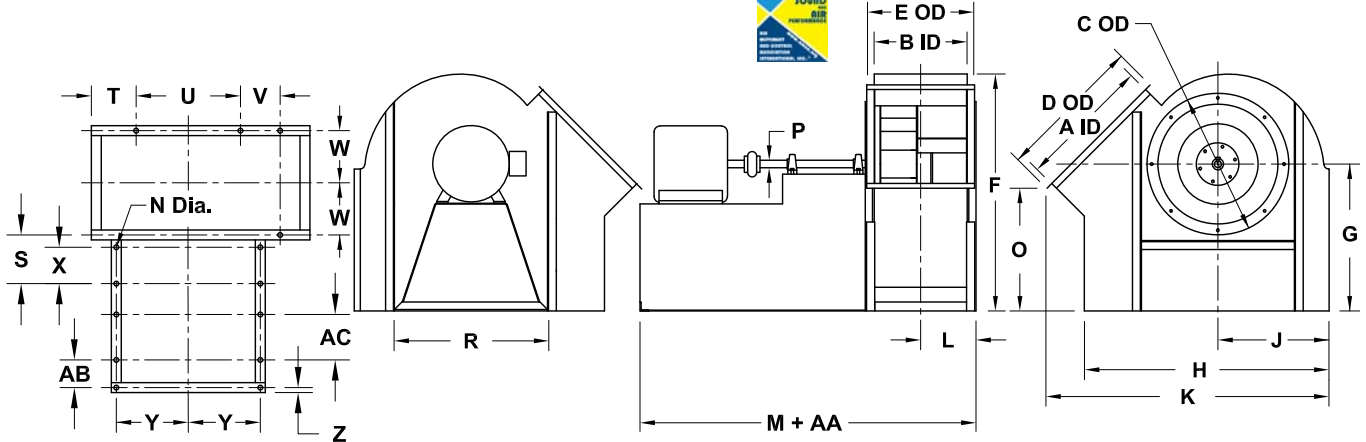

DIMENSION DATA

Size	A	B	C	D	E	F	G	H	J	K	L	M	N	O
120	13-1/8	9-3/16	16-1/8	16-5/16	12-3/8	25-1/16	16	26	12	29-7/8	6-5/8	26-1/4	11/16	13
135	14-3/4	10-5/16	17-5/8	17-5/16	13-1/2	27-3/16	17	29	13	32-15/16	7-3/16	27-3/8	11/16	13-11/16
150	16-7/16	11-7/16	19-1/8	19-5/8	14-5/8	30-5/16	19	32	14	36	7-3/4	30-1/2	11/16	15-1/2
165	18-1/16	12-5/8	21-3/16	21-1/4	15-13/16	33-7/16	21	35	16	40-1/16	8-5/16	32-5/8	11/16	17-1/4
180	19-11/16	13-3/4	22-11/16	22-7/8	16-15/16	35-1/2	22	37	17	43-1/8	8-7/8	36-1/4	11/16	18
195	21-5/16	14-15/16	24-3/16	24-1/2	18-3/16	38-5/8	24	40	18	46-5/16	9-1/2	37-1/2	11/16	19-3/4
210	23	16-1/16	25-15/16	26-3/16	19-5/16	41-3/4	26	44	20	50-1/4	10-1/16	41-1/8	13/16	21-1/2
225	24-5/8	17-3/16	27-7/16	27-13/16	20-7/16	44-7/8	28	46	21	53-5/16	10-5/8	42-1/4	13/16	23-1/4
245	26-13/16	18-3/4	29-7/16	30	22	48-3/8	30	50	23	58-1/8	11-3/8	46-1/4	13/16	25
270	29-9/16	20-5/8	31-15/16	32-3/4	23-7/8	53-1/4	33	55	25	63-1/2	12-5/16	48-5/8	13/16	27-9/16
300	32-13/16	22-15/16	34-15/16	36	26-3/16	58-7/16	36	61	28	70-11/16	13-1/2	53-1/2	13/16	30-1/16
330	36-1/8	25-1/4	37-15/16	40-5/16	29-7/16	63-11/16	39	68	31	78-1/8	14-5/8	56-1/4	13/16	32-1/4
365	39-15/16	27-7/8	41-7/16	44-3/16	32-1/16	70-5/16	43	74	34	86-1/16	15-15/16	63-1/4	13/16	35-5/8
402	44-1/16	30-3/4	45-3/16	48-5/16	34-15/16	77-1/8	47	80	37	94-1/8	18-3/8	67-11/16	1-1/16	39-1/16
445	48-11/16	34	49-7/16	52-15/16	38-3/16	85-1/4	52	89	41	104-3/8	20	75-7/16	1-1/16	43-3/8
490	53-5/8	37-7/16	55	57-7/8	41-5/8	93-5/8	57	98	45	114-3/16	21-3/4	79-7/16	1-1/16	47-11/16
540	59-1/16	41-1/4	60	63-5/16	45-7/16	102-5/16	62	106	49	125	23-5/8	87-11/16	1-1/16	51-13/16
600	65-5/8	45-13/16	66	70	50-3/16	113-13/16	69	118	54	138-5/16	25-15/16	92-11/16	1-1/16	57-7/8
660	72-3/16	50-7/16	72	76-9/16	54-13/16	124-1/4	75	130	60	152-5/8	28-1/4	101-15/16	1-1/16	63
730	79-7/8	55-3/4	79	84-1/4	60-1/8	137-1/2	83	143	66	169-3/16	30-7/8	107-11/16	1-1/16	69-13/16

Size	P			R	S	T	U	V	W	X	Y	Z
	Class I	Class II	Class III									
120	1-3/16	1-7/16	1-11/16	18-3/8	12-1/8	4-1/2	15	-	5-3/4	9-3/4	8-7/16	3/4
135	1-3/16	1-7/16	1-11/16	19-7/8	12-1/8	4-1/2	17	-	6-5/16	9-3/4	9-3/16	3/4
150	1-3/16	1-7/16	1-11/16	21-3/8	14-1/8	5	18	-	6-7/8	11-3/4	9-15/16	3/4
165	1-3/16	1-7/16	1-11/16	23-3/8	14-1/8	6	20	-	7-7/16	11-3/4	10-15/16	3/4
180	1-7/16	1-11/16	1-11/16	24-7/8	16-1/8	6	22	-	8	13-3/4	11-11/16	3/4
195	1-7/16	1-11/16	1-11/16	26-3/8	16-1/8	6-1/2	23	7-1/2	8-5/8	13-3/4	12-7/16	3/4
210	1-7/16	1-11/16	1-15/16	28-1/8	18-1/8	8	24	9	9-3/16	15-3/4	13-5/16	3/4
225	1-7/16	1-11/16	1-15/16	29-5/8	18-1/8	8-1/2	25	9-1/2	9-3/4	15-3/4	14-1/16	3/4
245	1-11/16	1-15/16	2-3/16	31-5/8	20-1/8	9-1/2	27	10-1/2	10-1/2	17-3/4	15-1/16	3/4
270	1-11/16	1-15/16	2-3/16	34-3/8	20-1/8	10	30	12	11-7/16	17-3/4	16-7/16	3/4
300	1-15/16	2-3/16	2-7/16	37-3/8	22-1/8	11-1/2	33	13-1/2	12-5/8	19-3/4	17-15/16	3/4
330	1-15/16	2-3/16	2-7/16	40-3/8	22-1/8	13	36	15	13-3/4	19-3/4	19-7/16	3/4
365	2-3/16	2-7/16	2-15/16	44-7/8	26	14	40	16	15-1/16	23-3/4	21-11/16	3/4
402	2-3/16	2-7/16	2-15/16	48-3/4	26-3/16	15	44	17	17-1/8	23-3/4	23-3/8	1
445	2-7/16	2-15/16	3-7/16	53	30-3/16	17	48	20	18-3/4	27-3/4	25-1/2	1
490	2-7/16	2-15/16	3-7/16	58-1/2	30-3/16	18-1/2	53	22-1/2	20-1/2	27-3/4	28-1/4	1
540	2-15/16	3-7/16	3-15/16	63-1/2	34-3/16	20	58	24	22-3/8	31-3/4	30-3/4	1
600	2-15/16	3-7/16	3-15/16	69-1/2	34-3/16	22	64	28	24-5/8	31-3/4	33-3/4	1
660	3-7/16	3-15/16	4-7/16	75-1/2	38-3/16	25	70	31	27	35-3/4	36-3/4	1
730	3-7/16	3-15/16	4-7/16	82-1/2	38-3/16	27-1/2	77	34-1/2	29-5/8	35-3/4	40-1/4	1

Motor Frame	AA	AB	AC
56	15-1/4	3-9/16	6
143T	16-3/8	3-13/16	7
145T	16-1/2	2-15/16	8
182T	18-1/2	3-15/16	7-1/2
184T	18-1/2	2-15/16	8-1/2
213T	22-7/8	5-3/8	8-1/2
215T	22-7/8	3-7/8	10
254T	28-9/16	6-7/8	11-1/4
256T	28-9/16	5-1/8	13
284T	31-9/16	6-11/16	12-1/2
286T	31-9/16	5-3/16	14
324T	35	7-13/16	13-1/2
326T	35	6-5/16	15
364T	37-11/16	7-13/16	14-1/4
365T	38-11/16	7-13/16	15-1/4
404T	42-15/16	9-7/8	15-1/4
405T	44-7/16	9-7/8	16-3/4
444T	48-9/16	11-1/4	17-1/2
445T	50-7/8	11-1/2	19-1/2
447T	64-7/16	21-5/16	23
449T	66-7/8	18-5/8	28

ALL DIMENSIONS IN INCHES. FOOTPRINT HOLES ARE FOR SOLID MOUNTING ONLY. FOR VIBRATION ISOLATION, RAILS OR BASE ARE REQUIRED
 DIMENSIONS M & AA ARE FOR PEDESTAL FOOTPRINT. MOTOR MAY EXTEND BEYOND PEDESTAL.

CF911R00