



COOK

TCNS-B

DATE: _____

PROJECT: _____

LOCATION: _____

**Tubular Centrifugal Inline
Roof Mounted / Supply
Belt Drive****DIMENSION DATA**

Size	A	B	C	D	E	F	G	H	J	T Sq.	Max. Mtr. Frame
60-100	22	9	28-1/4	16	3	33-1/4	18	32-15/16	13	24	143T
120	23	9	28-1/4	18	3	35	18	33-15/16	13	24	145T
135	24-1/2	14	42-1/4	21	3	39-1/8	18	41-1/4	13	28	145T
150	27	14	42-1/4	24	3	41-3/4	22	43-3/4	16-3/4	30	145T
165	28-1/2	14	42-1/4	26	3	43-3/16	22	45-1/4	16-3/4	30	182T
180	31	14	42-1/4	28	3	47-9/16	22	47-3/4	16-3/4	36	182T
195	33-1/4	31	52-1/2	31	3	50-7/16	22	66-3/4	16-3/4	38	182T
210	34-1/2	31	52-1/2	34	3	54-1/4	22	68	16-3/4	42	182T
225	35-1/2	31	52-1/2	36	3	59	25	69	18	42	184T
245	41	33	62-1/2	40	3	64-5/16	25	76	18	48	213T
270	46-1/2	25	73	44	3	71-11/16	30	73-3/4	21	54	213T
300	48-1/4	25	73	48	3	73-15/16	30	75-1/2	21	54	215T

ALL DIMENSIONS IN INCHES. WEIGHT IN LBS., LESS MOTOR.

STANDARD CONSTRUCTION FEATURES:

All aluminum wheel - Minimum 12 gauge steelhousing with standard inspection door - Lorenized baked powder paint finish - Welded steel construction - Regreasable bearings in cast housing rated at 400,000 hours average life - Extended lube lines - Adjustable pitch drives through 5 hp - All fans factory adjusted to specified fan RPM - Spun all aluminum tiered construction top cap - Birdscreen.

ACCESSORIES

1. DISCONNECT SWITCH
2. ACCESS DOOR

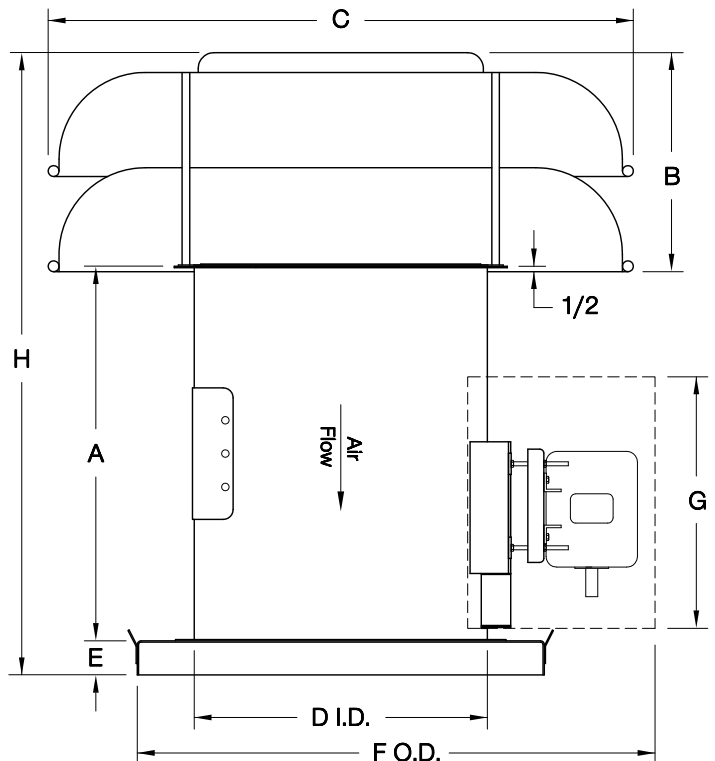
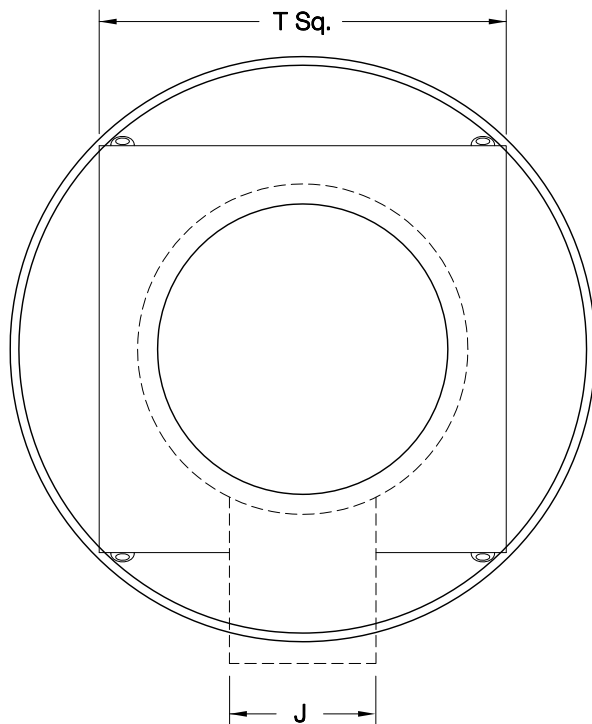

CV011R00