



COOK

SDB

DATE: _____

PROJECT: _____

LOCATION: _____



**Duct Blower
External Belt Drive
Backward Inclined
Centrifugal Wheel**

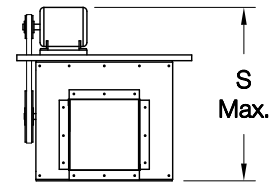
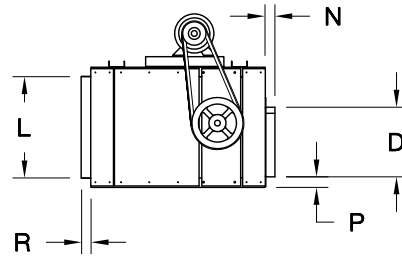
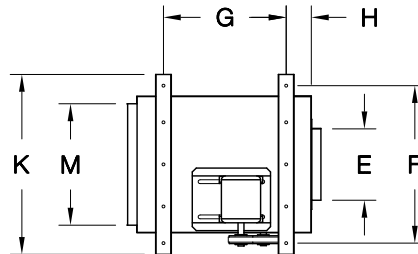
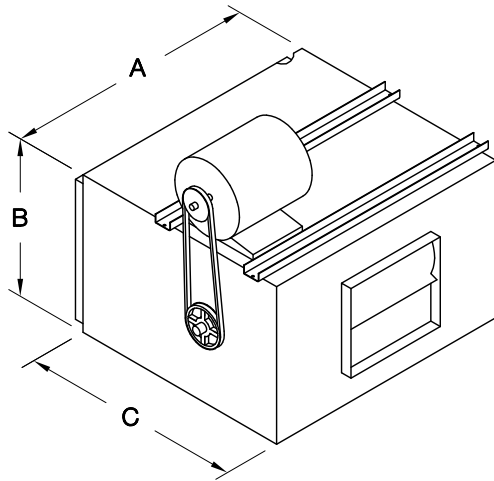

DIMENSION DATA

Size	A	B	C	D O.D.	E O.D.	F	G	H	K	L O.D.	M O.D.	N	P	R	S	Max. HP	Ship Wt.
100	22-3/8	20-1/8	28-1/4	11-3/8	13-1/8	26	13-3/8	3-11/16	28	18-1/8	20-3/8	1-1/4	1-1/4	1-1/4	30-1/16	1	80
120	22-3/8	20-1/8	28-1/4	11-3/8	13-1/8	26	13-3/8	3-11/16	28	18-1/8	20-3/8	1-1/4	1-1/4	1-1/4	32-1/2	1-1/2	80
135	27-1/8	23-3/16	31-1/4	13-7/16	15-5/8	30	16-1/8	3-11/16	32	21-3/16	25-1/8	1-1/4	1-1/4	1-1/4	35-9/16	2	108
150	32-1/2	26-15/16	36-1/4	15-7/8	18-5/8	36	19-1/2	3-11/16	38	24-15/16	30-1/2	1-1/4	1-1/4	1-1/4	39-5/16	3	205
180	41	31-7/8	44-3/4	18-7/8	21-7/8	44	24	3-7/8	46	29-7/8	39	1-1/4	1-1/4	1-1/4	44-1/4	5	400
210	49	40-1/4	44-1/2	24-3/4	24-3/4	50	29-3/8	3-5/8	52	36-1/4	45	1-3/8	2-1/8	1-1/2	52-1/4	5	600
245	53	43-3/4	51-1/16	27-1/4	27-1/4	54	29-1/8	3-5/8	56	39-3/4	49	1-3/8	2-1/8	1-1/2	57-3/8	7-1/2	800

ALL DIMENSIONS IN INCHES. WEIGHTS IN LBS.

STANDARD CONSTRUCTION FEATURES:

Galvanized steel housing – Permanently lubricated ball bearing motors –
Blower is vibration isolated inside housing – Static resistant belts –
American made bearings rated at 200,000 hours average life –
Adjustable pitch drives through 5 hp motor – Corrosion resistant fasteners – Removable side access panel – Horizontal hanging brackets –
All fans factory adjusted to specified fan RPM.

ACCESSORIES

1. SLIDE OUT FILTER BOX
2. NEMA 1 DISCONNECT SWITCH
3. BELT GUARD
4. AUTO BACKDRAFT DAMPER

QTY	MARK	CATALOG NUMBER	FAN INFORMATION			MOTOR INFORMATION					ACCESSORIES						
			CFM	SP	RPM	HP	VOLTS	HZ	PH	TYPE							

LARGEST MOTOR SHIPPED MOUNTED: ODP (OPEN DRIP-PROOF) 5 HP; 2 SP (2 SPEED) 2 HP; X-PRF (EXPLOSION PROOF) 2 HP; TEFC (TOTALLY ENCLOSED FAN COOLED) 2 HP.

DB001R04