



# COOK

# DBX

DATE: \_\_\_\_\_  
 PROJECT: \_\_\_\_\_  
 LOCATION: \_\_\_\_\_



**Duct Blower**  
**External Belt Drive**

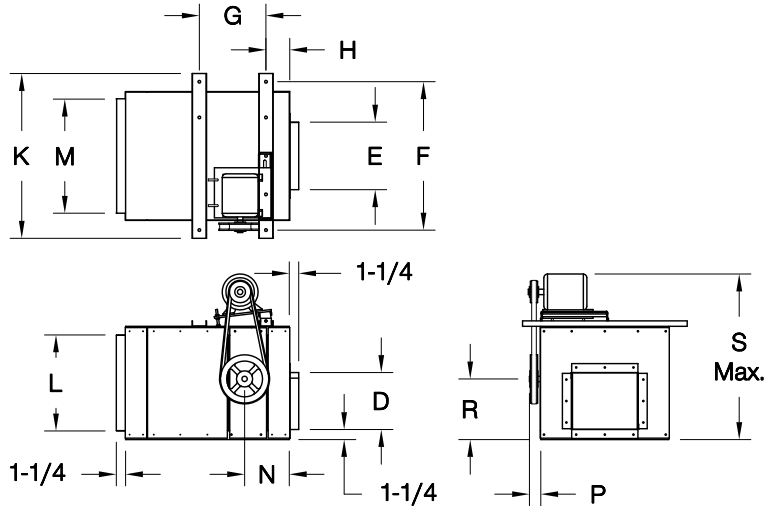
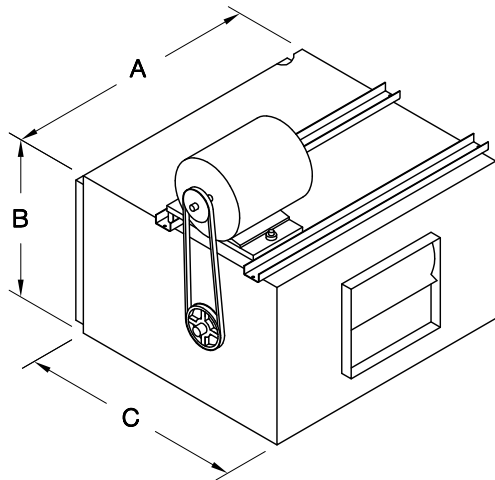

**DIMENSION DATA**

Size	A	B	C	D O.D.	E O.D.	F	G	H	K	L O.D.	M O.D.	N	P	R	S	Ship Weight
DBX-8	18-1/8	15-7/16	23	7-7/8	9-1/4	21	9-5/8	3-5/16	23	13-7/16	16-1/8	6-3/8	2-3/8	8-1/4	24-9/16	53
DBX-9	21-1/8	18-1/8	25-3/4	10-5/16	11-7/8	24	11-3/4	3-11/16	26	16-1/8	19-1/8	7-3/16	2-3/8	9-7/8	27-1/4	70
DBX-10	22-3/8	20-1/8	28-1/4	11-3/8	13-1/8	26	13-3/8	3-11/16	28	18-1/8	20-3/8	7-15/16	4	10-7/8	30-1/16	80
DBX-13	27-1/8	23-3/16	31-1/4	13-7/16	15-5/8	30	16-1/8	3-11/16	32	21-3/16	25-1/8	9-1/8	4	12-23/32	35-9/16	108
DBX-15	32-1/2	26-15/16	36-1/4	15-7/8	18-5/8	36	19-1/2	3-11/16	38	24-15/16	30-1/2	10-1/2	4	14-27/32	39-5/16	205
DBX-18	41	31-7/8	44-3/4	18-7/8	21-7/8	44	24	3-7/8	46	29-7/8	39	12-3/8	4	17-9/16	44-1/4	400

ALL DIMENSIONS IN INCHES. WEIGHTS IN LBS.

**STANDARD CONSTRUCTION FEATURES:**

Galvanized steel housing – Permanently lubricated ball bearing motors – Blower is vibration isolated from the housing – Static resistant belts – Bearings rated at 200,000 hours average life – Adjustable pitch drives through 5 hp motor – Corrosion resistant fasteners – Removable side access panel – Motor out of the airstream – Horizontal hanging brackets – All fans factory adjusted to specified fan RPM.

**ACCESSORIES**

1. SLIDE-OUT FILTER BOX
2. NEMA 1 DISCONNECT SWITCH
3. BELT GUARD
4. AUTO BACKDRAFT DAMPER

QTY	MARK	CATALOG NUMBER	FAN INFORMATION			MOTOR INFORMATION					ACCESSORIES					
			CFM	SP	RPM	HP	VOLTS	HZ	PH	TYPE						

**LARGEST MOTOR SHIPPED MOUNTED:** ODP (OPEN DRIP-PROOF) 5 HP; 2 SP (2 SPEED) 2 HP; X-PRF (EXPLOSION PROOF) 2 HP; TEFC (TOTALLY ENCLOSED FAN COOLED) 2 HP.

**DB003R05**