

DATE: _____
 PROJECT: _____
 LOCATION: _____

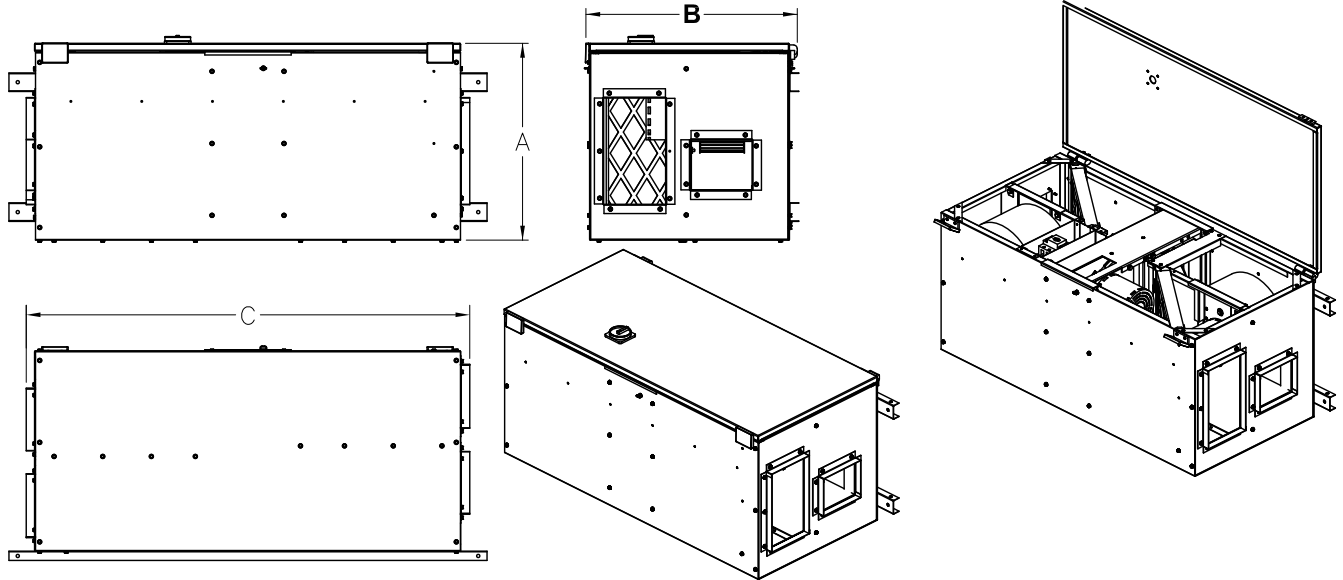

Energy Recovery Ventilator Internal Direct Drive



DIMENSION DATA

Size	A	B	C	Wheel Diameter	Weight Inc. Motors	Filters (Qty)/Size
ERV-500	22	23-13/16	50-3/32	18	285	(2)/16 X 20
ERV-1000	28-1/4	28-13/16	50-3/32	24	344	(2)/16 X 25

ALL DIMENSIONS IN INCHES. WEIGHTS IN LBS.

STANDARD CONSTRUCTION FEATURES:

Energy recovery wheel constructed of fluted synthetic media containing water selective molecular sieve desiccant - Cassette assembly slides out for easy access and consists of the energy recovery wheel, drive motor, and drive components - Ventilator cabinet consisting of a minimum 18 gauge galvanized steel housing - Cabinet internally lined with 1" thick, 3 lb. density, FSK insulation - Cabinet constructed with a hinged door that allows easy access to all internal components - Two SWSI forward curved steel blowers - Standard size 2" thick, 30% efficient filters in supply and exhaust air streams - All electrical components pre-wired for single point power connection - Interlock disconnect on hinged access door

QTY	MARK	CATALOG NUMBER	ACCESSORIES

ACCESSORIES

1. FAN SPEED CONTROLS - PREWIRED
2. LORENIZED FINISH
3. GRAVITY INTAKE DAMPERS
4. MOTORIZED INTAKE DAMPERS
5. LOW LEAKAGE INTAKE DAMPERS
6. INSULATED MOTORIZED INTAKE DAMPERS
7. DAMPERS FOR FIELD MOUNTING IN EXHAUST DUCTWORK
8. DAMPERS FOR FIELD MOUNTING IN SUPPLY DUCTWORK
9. DOUBLE WALL CONSTRUCTION
10. SENSIBLE ONLY WHEELS
11. ADJUSTABLE PURGE SECTION
12. CEILING MOUNT ISOLATORS
13. FIELD INSTALLED DISCONNECT SWITCHES
14. LOW PROFILE MOUNTING FEET
15. 24 VOLT CONTROL PANEL
16. DIRTY FILTER SENSORS*
17. ROTATION SENSOR*
18. ECONOMIZER MODE WITH TEMPERATURE SENSOR*
19. ECONOMIZER MODE WITH ENTHALPY SENSOR*
20. ON/OFF FROST CONTROL*
21. EXHAUST ONLY FROST CONTROL*
22. FIELD INSTALLED PREHEAT FROST CONTROL

*REQUIRES 24 VOLT CONTROL PANEL