

DATE: _____
 PROJECT: _____
 LOCATION: _____



Air Supply Package
Forward Curve - Belt Drive
Bottom Discharge
Roof Mounted

DIMENSION DATA

Size	A Sq.	B	C	D	E	F	T Sq.	H x W Bottom Discharge Opening	Filters	
									Qty	Size
90	33-1/8	26-1/2	10-1/2	6-7/32	7	3	24-1/8	10-1/8 x 11-9/16	4	10-1/4 x 19-3/4
100	38-1/2	30	12-1/4	7-5/8	8-7/16	3	28-1/8	11-1/4 x 12-7/8	4	12 x 24
120	42-1/2	33-1/4	16-1/2	8-3/8	8-3/4	3	32-1/8	13-5/16 x 15-3/8	4	16 x 28
150	45-3/4	36-1/4	16-1/2	6-7/8	6-5/16	3	32-1/8	15-3/4 x 18-3/8	4	16 x 28
180	55-3/4	40-1/4	22-3/4	7-1/4	5-5/16	3	36-1/8	18-3/4 x 21-5/8	4	20 x 32
200	68	47-1/4	29	11-11/16	10-5/8	3	48-1/8	24-7/8 x 24-3/4	4	27-3/4 x 44

Size	Material Gauges		Roof Open. Sq.*	Ship Wt.
	Base	Housing		
90	16	18	19-1/2	230
100	16	18	23-1/2	250
120	16	18	27-1/2	290
150	16	18	27-1/2	330
180	16	18	31-1/2	500
200	16	18	43-1/2	750

ALL DIMENSIONS IN INCHES. WEIGHTS IN LBS., LESS MOTOR.
 *ROOF OPENING SIZE FOR CURBS SUPPLIED BY COOK ONLY.

STANDARD CONSTRUCTION FEATURES:

DWDI blower mounted in a totally enclosed heavy gauge galvanized cabinet - Galvanized intake hood with 1" aluminum permanent washable filters - Permanently lubricated ball bearings motor - Adjustable pitch drives through 5 HP - Vibration isolators - Corrosion resistant fasteners - All fans factory adjusted to specified fan RPM.

ACCESSORIES

- GRAVITY INTAKE DAMPER
- MOTORIZED INTAKE DAMPER
- DUCT ADAPTER
- RCG GALVANIZED CURB
- RCA ALUMINUM CURB
- LIFTING LUGS/TIE DOWN POINTS
- 2" ALUMINUM FILTERS

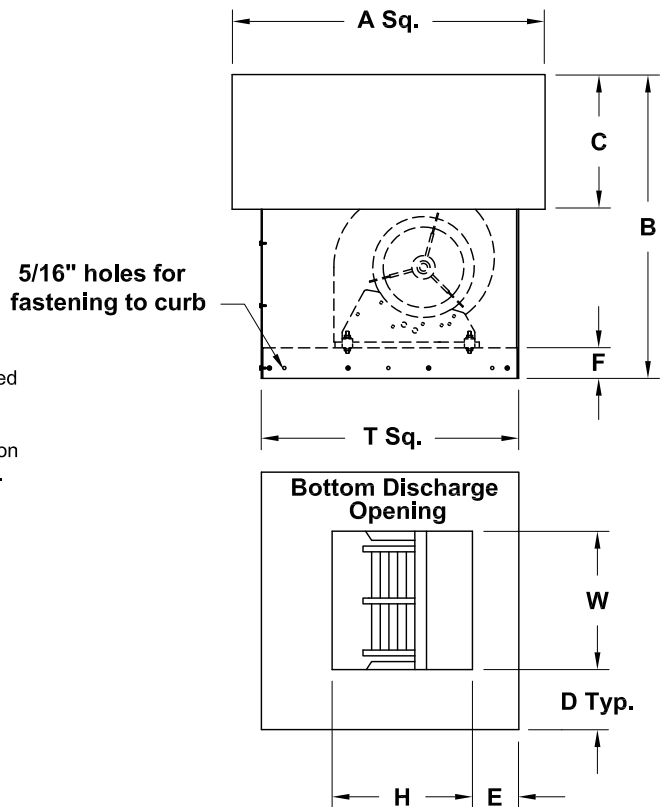

QTY	MARK	CATALOG NUMBER	FAN INFORMATION			MOTOR INFORMATION					ACCESSORIES	
			CFM	SP	RPM	HP	VOLTS	HZ	PH	TYPE		

LARGEST MOTOR SHIPPED MOUNTED: ODP (OPEN DRIP-PROOF) 1 HP (SIZES 90-180), 5 HP (SIZE 200); 2 SP (2 SPEED) NONE (SIZES 90-180), 1-1/2 HP (SIZE 200); TEFC (TOTALLY ENCLOSED FAN COOLED) NONE (SIZES 90-180), 1-1/2 HP (SIZE 200).