



COOK

ASP-T

DATE: _____

PROJECT: _____

LOCATION: _____



**Air Supply Package
Forward Curve-Belt Drive
Side Discharge
Tiered
Roof Mounted**

DIMENSION DATA

Model	A Sq.	B	C	D	E	T Sq.
90ASP-T	30-7/8	30-1/4	13-1/4	5-1/4	3	24-1/8
100ASP-T	34-7/8	32	13-1/4	5-1/4	3	28-1/8
120ASP-T	38-7/8	37-1/2	16-3/4	5-1/4	3	32-1/8
150ASP-T	38-7/8	40	16-3/4	5-1/4	3	32-1/8
180ASP-T	42-7/8	53-1/2	27-1/4	5-1/4	3	36-1/8
200ASP-T	54-7/8	61-3/4	30-3/4	5-3/4	3	48-1/8

Model	H x W Side Discharge Opening	Filters		No. Tiers	Ship Wt.
		Qty	Size		
90ASP-T	10-1/8 x 11-9/16	4	12 x 18-1/4	3	230
100ASP-T	11-1/4 x 12-7/8	4	12 x 22-1/4	3	250
120ASP-T	13-5/16 x 15-3/8	4	15-1/2 x 26-1/4	4	290
150ASP-T	15-3/4 x 18-3/8	4	15-1/2 x 26-1/4	4	330
180ASP-T	18-3/4 x 21-5/8	4	26 x 30-1/4	7	500
200ASP-T	24-7/8 x 24-3/4	4	29-1/2 x 42-1/4	8	750

ALL DIMENSIONS IN INCHES. WEIGHTS IN LBS., LESS MOTOR.

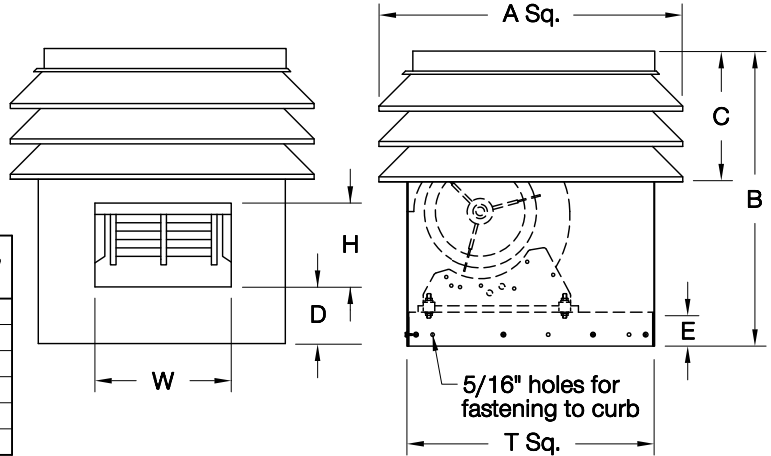

STANDARD CONSTRUCTION FEATURES:

DWDI blower mounted in a totally enclosed 18 gauge cabinet – Heavy gauge extruded aluminum intake hood with 1" permanent washable filters – Permanently lubricated ball bearing motor – Adjustable pitch drives through 5 HP – Corrosion resistant fasteners – All fans factory adjusted to specified fan RPM.

ACCESSORIES

- GRAVITY INTAKE DAMPER
- MOTORIZED INTAKE DAMPER
- DUCT ADAPTER
- RCG GALVANIZED CURB
- RCA ALUMINUM CURB
- FIBERGLASS OR POLYESTER FILTER MEDIA
- SPECIAL

QTY	MARK	CATALOG NUMBER	FAN INFORMATION			MOTOR INFORMATION					ACCESSORIES			
			CFM	SP	RPM	HP	VOLTS	HZ	PH	TYPE				

LARGEST MOTOR SHIPPED MOUNTED: ODP (OPEN DRIP-PROOF) 1 HP (SIZES 90-180), 5 HP (SIZE 200);
2 SP (2 SPEED) NONE (SIZES 90-180), 1-1/2 HP (SIZE 200); **TEFC** (TOTALLY ENCLOSED FAN COOLED)
 NONE (SIZES 90-180), 1-1/2 HP (SIZE 200).

FF202R02