

DATE: _____
 PROJECT: _____
 LOCATION: _____



**Filtered Kitchen Supply
 Packaged Ventilator
 with Filter Box
 Belt Drive**

DIMENSION DATA

Model	A Sq.	B	C	D	E	F	G	H	T Sq.	H x W Bottom Discharge Opening	Roof Opening Sq.*
90KSPB	24-3/16	24	18 x 18-1/4	17-1/4	6-7/32	7	3	26-1/2	24-1/8	10-1/8 x 11-9/16	19-1/2
100KSPB	28-3/16	27	21 x 22-1/4	20-1/4	7-5/8	8-7/16	3	25-3/4	28-1/8	11-1/4 x 12-7/8	23-1/2
120KSPB	32-3/16	32-1/4	26-3/16 x 26-1/2	25-5/8	8-3/8	8-3/4	3	26-1/2	32-1/8	13-5/16 x 15-3/8	27-1/2
150KSPB	32-3/16	37-3/8	31-5/16 X 28-1/2	30-3/4	6-7/8	6-5/16	3	26	32-1/8	15-3/4 x 18-3/8	27-1/2
180KSPB	36-3/16	41-7/16	35-7/16 X 30-1/4	34-13/16	7-1/4	5-5/16	3	26-1/2	36-1/8	18-3/4 x 21-5/8	31-1/2
200KSPB	48-3/16	49-7/16	37-7/16 X 46	36-13/16	11-11/16	12-15/16	3	26-1/4	48-1/8	24-7/8 x 24-3/4	43-1/2

Model	Filters		Box Filters		Material Gauges		Ship Wt.
	Qty	Size	Qty	Size	Base	Housing	
90KSPB	1	17-3/4 x 22-3/4	2	20 x 25 x 2	16	18	183
100KSPB	1	21-3/4 x 27	2	25 x 25 x 2	16	18	218
120KSPB	1	25-3/4 x 34-3/8	6	14 x 25 x 2	16	18	253
150KSPB	2	20-3/4 x 28	3/3	20 x 25 x 2/14 x 25 x 2	16	18	327
180KSPB	2	23-5/8 x 29-3/4	4/4	25 x 25 x 2/14 x 25 x 2	16	18	392
200KSPB	2	25 x 41-3/4	15	16 x 25 x 2	16	18	589

ALL DIMENSIONS IN INCHES. WEIGHTS IN LBS., LESS MOTOR.
 * ROOF OPENING SIZE FOR CURBS SUPPLIED BY COOK ONLY.

STANDARD CONSTRUCTION FEATURES:

DWDI blower mounted in a totally enclosed galvanized cabinet with hooded, filtered intake - Insulated top cap with quick release latches - Permanent, one inch, washable, aluminum filters (fiberglass or polyester media available) - Adjustable pitch drives through 5 H.P. - Vibration isolators - Corrosion resistant fasteners - MERV 8 filters in filter box (MERV 11 available) - All fans factory adjusted to specified fan RPM.

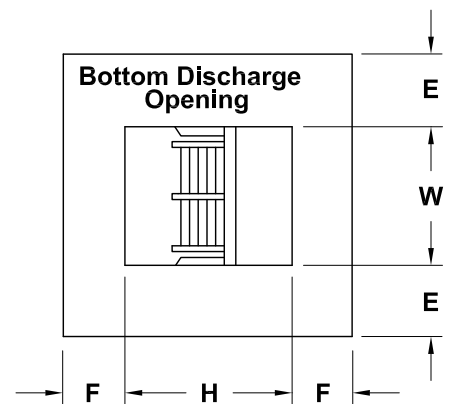

ACCESSORIES

1. COMMON CURB
2. COMMON CURB CAP
3. DUCT ADAPTER
4. RCG GALVANIZED CURB
5. INTAKE DAMPER

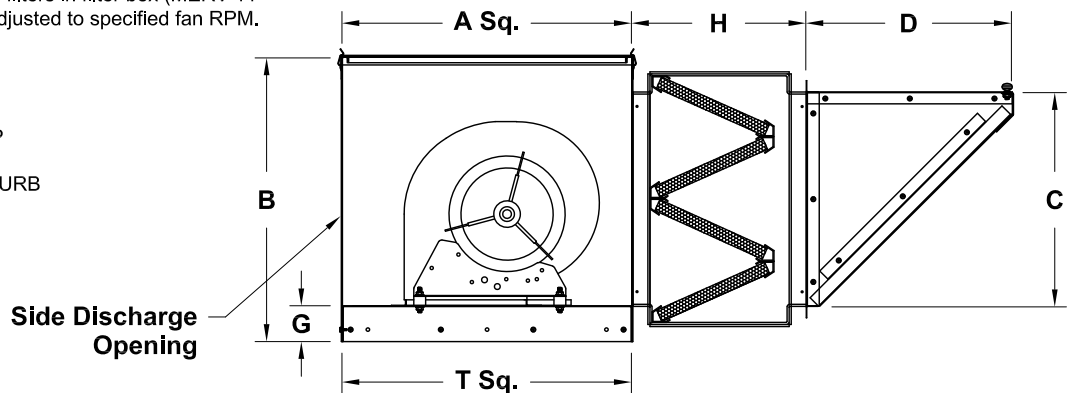

QTY	MARK	CATALOG NUMBER	FAN INFORMATION			MOTOR INFORMATION					ACCESSORIES	
			CFM	SP	RPM	HP	VOLTS	HZ	PH	TYPE		

LARGEST MOTOR SHIPPED MOUNTED: ODP (OPEN DRIP-PROOF) 1 HP (SIZES 90-180), 5 HP (SIZE 200);
 2 SP (2 SPEED) NONE (SIZES 90-180), 1-1/2 HP (SIZE 200); X-PRF (EXPLOSION PROOF) NONE (SIZES 90-180),
 1-1/2 HP (SIZE 200); TEFC (TOTALLY ENCLOSED FAN COOLED) NONE (SIZES 90-180), 1-1/2 HP (SIZE 200).