



COOK

QMX

DATE: _____

PROJECT: _____

LOCATION: _____



**Mixed Flow Inline
Horizontal Mount
Belt Drive
Arrangement 9**

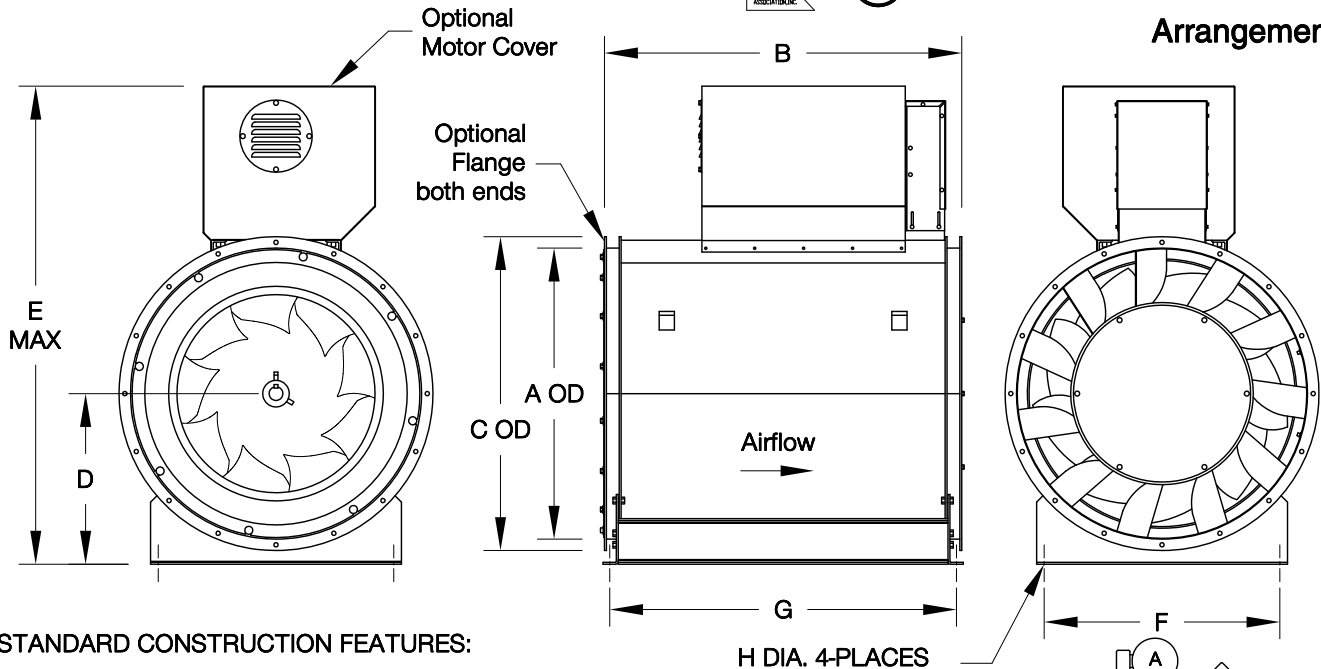

STANDARD CONSTRUCTION FEATURES:

- High efficiency mixed flow wheel – Continuously welded steel housing with Lorenized powder coating –
- Welded aerodynamic straightening vanes – Integral inlet and outlet collars for slip fit duct connections –
- Adjustable motor plate utilizing threaded studs for positive belt tensioning – Heavy duty ball or roller bearings with copper extended lube lines – Belt guard –
- Lifting lugs – Adjustable mounting feet.

**MOTOR POSITION CHART
(View Facing Outlet)**

Mounting positions are field adjustable.

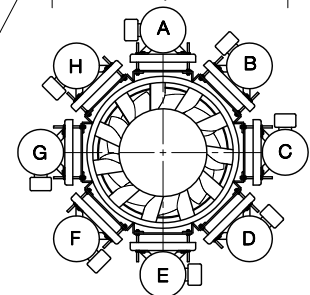

DIMENSION DATA

Size	A	B	C	D	E	F	G	H	Shaft Diameter	Max Motor Frame	Approx. Ship Wt.
90	12-13/16	19-7/8	15-7/8	8-1/2	31-1/4	12-3/8	18-3/8	1/2	1	184T	127
120	17-1/16	24	20-1/16	10-1/2	36-11/16	15-1/2	22-1/2	1/2	1-3/16	213T	186
135	19-1/4	27	22-1/4	12	39-3/8	17-1/2	25-1/2	1/2	1-3/16	213T	253
150	21-3/8	30	24-3/8	13-3/16	42-1/16	18-3/4	28-5/8	1/2	1-3/16	215T	313
165	23-1/2	33	26-1/2	14-5/16	43-5/8	20-13/16	31-5/8	1/2	1-3/16	254T	367
180	25-5/8	35	28-5/8	15-1/2	46-1/4	22-13/16	33-5/8	9/16	1-3/16	254T	416
202	28-3/4	37-1/2	31-3/4	17-1/4	49-15/16	24-1/4	36-1/8	9/16	1-7/16	256T	513
225	31-15/16	41	34-15/16	19	55-13/16	26-15/16	39-5/8	9/16	1-7/16	284T	632
245	34-3/4	44-1/2	37-3/4	20-1/2	59	28-15/16	43-1/8	11/16	1-11/16	286T	744
270	38-5/16	47	41-5/16	22-7/16	62-7/8	31	45-5/8	11/16	1-15/16	286T	873
300	42-1/2	54	45-1/2	24-3/4	68-1/16	33-3/4	52-5/8	11/16	1-15/16	286T	1090
330	46-3/4	58-1/2	49-3/4	27	74-13/16	36-3/4	57-1/8	11/16	2-3/16	324T	1340
365	51-3/4	64	54-3/4	29-13/16	80-1/4	40-1/2	63-3/8	13/16	2-7/16	326T	1770
402	56-15/16	68-1/2	59-15/16	32-11/16	88-5/16	44	67-7/8	13/16	2-15/16	364T	2220
445	63-1/16	74	66-1/16	36	94-7/8	48-1/4	73-3/8	13/16	2-15/16	365T	2730
490	69-3/8	80-1/2	72-3/8	39-7/16	103-3/8	52-3/4	79-7/8	13/16	3-7/16	404T	3330
540	76-7/16	87	79-7/16	43-5/16	110-15/16	58	86-3/8	13/16	3-7/16	404T	3860
600	84-7/8	95-1/2	87-7/8	50	122-1/16	64	94-7/8	13/16	3-7/16	404T	4780

ALL DIMENSIONS IN INCHES. WEIGHTS IN LBS., LESS MOTOR.

TM001R03