

DATE: _____

PROJECT: _____

LOCATION: _____



**Mixed Flow Inline
Horizontal
Direct Drive
Arrangement 4**

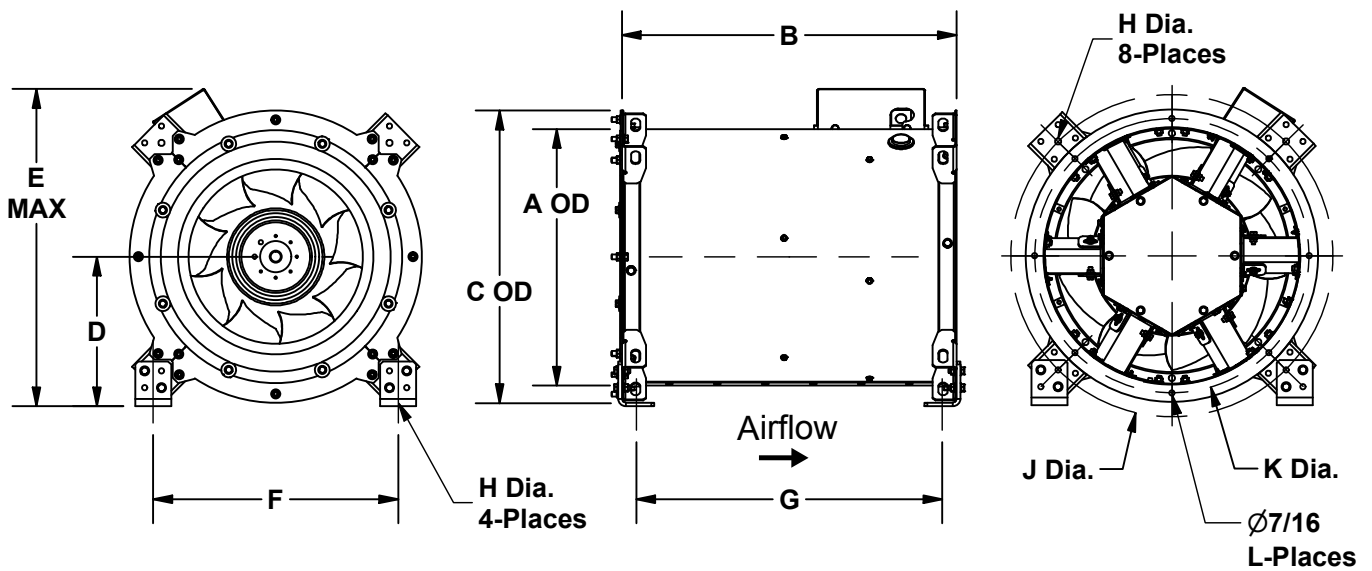

STANDARD CONSTRUCTION FEATURES:

High efficiency mixed flow wheel - Bolted galvanized steel housing and straightening vanes - Integrated lifting lugs - Bolted access door

DIMENSION DATA

Size	A	B	C	D	E	F	G	H	J	K	L	Max Motor Frame	Unit Wt.
90	12 7/8	14 15/16	15 7/8	9 3/8	18 1/4	14 1/4	13 5/8	1/2	18 1/8	14 3/8	8	56	60
120	17 1/8	19 11/16	20 1/16	10 15/16	22 1/2	17 3/8	17 5/16	1/2	22 9/16	18 9/16	8	56	83
135	19 3/16	22 7/8	22 1/4	11 11/16	24 1/2	18 15/16	19 11/16	1/2	24 3/4	20 3/4	8	56	96
150	21 5/16	27 7/8	24 3/8	12 7/16	26 1/2	20 7/16	25 1/2	1/2	26 7/8	22 7/8	8	145T	121
165	23 7/16	29 1/4	26 1/2	13 9/16	28 1/2	22 1/8	26 7/8	1/2	29 1/4	25	8	145T	137
180	25 9/16	31 5/8	28 5/8	14 5/8	28 15/16	23 5/8	29 1/4	9/16	31 3/8	27 1/8	8	184T	158
202	28 11/16	35 1/16	31 3/4	16 1/8	32	25 13/16	32 11/16	9/16	34 1/2	30 1/4	8	184T	207
225	31 15/16	38 11/16	34 15/16	17 3/4	35 3/16	28 1/4	36 5/16	9/16	37 15/16	33 7/16	8	215T	271
245	34 3/4	41 7/16	38 3/4	21 7/16	40 13/16	31 5/8	38 15/16	11/16	42 3/4	36 1/4	16	215T	338

ALL DIMENSIONS IN INCHES. WEIGHTS IN LBS., LESS MOTOR.