



COOK

AFB-H

DATE: _____

PROJECT: _____

LOCATION: _____



**Tube Axial Fan
Horizontal Ceiling Mount
High Temperature Construction
Belt Drive/Arrangement 9**

DIMENSION DATA

Size	A	B	C	D	E	F	G	H	J	K	L	M
12	12-7/8	15-5/8	14-5/8	12 Ga.	22	5/16	6	24-5/8	15	15	3-1/2	3/8
14	14-7/8	17-5/8	16-5/8	12 Ga.	22	5/16	6	25-5/8	17	15	3-1/2	3/8
16	16-7/8	19-5/8	18-5/8	12 Ga.	25	5/16 x 5/8	6	30-1/8	19	18	3-1/2	3/8
18	18-7/8	21-5/8	20-5/8	12 Ga.	25	5/16 x 5/8	6	31-1/8	21	18	3-1/2	3/8
20	20-7/8	23-5/8	22-3/8	12 Ga.	31	5/16 x 5/8	6	32-1/8	23	24	3-1/2	3/8
24	24-7/8	29-1/8	26-7/8	10 Ga.	31	7/16 x 3/4	6	39-7/8	27	23	4	3/8
28	28-7/8	33-1/8	30-7/8	10 Ga.	31	7/16 x 3/4	6	41-7/8	31	23	4	3/8
32	33	37-1/4	35	10 Ga.	34	7/16 x 3/4	6	45-1/4	35-1/2	25-1/2	4-1/4	7/16
36	37	41-3/8	39	10 Ga.	34	7/16 x 3/4	6	47-1/4	39-1/8	25-1/2	4-1/4	7/16

Size	ODP Max. Mtr. Frame	Ship Wt. less Mtr.
12	145T	97
14	182T	104
16	182T	132
18	184T	149
20	184T	182
24	213T	244
28	215T	278
32	254T	373
36	256T	408

ALL DIMENSIONS IN INCHES. WEIGHTS IN LBS.

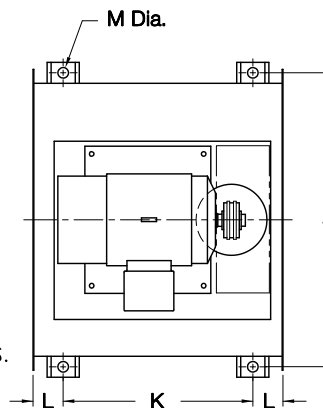

STANDARD CONSTRUCTION FEATURES:

High temperature steel construction
 500°F maximum airstream temperature –
 Fabricated steel prop – Minimum 12 ga.
 steel housing – Extended lube lines –
 Regreasable bearings in cast pillow
 block housing with high temperature
 grease – Bearing heat sinks – Heat
 slinger – Motor heat deflection plate.

ACCESSORIES

1. INLET/OUTLET GUARD
2. INLET/OUTLET COMPANION FLANGE
3. VIBRATION ISOLATORS
4. INLET BELL
5. INLET/OUTLET CONE
6. ACCESS DOOR
7. VANE SECTION
8. MOTOR COVER
9. BELT GUARD

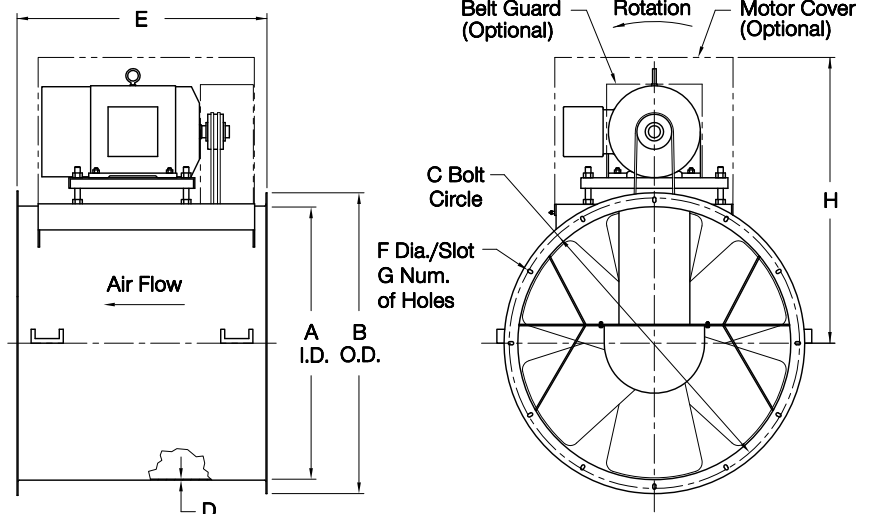

LARGEST MOTOR SHIPPED MOUNTED: ODP (OPEN DRIP-PROOF) 25 HP; 2 SP (2 SPEED) 20 HP;
 X-PRF (EXPLOSION PROOF) 20 HP; TEFC (TOTALLY ENCLOSED FAN COOLED) 20 HP.

VA051R02