



COOK

AFB-H

DATE: _____

PROJECT: _____

LOCATION: _____



**Tube Axial Fan
Downblast Floor Mount
High Temperature Construction
Belt Drive/Arrangement 9**

DIMENSION DATA

Size	A	B	C	D	E	F	G	H	J	K	L
12	12-7/8	15-5/8	14-5/8	12 Ga.	22	5/16	6	24-5/8	18-1/16	3/8	12-3/4
14	14-7/8	17-5/8	16-5/8	12 Ga.	22	5/16	6	25-5/8	20-1/16	3/8	14-3/16
16	16-7/8	19-5/8	18-5/8	12 Ga.	25	5/16 x 5/8	6	30-1/8	22-1/16	3/8	15-5/8
18	18-7/8	21-5/8	20-5/8	12 Ga.	25	5/16 x 5/8	6	31-1/8	24-1/16	3/8	17
20	20-7/8	23-5/8	22-3/8	12 Ga.	31	5/16 x 5/8	6	32-1/8	26-5/16	3/8	18-5/8
24	24-7/8	29-1/8	26-7/8	10 Ga.	31	7/16 x 3/4	6	39-7/8	30-13/16	3/8	21-3/4
28	28-7/8	33-1/8	30-7/8	10 Ga.	31	7/16 x 3/4	6	41-7/8	34-13/16	3/8	24-5/8
32	33	37-1/4	35	10 Ga.	34	7/16 x 3/4	6	45-1/4	39-15/16	7/16	28-1/4
36	37	41-3/8	39	10 Ga.	34	7/16 x 3/4	6	47-1/4	43-15/16	7/16	31-1/16

Size	ODP Max. Mtr. Frame	Ship Wt. less Mtr.
12	145T	88
14	182T	95
16	182T	123
18	184T	140
20	184T	173
24	213T	235
28	215T	269
32	254T	354
36	256T	393

ALL DIMENSIONS IN INCHES. WEIGHTS IN LBS.

STANDARD CONSTRUCTION FEATURES:

High temperature steel construction 500°F maximum airstream temperature – Fabricated steel prop – Minimum 12 ga. steel housing – Extended lube lines – Regreasable bearings in cast pillow block housing with high temperature grease – Bearing heat sinks – Heat slinger – Motor heat deflection plate.

ACCESSORIES

1. INLET/OUTLET GUARD
2. INLET/OUTLET COMPANION FLANGE
3. VIBRATION ISOLATORS
4. INLET BELL
5. INLET/OUTLET CONE
6. ACCESS DOOR
7. VANE SECTION
8. MOTOR COVER
9. BELT GUARD
10. BOMBAY DOORS

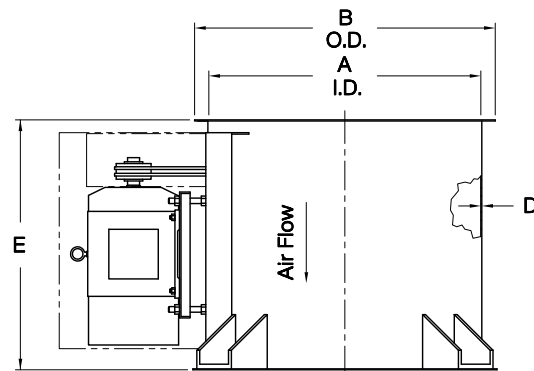
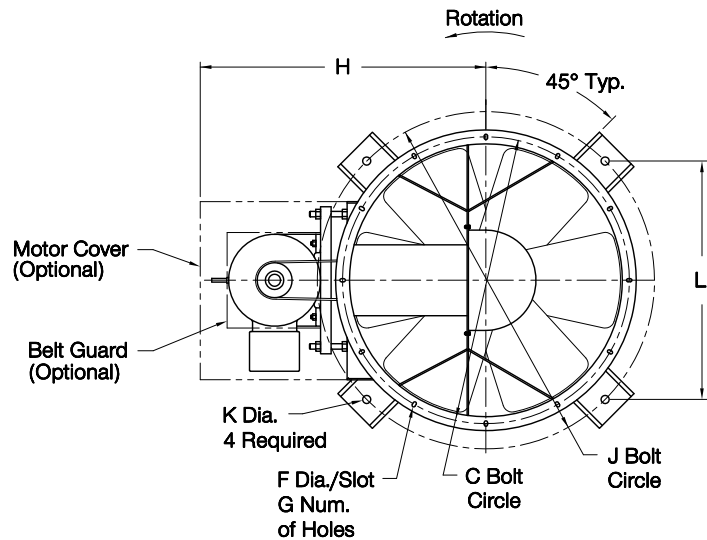

LARGEST MOTOR SHIPPED MOUNTED: ODP (OPEN DRIP-PROOF) 25 HP; 2 SP (2 SPEED) 20 HP; X-PRF (EXPLOSION PROOF) 20 HP; TEFC (TOTALLY ENCLOSED FAN COOLED) 20 HP.

VA054R02