



COOK

AFB-H

DATE: _____

PROJECT: _____

LOCATION: _____



**Tube Axial Fan
Vertical Wall Mount
High Temperature Construction
Belt Drive/Arrangement 9**

DIMENSION DATA

Size	A	B	C	D	E	F	G	H	J	K	L	M	N
12	12-7/8	15-5/8	14-5/8	12 Ga.	22	5/16	6	24-5/8	9-3/4	20-1/8	15/16	16	6
14	14-7/8	17-5/8	16-5/8	12 Ga.	22	5/16	6	25-5/8	10-3/4	20-1/8	15/16	18	7
16	16-7/8	19-5/8	18-5/8	12 Ga.	25	5/16 x 5/8	6	30-1/8	11-3/4	23-1/8	15/16	20	8
18	18-7/8	21-5/8	20-5/8	12 Ga.	25	5/16 x 5/8	6	31-1/8	12-3/4	23-1/8	15/16	22	9
20	20-7/8	23-5/8	22-3/8	12 Ga.	31	5/16 x 5/8	6	32-1/8	14	29-1/8	15/16	24-1/2	10-1/4
24	24-7/8	29-1/8	26-7/8	10 Ga.	31	7/16 x 3/4	6	39-7/8	16	29-1/8	15/16	28-1/2	12-1/4
28	28-7/8	33-1/8	30-7/8	10 Ga.	31	7/16 x 3/4	6	41-7/8	18	29-1/8	15/16	32-1/2	14-1/4
32	33	37-1/4	35	10 Ga.	34	7/16 x 3/4	6	45-1/4	20-1/8	32-1/8	15/16	36-5/8	16-5/16
36	37	41-3/8	39	10 Ga.	34	7/16 x 3/4	6	47-1/4	22-1/8	32-1/8	15/16	40-5/8	18-5/16

Size	P	ODP Max. Mtr. Frame	Material Gauge	Ship Wt. less Mtr.
12	5/16	145T	10	96
14	5/16	182T	10	105
16	5/16	182T	10	133
18	5/16	184T	10	152
20	5/16	184T	10	189
24	7/16	213T	10	255
28	7/16	215T	10	293
32	7/16	254T	10	384
36	7/16	256T	7	423

ALL DIMENSIONS IN INCHES. WEIGHTS IN LBS.

STANDARD CONSTRUCTION FEATURES:

High temperature steel construction 500°F maximum airstream temperature – Fabricated steel prop – Minimum 12 ga. steel housing – Extended lube lines – Regreasable bearings in cast pillow block housing with high temperature grease – Bearing heat sinks – Heat slinger – Motor heat deflection plate.

ACCESSORIES

1. INLET/OUTLET GUARD
2. INLET/OUTLET COMPANION FLANGE
3. VIBRATION ISOLATORS
4. INLET BELL
5. INLET/OUTLET CONE
6. ACCESS DOOR
7. VANE SECTION
8. MOTOR COVER
9. BELT GUARD
10. BOMBAY DOORS

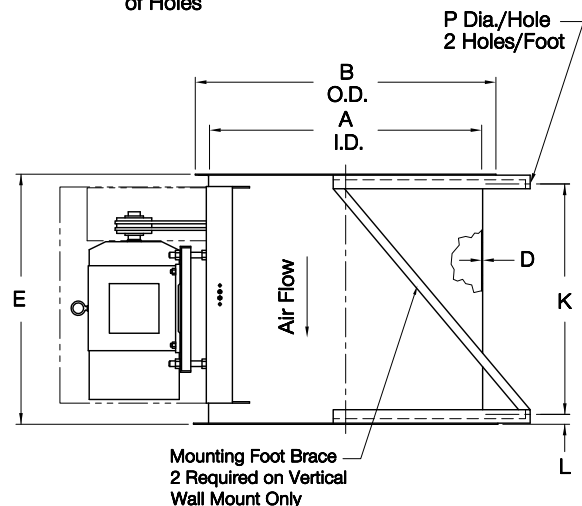
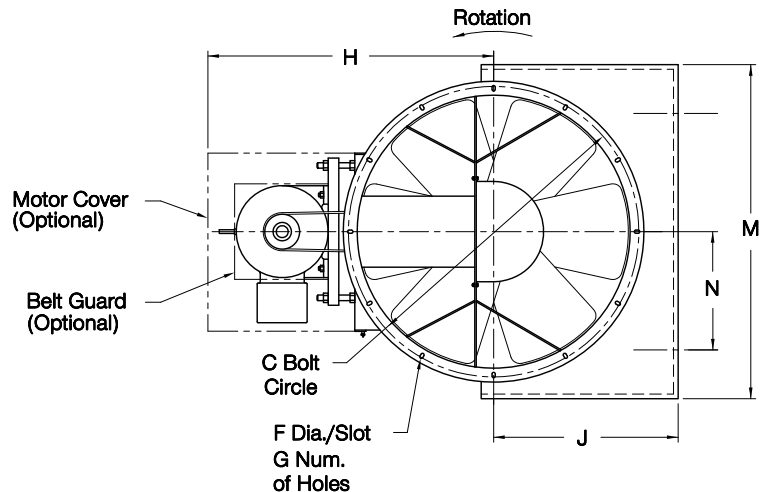

LARGEST MOTOR SHIPPED MOUNTED: ODP (OPEN DRIP-PROOF) 25 HP; 2 SP (2 SPEED) 20 HP; X-PRF (EXPLOSION PROOF) 20 HP; TEFC (TOTALLY ENCLOSED FAN COOLED) 20 HP.

VA056R02