



# COOK

# Roof Exhauster AFB-H

MARK: \_\_\_\_\_

PROJECT: \_\_\_\_\_

DATE: \_\_\_\_\_



Tube Axial Fan  
High Temperature Construction  
Roof Exhauster  
Belt Drive  
Arrangement 9

### DIMENSION DATA

Size	A	B	T Sq.	ODP Max. Mtr. Frame	Ship Wt. less Mtr.
12	36	35-5/8	22	145T	164
14	36	36-5/8	22	182T	171
16	39	43-1/8	26	182T	213
18	47	45-1/8	28	184T	239
20	54	50-1/8	30	184T	325
24	54	57-7/8	36	213T	387
28	54	62-7/8	42	215T	457
32	63	66-1/4	42	254T	589
36	63	71-1/4	48	256T	653

ALL DIMENSIONS IN INCHES. WEIGHTS IN LBS.

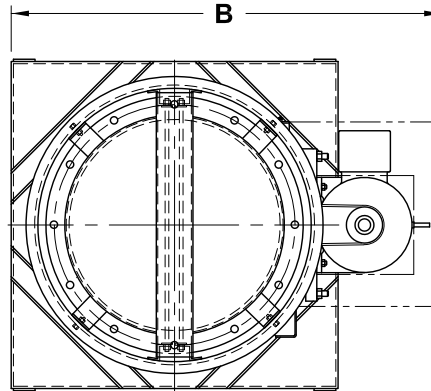

### STANDARD CONSTRUCTION FEATURES:

High temperature steel construction 500°F maximum airstream temperature - Fabricated steel prop - Minimum 12 ga. steel housing - Extended lube lines - Regreasable bearings in cast pillow block housing with high temperature grease - Bearing heat sinks - Heat slinger - Motor heat deflection plate - Integral lifting lugs.

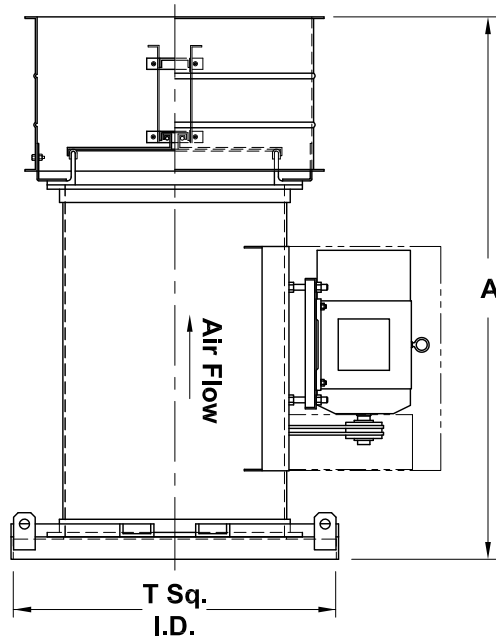

### ACCESSORIES

1. INLET/OUTLET GUARD
2. INSPECTION DOOR
3. MOTOR COVER
4. HUB COVER
5. BOMBAY DOORS (N/A 12 & 14)

QTY	MARK	CATALOG NUMBER	FAN INFORMATION			MOTOR INFORMATION					ACCESSORIES						
			CFM	SP	RPM	HP	VOLTS	HZ	PH	TYPE							

LARGEST MOTOR SHIPPED MOUNTED: ODP (OPEN DRIP-PROOF) 25 HP; 2 SP (2 SPEED) 20 HP;  
X-PRF (EXPLOSION PROOF) 20 HP; TEFC (TOTALLY ENCLOSED FAN COOLED) 20 HP.