



COOK

VAB

DATE: _____

PROJECT: _____

LOCATION: _____



Fixed Pitch Vane Axial Uplblast Floor Mount Belt Drive Arrangement 9

DIMENSION DATA

Size	A	B	C	D	E	F	G	H	J	K	L
12	12	14-3/4	13-3/8	12 Ga.	20	5/16	6	21	17-1/4	3/8	12-3/16
14	14	16-3/4	15-1/2	12 Ga.	23	5/16	6	24	19-1/4	3/8	13-5/8
18	18	21-1/4	19-3/4	12 Ga.	29	7/16 x 13/16	12	27-1/4	23-1/4	3/8	16-7/16
21	21	24-1/4	22-3/4	12 Ga.	31	7/16 x 13/16	12	31-1/2	26-1/4	3/8	18-9/16
26	26	30-5/16	28	10 Ga.	32	7/16 x 13/16	12	34-1/2	31-3/8	3/8	22-3/16
29	29	33-5/16	31	10 Ga.	36	7/16 x 13/16	12	40-1/2	35-3/8	7/16	25
36	36	40-5/16	38	10 Ga.	42	9/16 x 13/16	16	45-1/2	43-3/8	7/16	30-11/16
42	42	46-5/16	44-3/8	10 Ga.	50	9/16 x 13/16	16	50-1/2	48-3/8	7/16	34-3/16
48	48	53-5/16	50-1/2	10 Ga.	56	9/16 x 13/16	16	54	56-3/8	7/16	39-7/8
54	54	59-7/16	56-1/2	7 Ga.	62	9/16 x 13/16	16	59-1/2	62-1/2	7/16	44-3/16
60	60	65-7/16	63-1/4	7 Ga.	69	9/16 x 13/16	16	65	68-1/2	7/16	48-7/16

Size	ODP Max. Mtr. Frame	Ship Wt. less Mtr.
12	184T	86
14	184T	106
18	215T	186
21	256T	236
26	256T	346
29	284T	469
36	286T	689
42	326T	909
48	364T	1141
54	365T	1741
60	405T	1891

ALL DIMENSIONS IN INCHES. WEIGHTS IN LBS.

STANDARD CONSTRUCTION FEATURES:

All aluminum cast prop - Minimum 12 ga.
 Lorenized steel housing with integral
 straightening vanes - Extended lube
 lines - Regreasable bearings in a cast
 iron housing.

ACCESSORIES

1. INLET/OUTLET GUARD
2. INLET/OUTLET COMPANION FLANGE
3. VIBRATION ISOLATORS
4. INLET BELL
5. INLET/OUTLET CONE
6. INSPECTION DOOR
7. SOUND MUFFLER
8. MOTOR COVER
9. HUB COVER
10. BELT GUARD

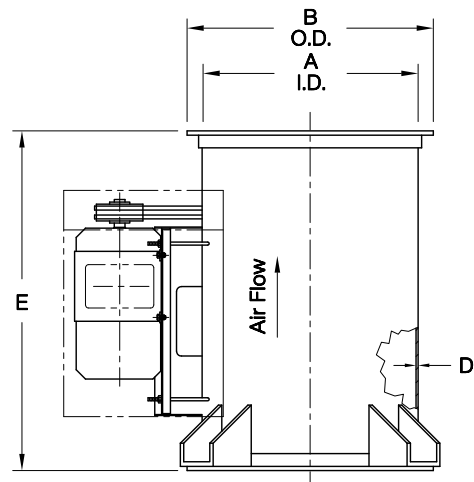
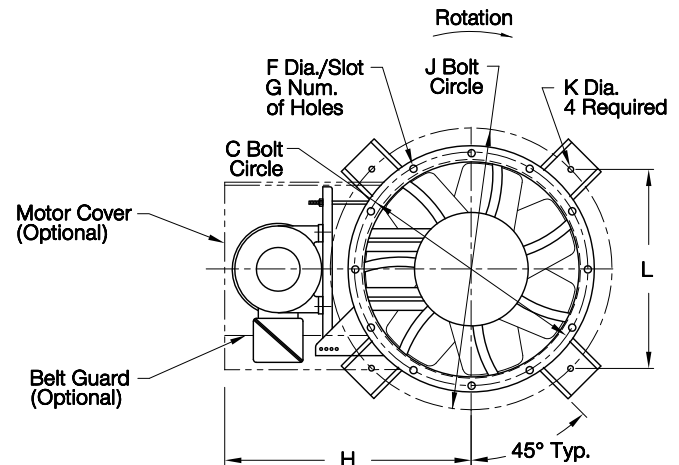

LARGEST MOTOR SHIPPED MOUNTED: ODP (OPEN DRIP-PROOF) 25 HP; 2 SP (2 SPEED) 20 HP;
 X-PRF (EXPLOSION PROOF) 20 HP; TEFC (TOTALLY ENCLOSED FAN COOLED) 20 HP.

VA123R01