

DATE: \_\_\_\_\_  
 PROJECT: \_\_\_\_\_  
 LOCATION: \_\_\_\_\_

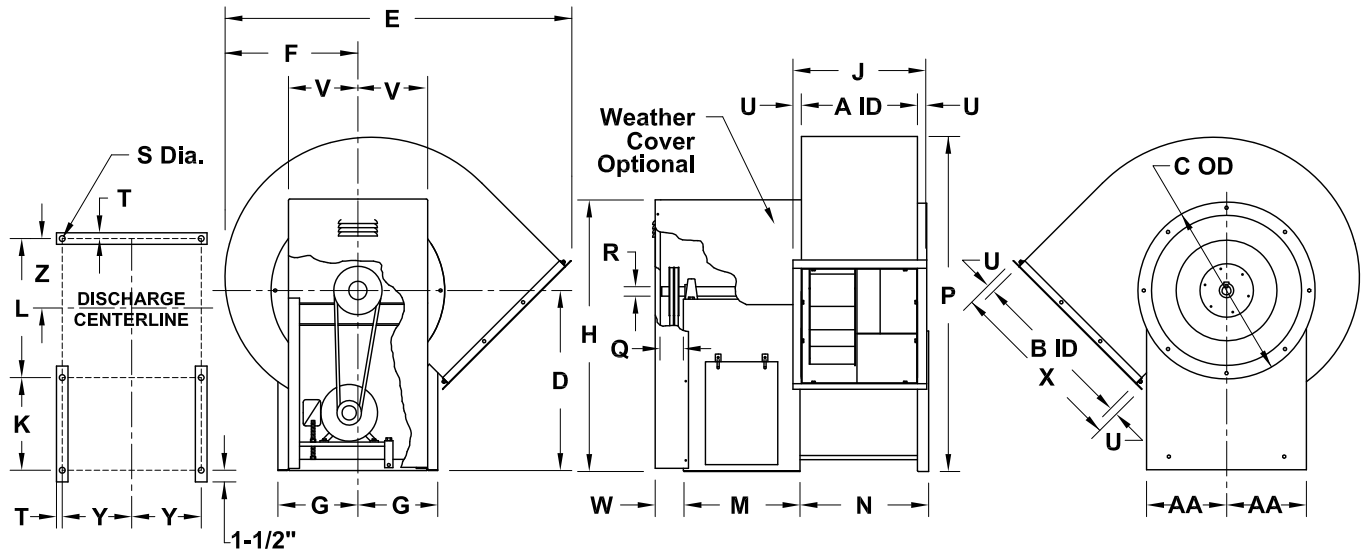

**Flat Blade Centrifugal Blower  
 Clockwise Top Angular Down  
 Arrangement 10, Class II**



### DIMENSION DATA

Size	A	B	C	D	E	F	G	H	J	K	L	M	N
120	9-3/16	13-1/8	16-1/8	22	30-1/2	10-11/16	10-3/8	30-1/4	12-3/8	18	12-5/16	21-1/8	11-1/4
135	10-5/16	14-3/4	17-5/8	22	33-5/16	12	10-3/8	31	13-1/2	18	13-7/16	21-1/8	12-3/8
150	11-7/16	16-7/16	19-1/8	22	36-13/16	13-5/16	10-7/8	32	14-5/8	18	14-9/16	21-1/8	13-1/2
165	12-5/8	18-1/16	21-3/16	24	40	14-5/8	13	35	15-13/16	22-1/8	16-1/8	25-1/4	15-1/16
180	13-3/4	19-11/16	22-11/16	24	43-3/8	15-15/16	13	35-1/2	16-15/16	22-1/8	17-1/4	25-1/4	16-3/16
195	14-15/16	21-5/16	24-3/16	24-1/4	45-15/16	17-1/4	13-3/4	36-1/4	18-3/16	22-1/8	18-1/2	25-1/4	17-3/8
210	16-1/16	23	25-15/16	25-3/8	50-1/16	18-5/8	13-3/4	39	19-5/16	22-1/8	19-5/8	25-1/4	18-1/2
225	17-3/16	24-5/8	27-7/16	27	52-15/16	19-15/16	13-7/8	41	20-7/16	22-1/8	20-7/8	25-1/4	19-3/4
245	18-3/4	26-13/16	29-7/16	29-5/8	57-3/8	21-11/16	14-15/16	44-5/8	23	24-1/8	22-5/16	27-5/16	21-5/16
270	20-5/8	29-9/16	31-15/16	32-3/8	62-11/16	23-15/16	15-7/16	48-7/8	24-7/8	24-1/8	24-11/16	27-5/16	23-11/16
300	22-15/16	32-13/16	34-15/16	35-5/8	69-7/16	26-9/16	16-1/16	53-5/8	27-3/16	26	27-3/16	29-3/16	26-3/16
330	25-1/4	36-1/8	37-15/16	38-7/8	76-1/4	29-1/4	17-5/8	58-3/8	29-7/16	26	29-9/16	29-3/16	28-9/16
365	27-7/8	39-15/16	41-7/16	42-3/4	83-15/16	32-3/16	18-13/16	64-1/4	32-1/16	26	32-9/16	29-1/4	31-7/16

Size	P	Q	R	S	T	U	V	W	X	Y	Z	AA	Max Mtr Frame	Ship Wt.	
														CPS	CPA
120	34-5/16	3	1-7/16	9/16	3/4	1-5/8	9	4	16-5/16	9-5/8	5-9/16	10-1/2	215T	374	303
135	35-13/16	3	1-7/16	9/16	3/4	1-5/8	9	4	17-15/16	9-5/8	6-1/8	10-7/16	215T	391	312
150	37-3/8	3	1-7/16	9/16	3/4	1-5/8	9-1/2	4	19-5/8	10-1/8	6-11/16	10-15/16	256T	434	344
165	40-7/8	3	1-7/16	9/16	3/4	1-5/8	11-1/4	4	21-1/4	12-1/4	7-5/8	13-1/16	256T	537	435
180	42-3/8	3	1-11/16	9/16	3/4	1-5/8	11-1/4	4	22-7/8	12-1/4	8-3/16	13-1/16	256T	605	467
195	44-1/8	3	1-11/16	9/16	3/4	1-5/8	12	4	24-1/2	13	8-13/16	13-7/8	256T	657	503
210	46-13/16	4	1-11/16	9/16	3/4	1-5/8	12	5	26-3/16	13	9-3/8	13-7/8	256T	696	527
225	50	4	1-11/16	9/16	3/4	1-5/8	12-1/16	5	27-13/16	13-1/8	10-1/16	14-1/8	256T	783	595
245	54-5/8	4	1-15/16	11/16	1	2-1/8	13-1/8	5	31	13-15/16	10-5/8	14-15/16	256T	958	734
270	59-15/16	4	1-15/16	11/16	1	2-1/8	13-1/8	5	33-3/4	14-7/16	12-1/16	15-11/16	286T	1073	798
300	66-1/4	4	2-3/16	11/16	1	2-1/8	13-11/16	5	37	15-1/16	13-5/16	16-5/16	286T	1317	942
330	72-5/8	4	2-3/16	13/16	1	2-1/8	15-1/4	5	40-5/16	16-5/8	14-9/16	18	326T	1599	1132
365	80	5	2-7/16	13/16	1	2-1/8	16-3/16	6	44-3/16	17-13/16	16-1/8	19-3/8	326T	1939	1360

ALL DIMENSIONS IN INCHES. WEIGHTS IN LBS., LESS MOTOR.