

DATE: _____
 PROJECT: _____
 LOCATION: _____



Axia-Pac Wall Exhaust Fan Cast Aluminum Propeller Direct Drive

DIMENSION DATA

Size	A	B*	C	D*	Wall Opening	Wall Housing Gauge	Shipping Weight
12	19-1/2	17	14	17-3/4	17-1/4	18 GA.	88
16	23-1/2	21	18	22-1/8	21-1/4	18 GA.	110
20	27-1/2	25	22	27-1/4	25-1/4	18 GA.	156
24	33-1/2	31	27-1/2	27-1/4	31-1/4	18 GA.	220
30	39-1/2	37	33-1/2	24-1/2	37-1/4	18 GA.	273
36	45-1/2	43	39-1/2	28-1/2	43-1/4	18 GA.	393

** Correct propeller rotation is CCW when viewed from inlet side.

ALL DIMENSIONS IN INCHES. SHIP WEIGHTS IN LBS.
 * B & D DIMENSIONS ARE TO THE OUTSIDE OF FASTENERS ON WALL HOUSING.

STANDARD CONSTRUCTION FEATURES:

Cast aluminum propeller - Spun steel Venturi/wall base - Heavy duty steel power assembly - Welded wall base corners - Galvanized steel wall housing - Galvanized steel exhaust shutter - 1/2" mesh galvanized screen on inlet - Propellers are statically and dynamically balanced - Corrosion resistant fasteners.

ACCESSORIES

1. DISCONNECT SWITCH
2. MOTORIZED SHUTTER
3. EISEN-HEISS COATING
4. EPOXY COATING
5. ALUMINUM EXHAUST SHUTTER
6. ALUMINUM CONSTRUCTION
7. SPECIAL

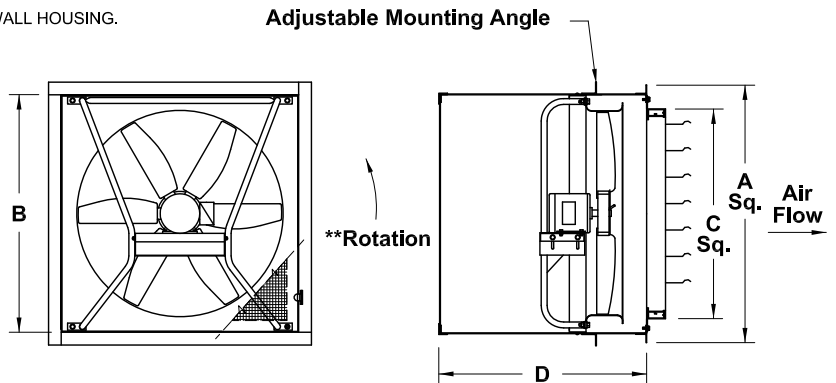

NOTE: MOUNTING ANGLE IS 2 PIECES, SHIPPED LOOSE

QTY	MARK	CATALOG NUMBER	FAN INFORMATION			MOTOR INFORMATION					ACCESSORIES							
			CFM	SP	RPM	HP	VOLTS	HZ	PH	TYPE								

MOTOR TYPE: ODP (OPEN DRIP-PROOF); **2 SP** (2 SPEED); **X-PRF** (EXPLOSION PROOF);
TEFC (TOTALLY ENCLOSED FAN COOLED).