



**COOK** X-Stream

**XLWH-Supply**

DATE: \_\_\_\_\_  
 PROJECT: \_\_\_\_\_  
 LOCATION: \_\_\_\_\_



**Heavy Duty Low-Pressure  
 Wall Supply Fan  
 Steel Propeller  
 Belt Drive**

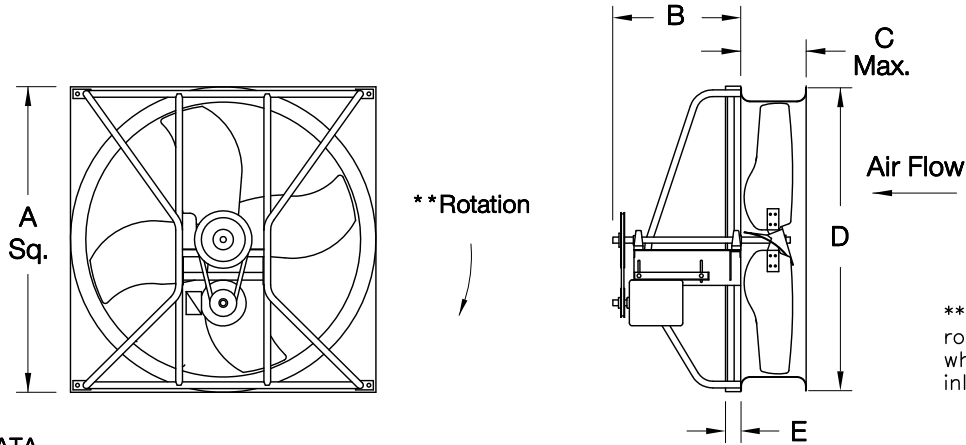

**DIMENSION DATA**

Size	A Sq.	B	C	D Dia.	E	Wall Opening*	Approx. Ship Wt.
20	24-3/16	19-1/16	6-5/8	23-3/8	2	24-7/16	136
24	30-3/16	19-1/16	6-5/8	27-3/8	3	30-7/16	146
30	36-3/16	19-1/16	6-3/4	33-3/8	3	36-7/16	171
36	42-3/16	19-1/16	7-1/4	39-3/8	3	42-7/16	208
42	48-3/16	20-11/16	8-1/16	46-3/8	3	48-7/16	272
48	54-3/16	26-5/16	8-1/16	52-3/8	3	54-7/16	344
54	60-3/16	26-5/16	9	58-3/8	3	60-7/16	419
60	66-3/16	26-5/16	9	64-3/8	3	66-7/16	462

ALL DIMENSIONS IN INCHES. WEIGHTS IN LBS., LESS MOTOR.  
 \* See wire guard or wall collar submittal for accessory wall opening.

**ACCESSORIES**

1. GALVANIZED MOTORIZED INTAKE SHUTTER
2. ALUMINUM MOTORIZED INTAKE SHUTTER
3. BAKED EPOXY POWDER
4. BAKED PHENOLIC EPOXY POWDER
5. PROP SIDE WIRE GUARD
6. MOTOR SIDE WIRE GUARD
7. WALL COLLAR
8. WEATHER HOOD
9. SHUTTER GUARD
10. DISCONNECT SWITCH
11. PRE-WIRED DISCONNECT SWITCH

**STANDARD CONSTRUCTION FEATURES:**

X-stream steel propeller – Propeller hub keyed to shaft – Propellers are statically and dynamically balanced – 14 gauge steel venturi – Welded wall base corners – Aluminum supply inlet – Heavy duty steel power assembly – Lorenized powder paint finish – Regreasable bearings in a cast housing rated at 200,000 hours average life – Adjustable pitch drives through 5 hp – Corrosion resistant fasteners – Static resistant belts – All fans factory adjusted to specified fan RPM.

QTY	MARK	CATALOG NUMBER	FAN INFORMATION			MOTOR INFORMATION					ACCESSORIES			
			CFM	SP	RPM	HP	VOLTS	HZ	PH	TYPE				

**LARGEST MOTOR SHIPPED MOUNTED: ODP (OPEN DRIP-PROOF) 5 HP; 2 SP (2 SPEED) 2 HP; X-PRF (EXPLOSION PROOF) 2 HP; TEFC (TOTALLY ENCLOSED FAN COOLED) 3 HP.**

**WP017R03**