



COOK

X-Stream

XLPH-Supply

DATE: _____

PROJECT: _____

LOCATION: _____



**Heavy Duty Low-Pressure
Wall-Pac Supply Fan
Steel Propeller
Belt Drive**

DIMENSION DATA

SIZE	A	B*	C	D*	WALL OPENING	WALL HOUSING GAUGE	SHIPPING WEIGHT
20	27-1/2	25	22	37-3/8	25-1/4	18 GA.	198
24	33-1/2	31	27-1/2	37-3/8	31-1/4	18 GA.	244
30	39-1/2	37	33-1/2	38	37-1/4	18 GA.	299
36	45-1/2	43	39-1/2	39-1/2	43-1/4	18 GA.	367
42	51-1/2	49-1/16	45-1/2	41	49-1/4	16 GA.	487
48	57-1/2	55-1/16	51-1/2	51	55-1/4	16 GA.	603
54	63-1/2	61-1/8	57-1/2	48	61-1/2	14 GA.	728
60	69-1/2	67-1/8	63-1/2	48	67-1/2	14 GA.	803

ALL DIMENSIONS IN INCHES. WEIGHTS IN LBS., LESS MOTOR.

* B & D DIMENSIONS ARE TO OUTSIDE OF FASTENERS ON WALL HOUSING.

STANDARD CONSTRUCTION FEATURES:

X-stream steel propeller – Propeller hub keyed to shaft – Continuously welded wall panel corners – Galvanized steel wall housing – Adjustable mounting angle – Galvanized steel wire guard – Motorized supply shutter – Heavy duty tubular steel power assembly – Lorenized powder paint finish on non galvanized steel parts – Corrosion resistant fasteners – 14 gauge steel venturi – Permanently lubricated ball bearing motor – Regreasable bearings in a cast housing rated at 200,000 hours average life – Adjustable pitch drives through 5 hp motor – All fans factory adjusted to specified RPM.

NOTE: Mounting angle is 2 pieces, shipped loose.

ACCESSORIES

1. DISCONNECT SWITCH
2. WEATHER HOOD
3. SHUTTER GUARD
4. ALUMINUM HOUSING
5. SPECIAL

Note: Correct propeller rotation is CCW when viewing from inlet side.

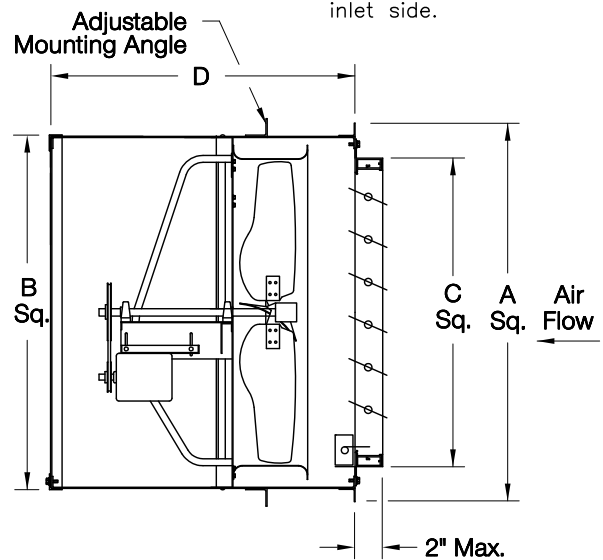

QTY	MARK	CATALOG NUMBER	FAN INFORMATION			MOTOR INFORMATION					ACCESSORIES							
			CFM	SP	RPM	HP	VOLTS	HZ	PH	TYPE								

LARGEST MOTOR SHIPPED MOUNTED: ODP (OPEN DRIP-PROOF) 5 HP; 2 SP (2 SPEED) 3 HP; X-PRF (EXPLOSION PROOF) 3 HP; TEFC (TOTALLY ENCLOSED FAN COOLED) 5 HP.

WP025R03