

DATE: _____
 PROJECT: _____
 LOCATION: _____

**Extruded Aluminum Propeller
 Wall-Pac Exhaust Fan
 Belt Drive**



DIMENSION DATA

Size	A	B*	C	D*	Wall Opening	Wall Housing Gauge	Shipping Weight
24	39-1/2	37	33-1/2	38	37-1/4	18 GA.	297
30	45-1/2	43	39-1/2	39-1/2	43-1/4	18 GA.	367
36	51-1/2	49-1/16	45-1/2	41	49-1/4	16 GA.	453
42	57-1/2	55-1/16	51-1/2	51	55-1/4	16 GA.	564
48	63-1/2	61-1/8	57-1/2	48	61-3/8	14 GA.	698
54	69-1/2	67-1/8	63-1/2	48	67-3/8	14 GA.	782
60	75-1/2	73-1/8	69-1/2	48	73-3/8	14 GA.	880
72	87-1/2	85-1/8	81-1/2	51	85-3/8	14 GA.	1090

Note: Correct propeller rotation is CCW (size 72 is CW) when viewing

ALL DIMENSIONS IN INCHES. SHIP WEIGHTS IN LBS., LESS MOTOR.
 * B & D DIMENSIONS ARE TO OUTSIDE OF FASTENERS ON WALL HOUSING.

STANDARD CONSTRUCTION FEATURES:

Extruded aluminum propeller- Propeller hub keyed to shaft - Continuously welded wall panel corners - Galvanized steel wall housing - Adjustable mounting angle - Galvanized steel wire guard - Galvanized exhaust shutter - Heavy duty tubular steel power assembly - Lorenized powder paint finish on all uncoated steel parts - Corrosion resistant fasteners - 14 gauge steel venturi - Aluminum supply inlet - Permanently lubricated ball bearing motor - Regreasable bearings in a cast housing rated at 200,000 hours average life - Adjustable pitch drives through 5 hp motor - Static resistant belts - All fans factory adjusted to specified RPM.

NOTE: Mounting angle is 2 pieces, shipped loose.

ACCESSORIES

1. DISCONNECT SWITCH
2. STD DUTY ALUMINUM EXHAUST SHUTTER
3. HVY DUTY ALUMINUM EXHAUST SHUTTER
4. MOTORIZED EXHAUST SHUTTER
5. WEATHER HOOD
6. SHUTTER GUARD
7. ALUMINUM HOUSING

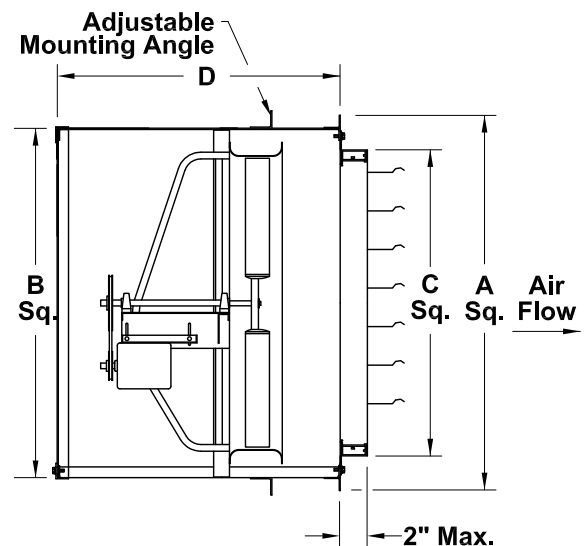

QTY	MARK	CATALOG NUMBER	FAN INFORMATION			MOTOR INFORMATION					ACCESSORIES						
			CFM	SP	RPM	HP	VOLTS	HZ	PH	TYPE							

LARGEST MOTOR SHIPPED MOUNTED: ODP (OPEN DRIP-PROOF) 5 HP; 2 SP (2 SPEED) 2 HP; X-PRF (EXPLOSION PROOF) 2 HP; TEFC (TOTALLY ENCLOSED FAN COOLED) 3 HP.