

DATE: _____

PROJECT: _____

LOCATION: _____

**Extruded Aluminum Propeller
 Wall-Pac Exhaust Fan
 Direct Drive**

DIMENSION DATA

Size	A	B*	C	D*	Wall Opening	Wall Housing Gauge	Shipping Weight
24	39-1/2	37	33-1/2	24-1/2	37-1/4	18 GA.	282
30	45-1/2	43	39-1/2	28-1/2	43-1/4	18 GA.	346
36	51-1/2	49-1/16	45-1/2	34	49-1/4	18 GA.	457
42	57-1/2	55-1/16	51-1/2	40	55-1/4	18 GA.	598
48	63-1/2	61-1/8	57-1/2	40-1/2	61-3/8	18 GA.	699
54	69-1/2	67-1/8	63-1/2	45	67-3/8	18 GA.	810

Note: Correct propeller rotation is CCW when viewing from inlet side.

ALL DIMENSIONS IN INCHES. SHIP WEIGHTS IN LBS., LESS MOTOR.
 *B&D DIMENSIONS ARE TO OUTSIDE OF FASTENERS ON WALL HOUSING.

STANDARD CONSTRUCTION FEATURES:

Extruded Aluminum propeller - Propeller hub keyed to shaft - Continuously welded wall panel corners - Galvanized steel wall housing - Adjustable mounting angle - Galvanized steel wire guard - Galvanized exhaust shutter - Heavy duty tubular steel power assembly - Lorenized powder paint finish - Corrosion resistant fasteners - 14 gauge steel venturi - Aluminum supply inlet - Permanently lubrication ball bearing motor.

NOTE: Mounting angle is 2 pieces, shipped loose.

ACCESSORIES

1. DISCONNECT SWITCH
2. STD DUTY ALUMINUM EXHAUST SHUTTER
3. HVY DUTY ALUMINUM EXHAUST SHUTTER
4. MOTORIZED EXHAUST SHUTTER
5. WEATHER HOOD
6. SHUTTER GUARD
7. ALUMINUM HOUSING
8. SPECIAL

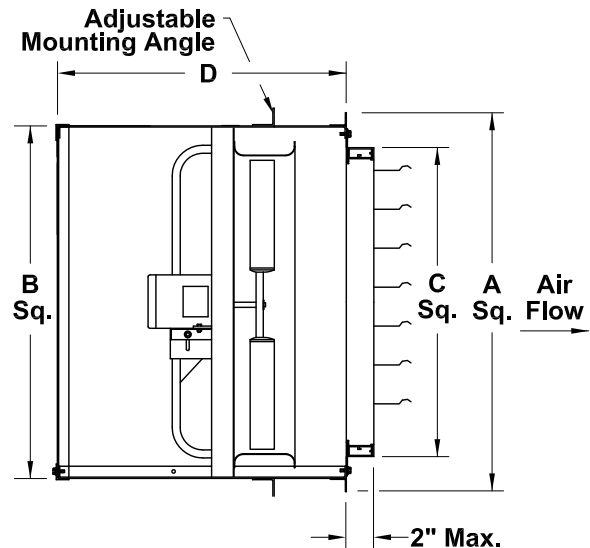

QTY	MARK	CATALOG NUMBER	FAN INFORMATION			MOTOR INFORMATION					ACCESSORIES										
			CFM	SP	RPM	HP	VOLTS	HZ	PH	TYPE											

LARGEST MOTOR SHIPPED MOUNTED: ODP (OPEN DRIP-PROOF) 5 HP; 2 SP (2 SPEED) 3 HP; X-PRF (EXPLOSION PROOF) 3 HP; TEFC (TOTALLY ENCLOSED FAN COOLED) 5 HP.