



COOK

Shutter

DATE: _____

PROJECT: _____

LOCATION: _____

Discharge
Aluminum Construction
EWB
Propeller Fans

DIMENSION DATA

Model No.		Unit Size EWB and EWB w/ Wall Collar	A Sq.	B Sq.	Max. CFM for Standard Duty	Number of Panels		Ship. Wt.	
Standard Duty	Heavy Duty					Std Duty	Heavy Duty	Std Duty	Heavy Duty
GSS-33	GSH-33	24	36	33	15125	1	1	11	17
GSS-39	GSH-39	30	42	39	21125	1	1	16	23
GSS-45	GSH-45	36	48	45	28125	1	1	21	31
-	GSH-51	42	54	51	-	-	2	-	39
-	GSH-57	48	60	57	-	-	2	-	49
-	GSH-63	54	66	63	-	-	2	-	60
-	GSH-69	60	72	69	-	-	2	-	72
-	GSH-81	72	84	81	-	-	2	-	106

ALL DIMENSIONS IN INCHES. WEIGHTS IN LBS.

THE MODEL GSS AND GSH SHUTTERS ARE DESIGNED TO REDUCE BACK DRAFTS; PREVENT ENTRY OF SOME FOREIGN MATERIAL AND PESTS, SUCH AS BIRDS; AND LIMIT THE AMOUNT OF RAIN THAT ENTERS THE BUILDING. THESE SHUTTERS ARE INTENDED TO BE WEATHER-RESISTANT, BUT ARE NOT WEATHER-PROOF FOR EXTREME CONDITIONS.

STANDARD CONSTRUCTION FEATURES:

Blades are roll formed 5052 aluminum (Std.) or extruded 6063 T6 aluminum (Hvy.). Blades have vinyl edge gasket. Damper frame is extruded 6063 T6 aluminum. Extruded aluminum blade link bar connects each blade for uniform blade positioning. Blades pivot on full width extruded aluminum blade hanger for added strength.

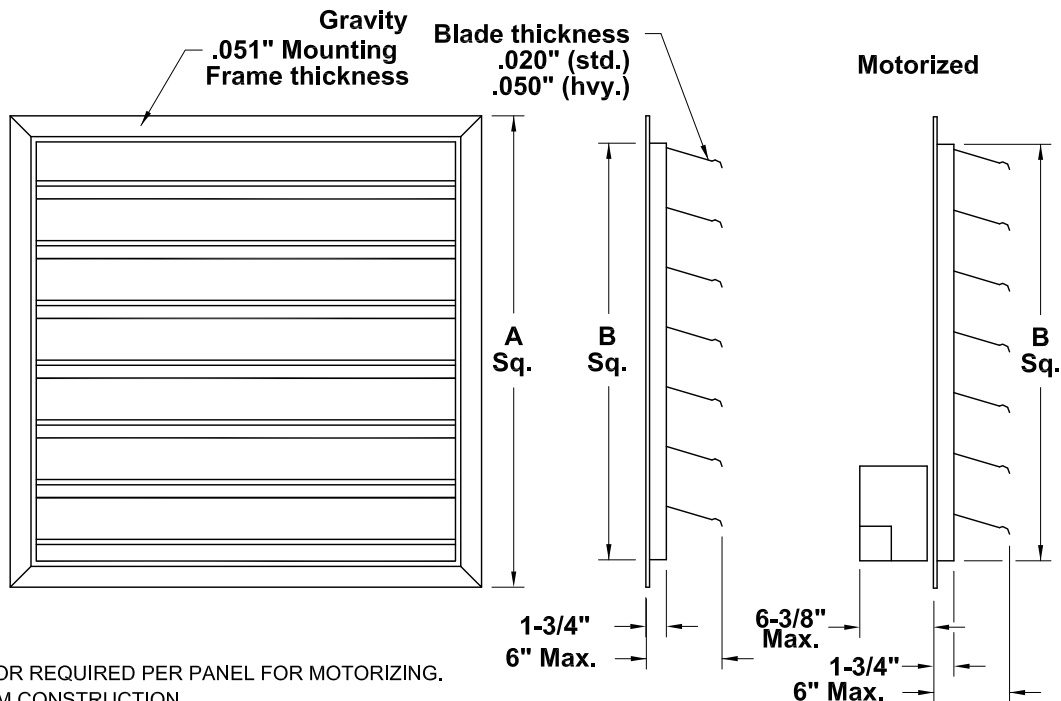

NOTES:

- 1) ONE ACTUATOR REQUIRED PER PANEL FOR MOTORIZING.
- 2) ALL ALUMINUM CONSTRUCTION.
- 3) TO ORDER A MOTORIZED SHUTTER, SUBSTITUTE "M" FOR "G" IN MODEL NO.
- 4) ADD 2# TO SHIPPING WT FOR EACH MOTOR ON MOTORIZED UNITS.
- 5) USE STANDARD DUTY SHUTTER FOR DISCHARGE VELOCITIES OF 0-2000 FPM. MOTOR OPERATED DAMPERS REQUIRED FOR VELOCITIES BELOW 400 FPM. USE HEAVY DUTY SHUTTERS FOR VELOCITIES 2000-3000 FPM.

X0222R08