

This publication contains the installation, operation and maintenance instructions for standard units of the *Gemini: Ceiling and Cabinet Fans*.



Carefully read this publication and any supplemental documents prior to any installation or maintenance procedure.

Loren Cook catalog, *Gemini*, provides additional information describing the equipment, fan performance, available accessories and specification data.

For additional safety information, refer to AMCA Publication 410-96, *Safety Practices for Users and Installers of Industrial and Commercial Fans*.

All of the publications listed above can be obtained from:

- lorencook.com
- info@lorencook.com
- 417-869-6474 ext. 166

For information and instructions on special equipment, contact Loren Cook Company at 417-869-6474.

Receiving and Inspection

Carefully inspect the fan and accessories for any damage and shortage immediately upon receipt of fan.

- Turn the wheel by hand to ensure it turns freely and does not bind.
- Inspect dampers (if included) for free operation of all moving parts.
- Remove mounting brackets from packing insert.
- Install mounting brackets as shown in *Figure 4*.
- Remove shipping tape.
- Record on the *Delivery Receipt* any visible sign of damage.

Handling

Lift fan by grasping the outside housing (cabinet) or blower mounting brace. Never lift by the shaft or motor.

Storage

If the fan is stored for any length of time prior to installation, store it in its original shipping crate to protect it from dust, debris and the weather.

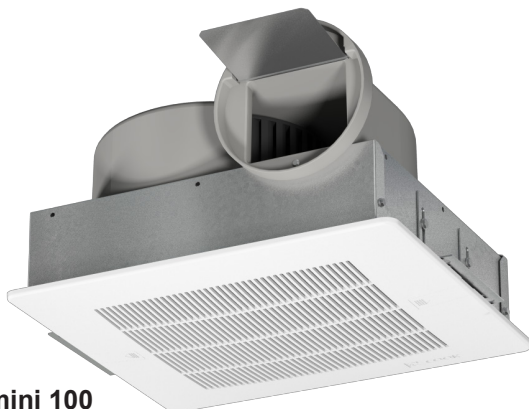

Gemini 100

!WARNING

Rotating Parts & Electrical Shock Hazard:

Fans should be installed and serviced by qualified personnel only.

Disconnect electric power before working on unit (prior to removal of guards or entry into access doors).

Follow proper lockout/tagout procedures to ensure the unit cannot be energized while being installed or serviced.

A disconnect switch should be placed near the fan, so power can be swiftly turned off in case of an emergency. This will also allow maintenance personnel to have complete control of the power source.

Grounding is required. All field-installed wiring must be completed by qualified personnel. All field installed wiring must comply with National Electric Code (NFPA 70) and all applicable local codes.

Fans and blowers create pressure at the discharge and vacuum at the inlet. This may cause objects to get pulled into the unit and objects to be propelled rapidly from the discharge. The discharge should always be directed in a safe direction and inlets should not be left unguarded. Any object pulled into the inlet will become a projectile capable of causing serious injury or death.

When air is allowed to move through a non-powered fan, the impeller can rotate. This is referred to as windmilling. This unexpected rotation of components can cause a hazardous condition. Impellers should be blocked in position or air passages blocked to prevent draft prior to working on fans.

Friction and power loss inside rotating components can cause them to be a potential burn hazard. All components should be approached with caution and/or allowed to cool before contacting them for maintenance.

Under certain lighting conditions, rotating components may appear stationary. Components should be verified to be stationary in a safe manner, before they come into contact with personnel, tools or clothing.

Failure to follow these instructions could result in death or serious injury.

⚠ CAUTION

For general ventilation use only. Do not use to exhaust hazardous vapors or explosive materials.

Installation

Motor Installation

All Gemini units are shipped with motors mounted at the factory.

Do not install above or inside shaded area

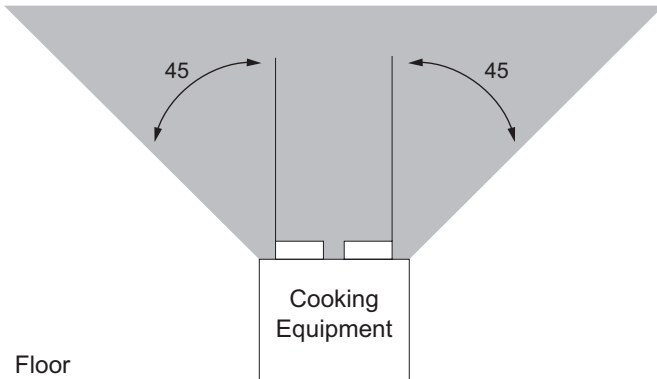

Fan Installation

1. Fasten duct work to the outside of the duct collar (damper frame) using sheet metal screws. Make sure sheet metal screws are placed where they do not interfere with damper operation. Do not mount near cooking equipment (see above).
2. Fasten the housing to the bottom of the joists through the holes provided in the mounting bracket. Refer to *Figure 1*.
3. Adjust housing using the mounting bracket provided. To allow for the thickness of finished ceiling and grille, refer to *Figure 2*. If a unit is furnished with filters, allow 3/8". Refer to *Figure 3*.

Ceiling Radiation Damper Installation (See Gemini/CRD Installation Supplement)

Wiring Installation

All wiring should be in accordance with local ordinances and the National Electrical Code, NFPA 70. Ensure the power supply (voltage, frequency, and current carrying capacity of wires) is in accordance with the motor nameplate. Refer to *Wiring Diagrams*, page 4.

- a. **Lock off all power sources before unit is wired to power source.**
- b. **Follow the wiring diagram in the disconnect switch and the wiring diagram provided with the motor.**
- c. **Correctly label the circuit on the main power box and always identify a closed switch to promote safety (i.e., red tape over a closed switch).**

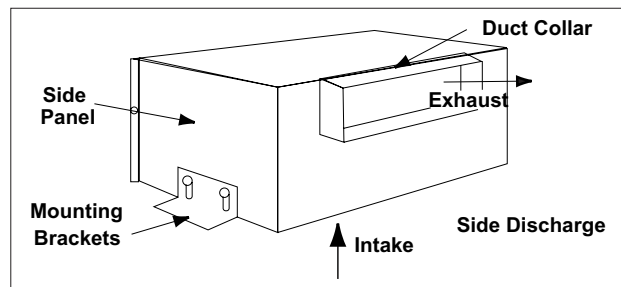

Figure 1

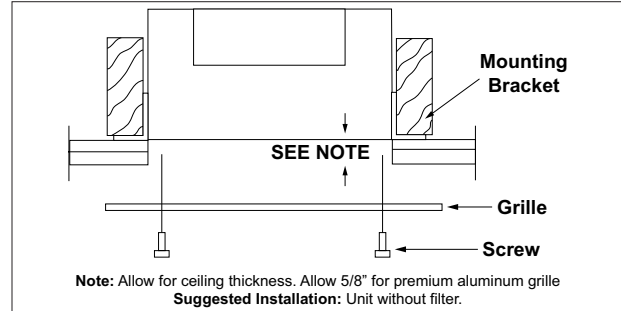

Figure 2

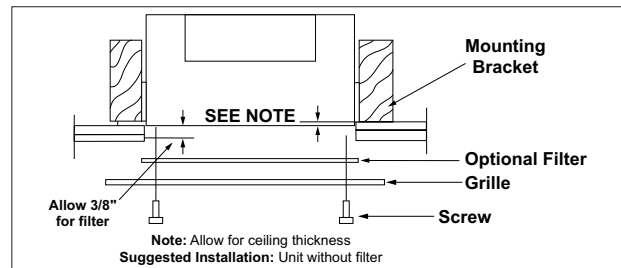

Figure 3

Final Installation Steps

1. Inspect fasteners and setscrews, particularly fan mounting fasteners, and tighten according to the recommended torque shown in the table, Recommended Torque for Setscrews/Bolts.
2. Inspect for correct amperage and voltage with an ammeter and voltmeter.
3. Ensure blower is secured to duct work.
4. Ensure all accessories are installed.
5. Inspect wheel-to-inlet clearance. Make sure wheel does not rub against the inlet.
6. Test the fan to be sure the rotation is the same as indicated by the arrow marked Rotation.

Operation

Pre-Start Checks:

1. Lock out all the primary and secondary power sources.
2. Inspect fasteners and setscrews, particularly those used for mounting the fan, and tighten if necessary.
3. Inspect motor wiring.
4. Ensure fan and duct work are clean and free of debris.
5. Test the fan to ensure the rotation of the wheel is the same as indicated by the rotation label.
6. Restore power to unit.

Start Up

Before attaching the grille, turn the fan on and inspect for the following:

- Direction of rotation.
- Excessive vibration.
- Unusual noise.
- Motor noise.
- Improper motor amperage or voltage. If a problem is discovered, immediately shut off the fan. Lock out all electrical power and check for the cause of the problem. Refer to *Troubleshooting*, page 3.

Inspection

Inspection of the fan should be conducted at the first 30 minute interval of satisfactory operation. During the inspection, stop the fan and inspect as per directions below.

30 Minute Interval

Inspect bolts, setscrews, and motor mounting bolts. Adjust and tighten as necessary.

Grille Installation

Attach grille to housing using the packaged screws provided with optional filter, align holes in filter frame with holes in grille and mount to housing using the same screws provided.

Maintenance

Establish a schedule for inspecting all parts of the fan. The frequency of inspection depends on the operating conditions and location of the fan.

Fans exhausting contaminated air (airborne abrasives) should be inspected every three months.

Under normal conditions, it is recommended to conduct the following inspections twice a year:

- Inspect bolts and setscrews for tightness. Tighten as necessary.
- Inspect for cleanliness. Clean exterior surfaces only. Removing dust and grease on motor housing assures proper motor cooling.

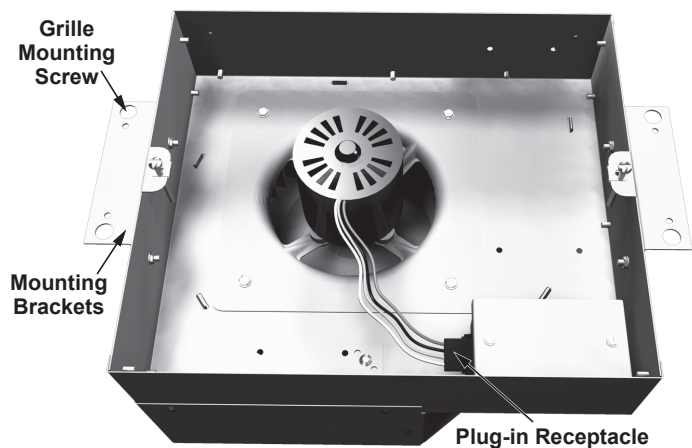

Figure 4 - Gemini 100 Series Components

Access

To inspect, clean or repair refer to *Figure 4* and follow these steps:

1. Remove grille.
2. Remove blower assembly from housing:
 - a. Disconnect the motor from electrical supply.
 - b. Remove the mounting bolts on the inlet plate assembly and remove the motor/wheel assembly.
3. Remove the blower wheel with an allen wrench.

Motor Bearings

Motor bearings are pre-lubricated and sealed. Under normal conditions they will not require further maintenance for a period of ten years.

Motor Services

Should the motor prove defective within a one-year period, contact your local Loren Cook representative or your nearest authorized electric motor service representative.

Troubleshooting

Problem and Potential Cause

Low Capacity or Pressure:

- Incorrect direction of rotation. Make sure the fan rotates in same direction as the arrows on the motor or belt drive assembly.
- Poor fan inlet conditions. There should be a straight clear duct at the inlet.
- Improper wheel alignment.
- Damper held shut by tape.
- Screw attaching duct work to collar interfering with damper operation.

Excessive Vibration and Noise:

- Damaged or unbalanced wheel.
- Speed too high.
- Incorrect direction of rotation. Make sure the fan rotates in same direction as the arrows on the motor or belt drive assembly.
- Motor needs lubrication or replacement.
- Fan surge.

Overheated Motor:

- Motor improperly wired.
- Incorrect direction of rotation. Make sure the fan rotates in same direction as the arrows on the motor or belt drive assembly.
- Cooling air diverted or blocked.
- Improper inlet clearance.
- Incorrect fan RPMs.
- Incorrect voltage.

Wiring Diagrams

Gemini 100 Series

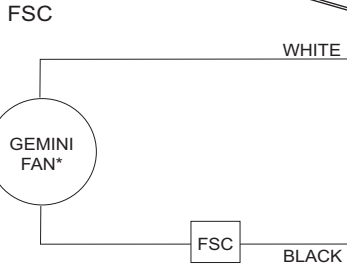
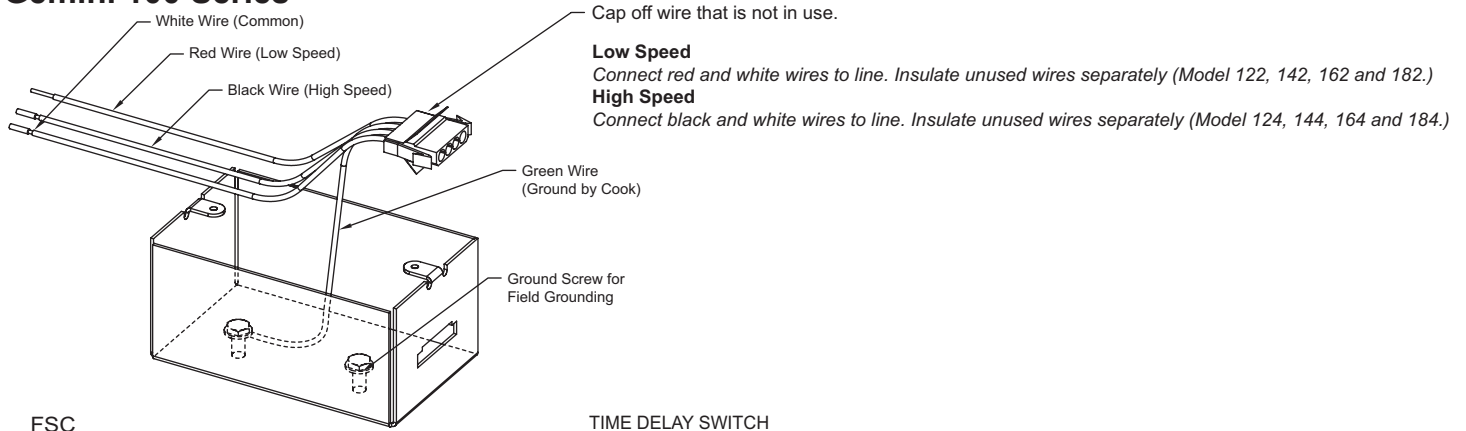

*See Gemini Wiring Diagram for correct lead.

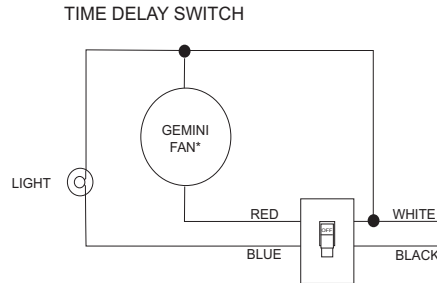

*See Gemini Wiring Diagram for correct lead.

Gemini 100 Parts List

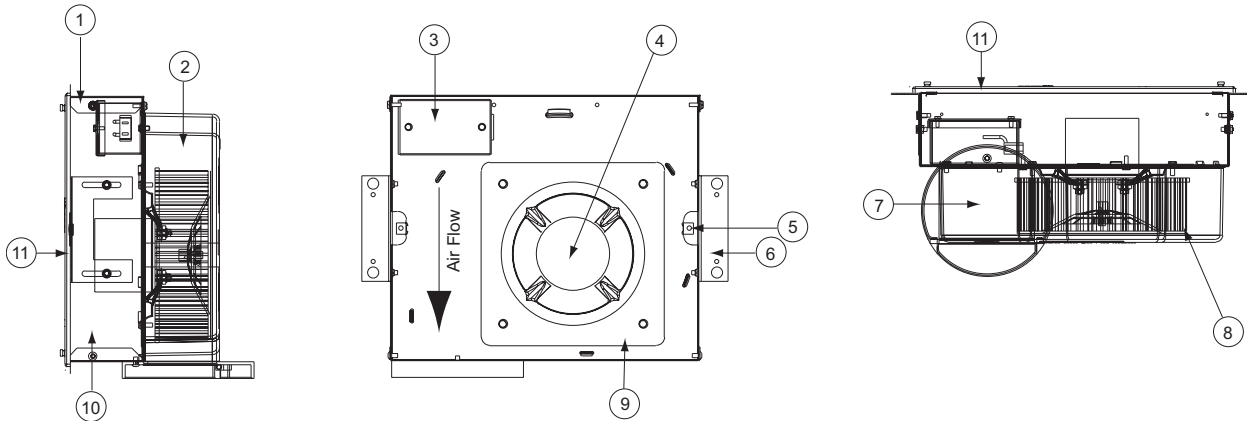

Part No.	Gemini 100	
1	Inlet Box End Plate (Ceiling only)	7 Backdraft Damper
2	Housing/Scroll	8 Wheel
3	Field Wiring Compartment	9 Motor Mount/Inlet
4	Motor	10 Inlet Box
5	Tinnerman Clip (Grille)	11 Grille
6	Mounting Bracket	

Limited Warranty

Loren Cook Company warrants that your Loren Cook fan was manufactured free of defects in materials and workmanship, to the extent stated herein. For a period of one (1) year after date of shipment, we will replace any parts found to be defective without charge, except for shipping costs which will be paid by you. This warranty is granted only to the original purchaser placing the fan in service. This warranty is void if the fan or any part thereof has been altered or modified from its original design or has been abused, misused, damaged or is in worn condition or if the fan has been used other than for the uses described in the company manual. This warranty does not cover defects resulting from normal wear and tear. To make a warranty claim, notify Loren Cook Company, General Offices, 2015 East Dale Street, Springfield, Missouri 65803-4637, explaining in writing, in detail, your complaint and referring to the specific model and serial numbers of your fan. Upon receipt by Loren Cook Company of your written complaint, you will be notified, within thirty (30) days of our receipt of your complaint, in writing, as to the manner in which your claim will be handled. If you are entitled to warranty relief, a warranty adjustment will be completed within sixty (60) business days of the receipt of your written complaint by Loren Cook Company. This warranty gives only the original purchaser placing the fan in service specifically the right. You may have other legal rights which vary from state to state.

LOREN COOK COMPANY

Corporate Offices: 2015 E. Dale St. Springfield, MO 65803
Phone 417-869-6474 | Fax 417-862-3820 | lorencook.com