



COOK

TDB

DATE: _____

PROJECT: _____

LOCATION: _____



**Twin Duct Blower
Internal Belt Drive**

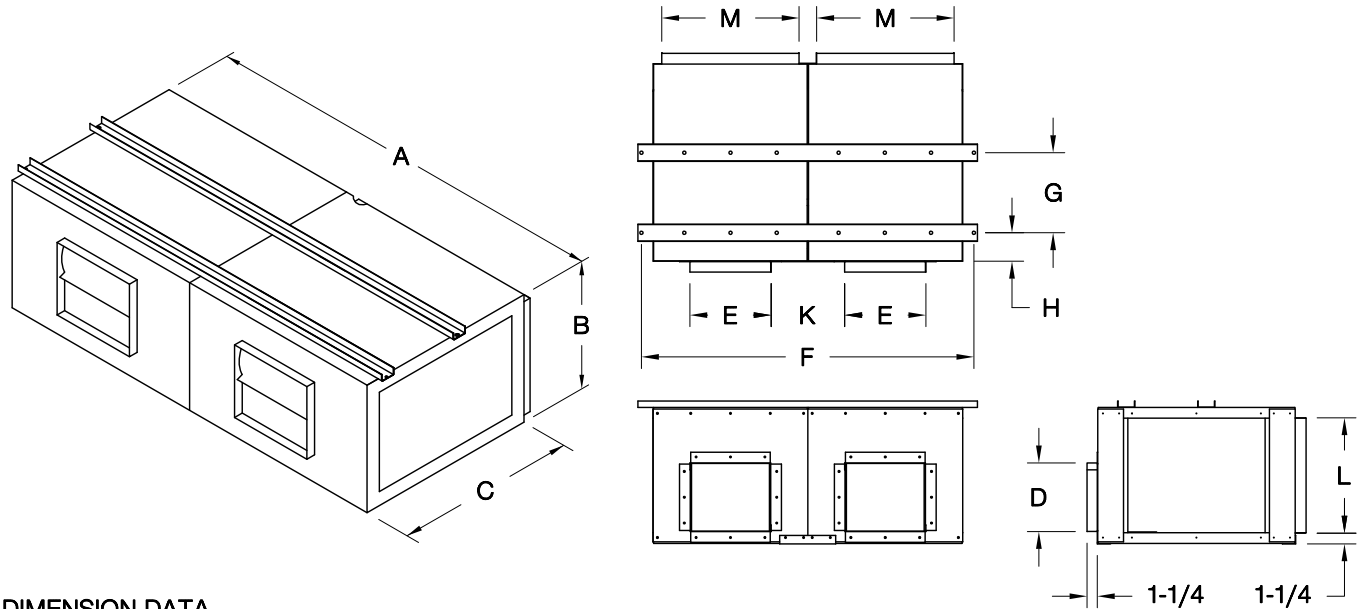

DIMENSION DATA

Size	A	B	C	D O.D.	E O.D.	F	G	H	K	L O.D.	M O.D.	Max H.P.	Ship Wt.
TDB-8	36-5/8	15-7/16	23	7-7/8	9-1/4	38	9-5/8	2-1/8	9-1/4	13-7/16	16-1/8	1	135
TDB-9	42-5/8	18-1/8	25-3/4	10-5/16	11-7/8	44	11-3/4	2-1/2	9-5/8	16-1/8	19-1/8	2	175
TDB-10	45-1/8	20-1/8	28-1/4	11-3/8	13-1/8	46-1/2	13-3/8	2-1/2	9-5/8	18-1/8	20-3/8	2	225
TDB-13	54-5/8	23-3/16	31-1/4	13-7/16	15-5/8	56	16-1/8	2-1/2	11-7/8	21-3/16	25-1/8	3	350
TDB-15	65-3/8	26-15/16	36-1/4	15-7/8	18-5/8	66-3/4	19-1/2	2-1/2	14-1/4	24-15/16	30-1/2	5	425
TDB-18	82-3/8	31-7/8	44-3/4	18-7/8	21-7/8	83-3/4	24	2-11/16	19-1/2	29-7/8	39	7-1/2	750

ALL DIMENSIONS IN INCHES. WEIGHTS IN LBS.

STANDARD CONSTRUCTION FEATURES:

Galvanized steel housing – Permanently lubricated ball bearing motors – Blower is vibration isolated from the housing – Static resistant belts – Bearings rated at 200,000 hours average life – Adjustable pitch drives through 5 hp motor – Corrosion resistant fasteners – Removable side access panel – Horizontal hanging brackets – All fans factory adjusted to specified fan RPM.

ACCESSORIES

1. SLIDE-OUT FILTER BOX
2. NEMA 1 DISCONNECT SWITCH
3. AUTO BACKDRAFT DAMPER

QTY	MARK	CATALOG NUMBER	FAN INFORMATION			MOTOR INFORMATION					ACCESSORIES							
			CFM	SP	RPM	HP	VOLTS	HZ	PH	TYPE								

LARGEST MOTOR SHIPPED MOUNTED: ODP (OPEN DRIP-PROOF) 2 HP; 2 SP (2 SPEED) 1 HP; X-PRF (EXPLOSION PROOF) 1 HP; TEFC (TOTALLY ENCLOSED FAN COOLED) 1 HP.

U.L. LISTING ONLY AVAILABLE WITH TEFC MOTOR.

DB004R06